

205206-9 ✓ ACTIVE

AMPLIMITE

TE Internal #: 205206-9

Plug, Cable-to-Cable, 15 Position, Size 20 Contact Size, 2
Connector Shell Size, Mating Retention, Shielded, Crimp D-Sub
Connectors

[View on TE.com >](#)



Connectors > D-Shaped Connectors > D-Sub Connectors > Crimp D-Sub Connectors > D-Sub Crimp: Plug, Signal, 15 Posn, Pin Size 20, Shell Size 2



Connector & Housing Type: **Plug**

Connector System: **Cable-to-Cable**

Number of Positions: **15**

Contact Size: **Size 20**

Connector Shell Size: **2**

[All D-Sub Crimp: Plug, Signal, 15 Posn, Pin Size 20, Shell Size 2 \(10\)](#)

Features

Product Type Features

Shell Material Configuration	Full Metal Shell
Connector & Contact Terminates To	Wire & Cable
Connector & Housing Type	Plug
Connector System	Cable-to-Cable
Connector Shell Size	2
Sealable	No

Configuration Features

Number of Positions	15
---------------------	----

Body Features

Insert Material	Thermoplastic
Shield Material	Steel
Shell Plating Material	Zinc



Contact Features

Contact Options	Order Separately
Contact Size	Size 20

Termination Features

Termination Method to Wire & Cable	Crimp
------------------------------------	-------

Mechanical Attachment

Mating Retention	With
Mating Retention Type	Mounting Holes

Housing Features

Shell Material	Steel
Centerline (Pitch)	2.74 mm [.108 in]

Usage Conditions

Operating Temperature Range	-55 – 105 °C [-67 – 221 °F]
-----------------------------	-----------------------------

Operation/Application

Circuit Application	Signal
Shielded	Yes

Industry Standards

UL Flammability Rating	UL 94V-0
------------------------	----------

Packaging Features

Packaging Quantity	400
Packaging Method	Package

Product Compliance

[For compliance documentation, visit the product page on TE.com>](#)

EU RoHS Directive 2011/65/EU	Compliant
EU ELV Directive 2000/53/EC	Compliant
China RoHS 2 Directive MIIT Order No 32, 2016	No Restricted Materials Above Threshold
EU REACH Regulation (EC) No. 1907/2006	Current ECHA Candidate List: JUNE 2024 (241) Candidate List Declared Against: JUNE 2024 (241) Does not contain REACH SVHC
Halogen Content	Not Low Halogen - contains Br or Cl > 900 ppm.



Solder Process Capability

Not applicable for solder process capability

Product Compliance Disclaimer

This information is provided based on reasonable inquiry of our suppliers and represents our current actual knowledge based on the information they provided. This information is subject to change. The part numbers that TE has identified as EU RoHS compliant have a maximum concentration of 0.1% by weight in homogenous materials for lead, hexavalent chromium, mercury, PBB, PBDE, DBP, BBP, DEHP, DIBP, and 0.01% for cadmium, or qualify for an exemption to these limits as defined in the Annexes of Directive 2011/65/EU (RoHS2). Finished electrical and electronic equipment products will be CE marked as required by Directive 2011/65/EU. Components may not be CE marked. Additionally, the part numbers that TE has identified as EU ELV compliant have a maximum concentration of 0.1% by weight in homogenous materials for lead, hexavalent chromium, and mercury, and 0.01% for cadmium, or qualify for an exemption to these limits as defined in the Annexes of Directive 2000/53/EC (ELV). Regarding the REACH Regulation, the information TE provides on SVHC in articles for this part number is based on the latest European Chemicals Agency (ECHA) 'Guidance on requirements for substances in articles' posted at this URL: <https://echa.europa.eu/guidance-documents/guidance-on-reach>

Compatible Parts



TE Part # CAT-035-DCPPS202
D-Sub Crimp: Plug, Signal, 15 Posn, Pin Size 20, Shell Size 2



TE Part # CAT-035-DCRSS202
D-Sub Crimp Rcpt Signal 15 Posn, Socket Size 20, Shell Size 2



TE Part # 5206471-1
CABLE CLAMP KIT, SZ 2



TE Part # 745229-1
20 DF CONT. CRMPTYPE

Customers Also Bought



TE Part # 5745036-2
PLUG ASSY, 25P, HDP-20, CN



TE Part # 205210-8
PLUG ASSY SIZE 4



TE Part # 1658641-3
PLUG ASSY SIZE 5



TE Part # 205209-7
RECP ASSY SIZE 4



TE Part # 5205207-1
HD RECP ASSY SIZE 3



TE Part # 205203-8
CRIMP SNAP RCPT ASSY, SIZE 1



TE Part # 2273005-2
M8 x 1.0 straight socket Pigtail Shld



TE Part # 5205730-1
CLAMSHELL ASY SIZE 2

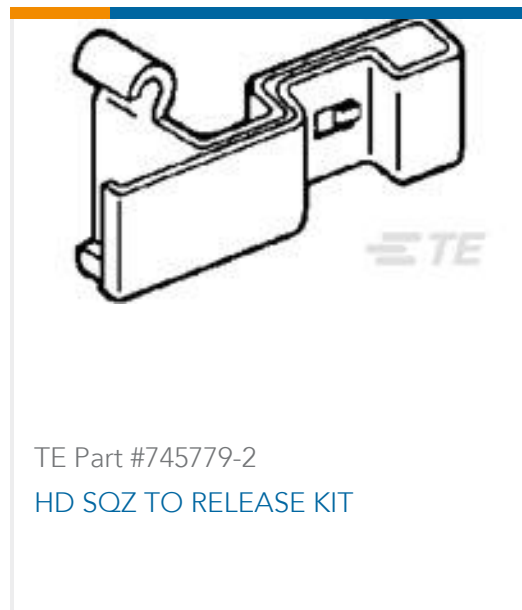

Documents

Product Drawings

CRIMP SNAP PLUG ASSY,SIZE 2

English

CAD Files

3D PDF

3D

Customer View Model

[ENG_CVM_CVM_205206-9_W.2d_dxf.zip](#)

English

Customer View Model

[ENG_CVM_CVM_205206-9_W.3d_igs.zip](#)

English

Customer View Model

[ENG_CVM_CVM_205206-9_W.3d_stp.zip](#)

English

By downloading the CAD file I accept and agree to the [Terms and Conditions](#) of use.

Datasheets & Catalog Pages

AMPLIMITE Subminiature D Connectors - Cable Connectors

English

AMPLIMITE Cable Connectors and Shielding Hardware Kits QRG

English

Product Specifications

Application Specification

English

Instruction Sheets

Instruction Sheet (U.S.)

English

Agency Approvals

CSA Certificate

English