

- 注記 NOTES**
- 偶数極品に適用。
APPLIES ONLY TO EVEN NO. CKT. SIZES.
 - 嵌合相手: 51102, 51103 シリーズ
MATES WITH: 51102, 51103 SERIES.
 - 累積ピッチの許容差は、20ピッチで ± 1.0 mm とする。
ACCUMULATED TOLERANCE IS TO BE ± 1.0 mm PER 20 PITCH.
 - 粘着テープは台紙からはみ出さないこと。
THE ADHESIVE TAPE SHOULD NOT BE PROTRUDED FROM THE BASE TAPE.
 - リード線の曲がりの許容差は 1mm MAX. とする。
CAMBER OF THE LEADS: 1mm MAX.
 - 測定位置は、コネクタの先端とする。
INCLINED POSITION FROM THE CENTER-LINE, SHOULD BE 1mm MAX. MEASURING SHOULD BE DONE, USING THE TOP OF BASE TAPE AS DATUM.
 - 測定位置は、台紙の上端とし、リード線の中心線との間隔とする。
DIM. 3.85 AND DIM. 5 SHOULD BE MEASURED ON THE TOP OF BASE TAPE. DIMENSIONS ARE A SPACING BETWEEN THE CENTER-LINES.

400	9.95	25.4	22.4	20.7	17.5	53375-0890	8
	7.45	↑	19.9	18.2	15	↑	-0790
500	7.45	↓	17.4	15.7	12.5	↓	-0690
	4.95	↓	14.9	13.2	10	↓	-0590
900	4.95	↓	12.4	10.7	7.5	↓	-0490
	2.45	↓	9.9	8.2	5	↓	-0390
	2.45	↓	7.4	5.7	2.5	↓	-0290
包装数量/箱 QTY./CARTON	E	D	C	B	A	MATERIAL NO.	極数 NO. OF CKTS.

材料 MATERIAL		図中参照 SEE DRAWING		molex MOLEX-JAPAN CO., LTD. 日本モレックス株式会社			
E	変更 REVISED (J2004-3573)	Y.W.	M.S.	04/04/05	仕上げ FINISH —		
D	変更 REVISED (J30223)	K.T.	H.H.	'93/3/10			
C	変更 REVISED (J3021)	K.T.	H.H.	'93/2/9	適用電線範囲 WIRE RANGE —		
B	変更 REVISED (J30000)	H.H.	M.F.	'93/1/7	被覆外径 INS. RANGE —		
A	変更 REVISED (J20671)	K.T.	H.H.	'92/7/29	DRAWN BY '92/5/6 K.TOJO		
①	新規作成 PROPOSED (J20390)	K.T.	H.H.	'92/5/8		CHK'D BY '93/3/10 H.HIRAMOTO	
一般公差 GENERAL TOLERANCES		記号 LTR	変更内容 REVISION RECORD	日付 DATE	尺度 SCALE 3:1	DWG. NO. (SHEET 1 OF 2) SD-53375-***90	REV E

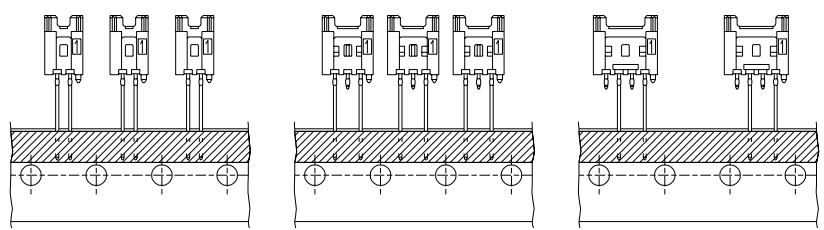

(2 極) (2 CKT.) (3 極) (3 CKT.) (4 極) (4 CKT.)

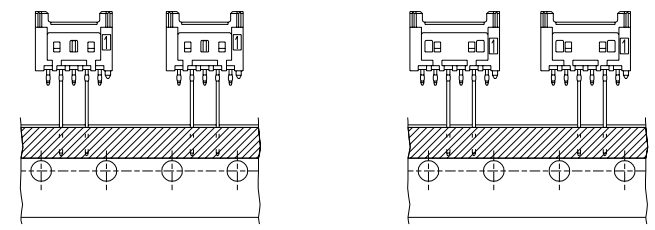

(5 極) (5 CKT.) (6 極) (6 CKT.)

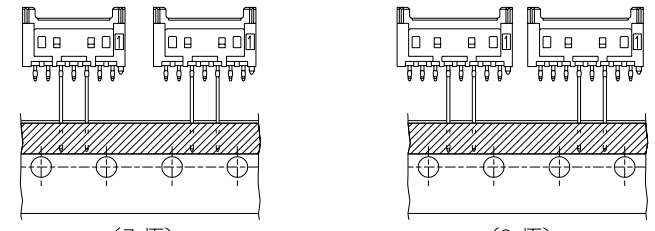

(7 極) (7 CKT.) (8 極) (8 CKT.)

極数別テーピング状態図
CKT. TAPING FORM

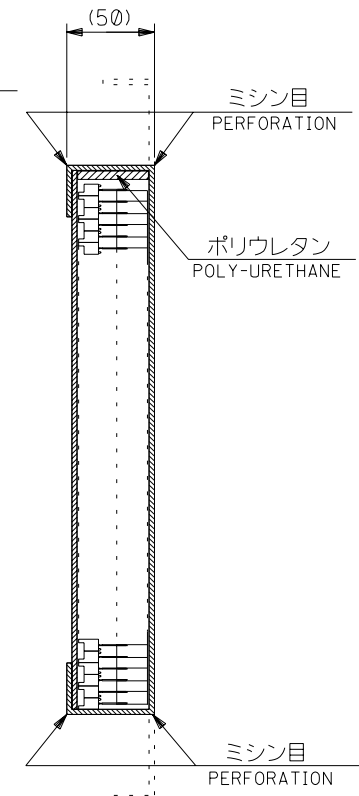
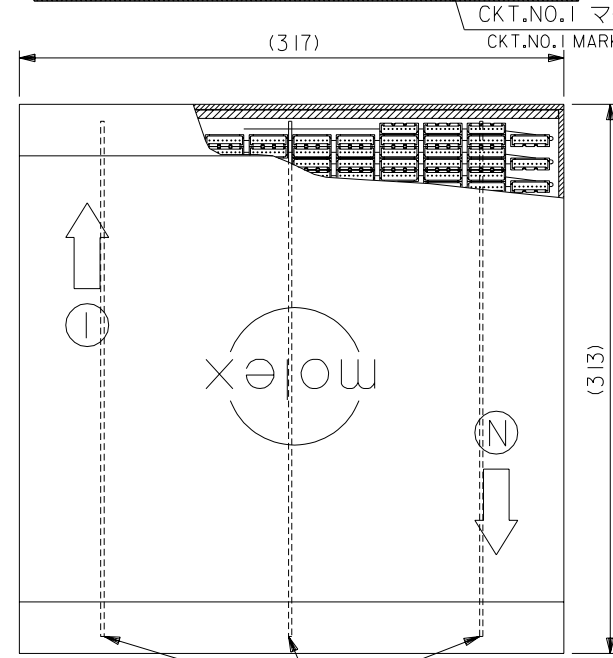
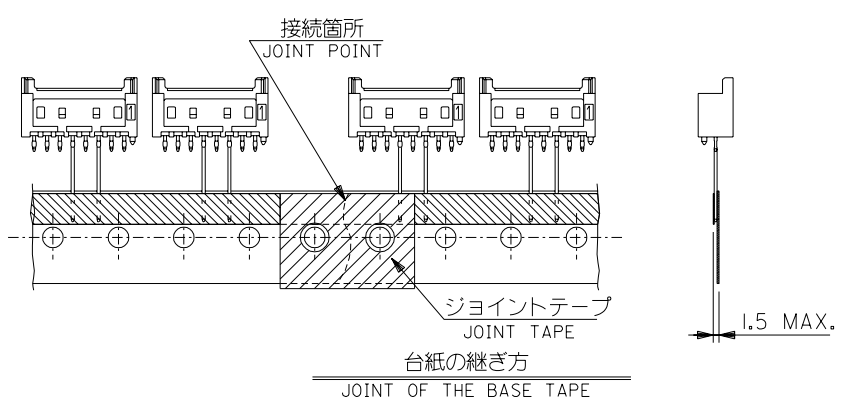

注記 NOTES

1. 包装形態はつづら折りで箱詰め。
RADIAL TAPE IS FOLDED AND PILED IN THE CARTON.
2. テーピングの両端には、5個以上の送り穴を設けること。
BOTH ENDS OF TAPING, MORE THAN 5 FEEDING HOLES SHOULD BE PROVIDED.
3. コネクタの欠落数は、D寸法 (SHEET 1 OF 2 参照) が12、7の場合連続3個まで、2.5、4の場合1個とする。(折り目ごとの1個抜きも含む)
ALLOWABLE NUMBERS OF CONSECUTIVE MISSING CONNECTORS:
FOR CONNECTORS WHERE D=12.7,=3(REFER TO SHEET 1 OF 2)
FOR CONNECTORS WHERE D=25.4,=1
4. 台紙の継ぎ目のずれは、いかなる方向からも±0.3以内とする。
MISMATCHED JOINT OF THE BASE TAPE SHOULD BE KEPT WITHIN ±0.3mm IN EVERY DIRECTIONS.
5. 図中指示以外の項目は、日本工業規格 JIS C0805 “電子部品のテーピング”を適用。
ITEMS UNLESS OTHERWISE SPECIFIED, JIS C 0805 (TAPING OF ELECTRONIC COMPONENTS) SHOULD BE APPLIED.

		材料 MATERIAL		SHEET 1 OF 2 参照 REFER TO SHEET 1 OF 2		molex MOLEX-JAPAN CO.,LTD. 日本モレックス株式会社	
E	変更 REVISION	(J2004-3573)	Y.W	M.S	04/04/05	REVISE ONLY ON CAD SYSTEM	
D	変更 REVISION	(J30223)	K.T	H.H	93/3/10	TITLE 名称	
C	変更 REVISION	(J3021)	K.T	H.H	93/2/9	適用電線範囲 WIRE RANGE	
B	変更 REVISION	(J30000)	H.H	M.F	93/1/7	被覆外径 INS. RANGE	
A	変更 REVISION	(J20671)	K.T	H.H	92/7/29	DRAWN BY '92/5/6 K.TOJO	
①	新規作成 PROPOSED	(J20390)	K.T	H.H	92/5/8	CHK'D BY '93/3/10 H.HIRAMOTO	
一般公差 GENERAL TOLERANCES		記号 LTR	変更内容 REVISION RECORD	DR. CHK.	日付 DATE	尺度 SCALE	—

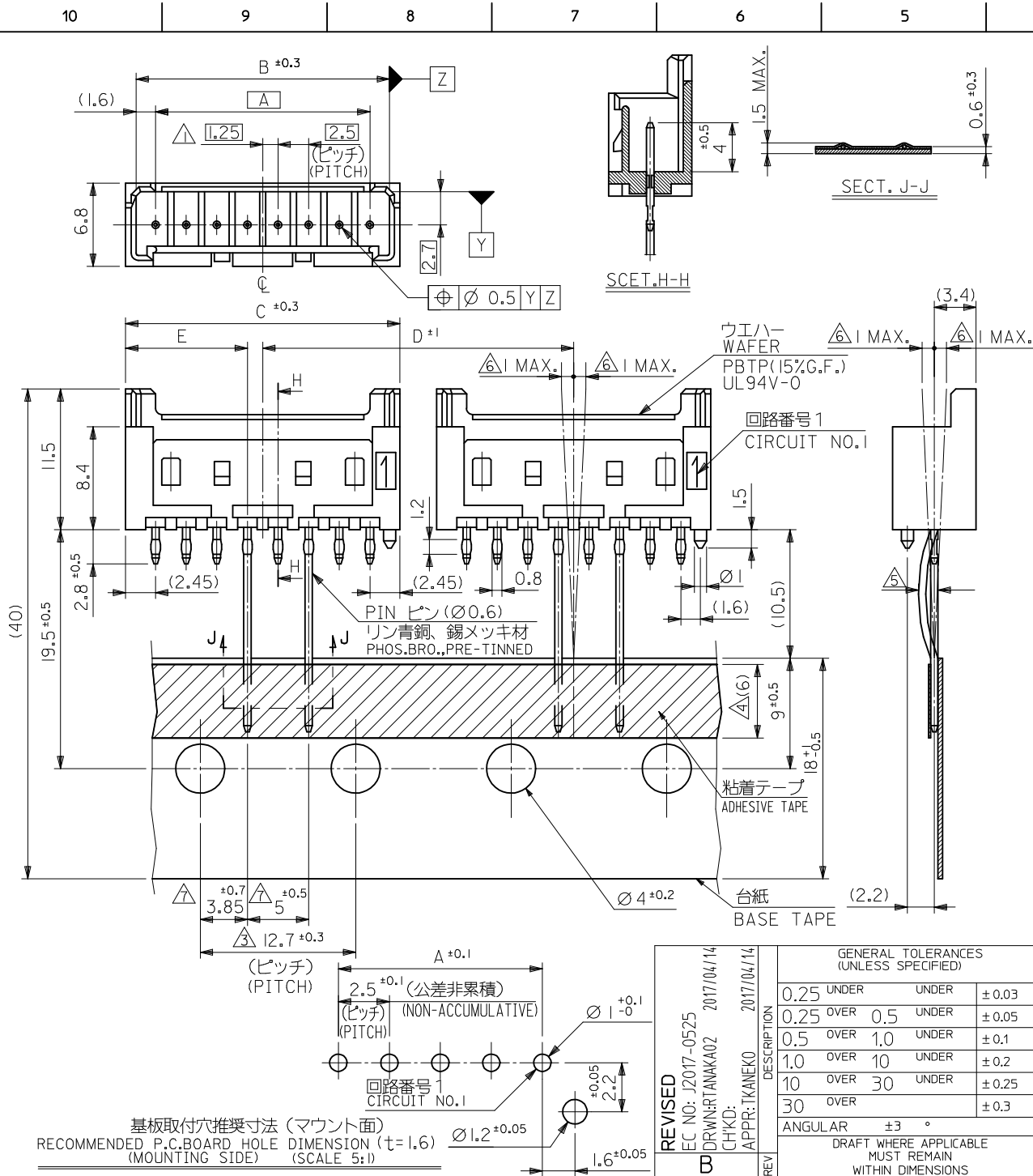

注記 NOTES

- △ 偶数極品に適用。
APPLIES ONLY TO EVEN NO. CKT. SIZES.
- 2. 嵌合相手：51103 シリーズ
MATES WITH:51103 SERIES.
- △ 累積ピッチの許容差は、20ピッチで ±1.0mm とする。
ACCUMULATED TOLERANCE IS TO BE ±1.0mm PER 20 PITCH.
- △ 粘着テープは台紙からはみ出さない事。
THE ADHESIVE TAPE SHOULD NOT BE PROTRUDED FROM THE BASE TAPE.
- △ リード線の曲がりの許容差は 1mm MAX. とする。
CAMBER OF THE LEADS : 1mm MAX.
- △ 測定位置は、コネクタの先端とする。
INCLINED POSITION FROM THE CENTER-LINE, SHOULD BE 1mm MAX.
MEASURING SHOULD BE DONE, USING THE TOP OF BASE TAPE AS DATUM.
- △ 測定値は台紙の上端とし、リード線との間隔とする。
DIM. 3.85 AND DIM. 5 SHOULD BE MEASURED ON THE TOP OF BASE TAPE. DIMENSIONS ARE A SPACING BETWEEN THE CENTER-LINES.
- 8. 製品番号の下1桁は色を表します。
LAST DIGIT OF PART NUMBER INDICATES COLOR.
0 : 白 WHITE 1 : 黒 BLACK 2 : 赤 RED
3 : 黄 YELLOW 4 : 青 BLUE 6 : 緑 GREEN

400	9.95	25.4	22.4	20.7	17.5	53375-089*	8
	7.45	↑	19.9	18.2	15	↑	-079* 7
500	7.45	↓	17.4	15.7	12.5	↓	-069* 6
	4.95	↓	14.9	13.2	10	↓	-059* 5
900	4.95	25.4	12.4	10.7	7.5	↓	-049* 4
	2.45	12.7	9.9	8.2	5	↓	-039* 3
包装数量/箱 QTY/CARTON	2.45	12.7	7.4	5.7	2.5	53375-029*	2
	MATERIAL NO. 極数 MODEL NO. 53375-**-9*						NO. OF

REVISED EC NO: J2017-0525 DRAWN: TANAKAO 2017/04/14 CHKD: APPR: KANEKO 2017/04/14	GENERAL TOLERANCES (UNLESS SPECIFIED)		DIMENSION STYLE MM ONLY		SCALE 3:1		DESIGN UNITS METRIC		THIRD ANGLE PROJECTION	
	0.25 UNDER	UNDER	±0.03	DRAWN BY	DATE	TITLE				
0.25 OVER	0.5 UNDER	±0.05	M.UMEDA	2005/01/21	2.5 WIRE TO BOARD CONN. WAFER ASSY RADIAL TAPING -LEAD FREE-					
0.5 OVER	1.0 UNDER	±0.1	CHECKED BY	DATE	molex					
1.0 OVER	10 UNDER	±0.2	K.TOYODA	2005/01/21						
10 OVER	30 UNDER	±0.25	APPROVED BY	DATE	DOCUMENT NO. SD-53375-004					
30 OVER		±0.3	N.UKITA	2005/01/21	SHEET NO. 1 OF 3					
ANGULAR ±3 °			MATERIAL NO.		SEE TABLE					
DRAFT WHERE APPLICABLE MUST REMAIN WITHIN DIMENSIONS			SIZE A3		THIS DRAWING CONTAINS INFORMATION THAT IS PROPRIETARY TO MOLEX ELECTRONIC TECHNOLOGIES, LLC AND SHOULD NOT BE USED WITHOUT WRITTEN PERMISSION					

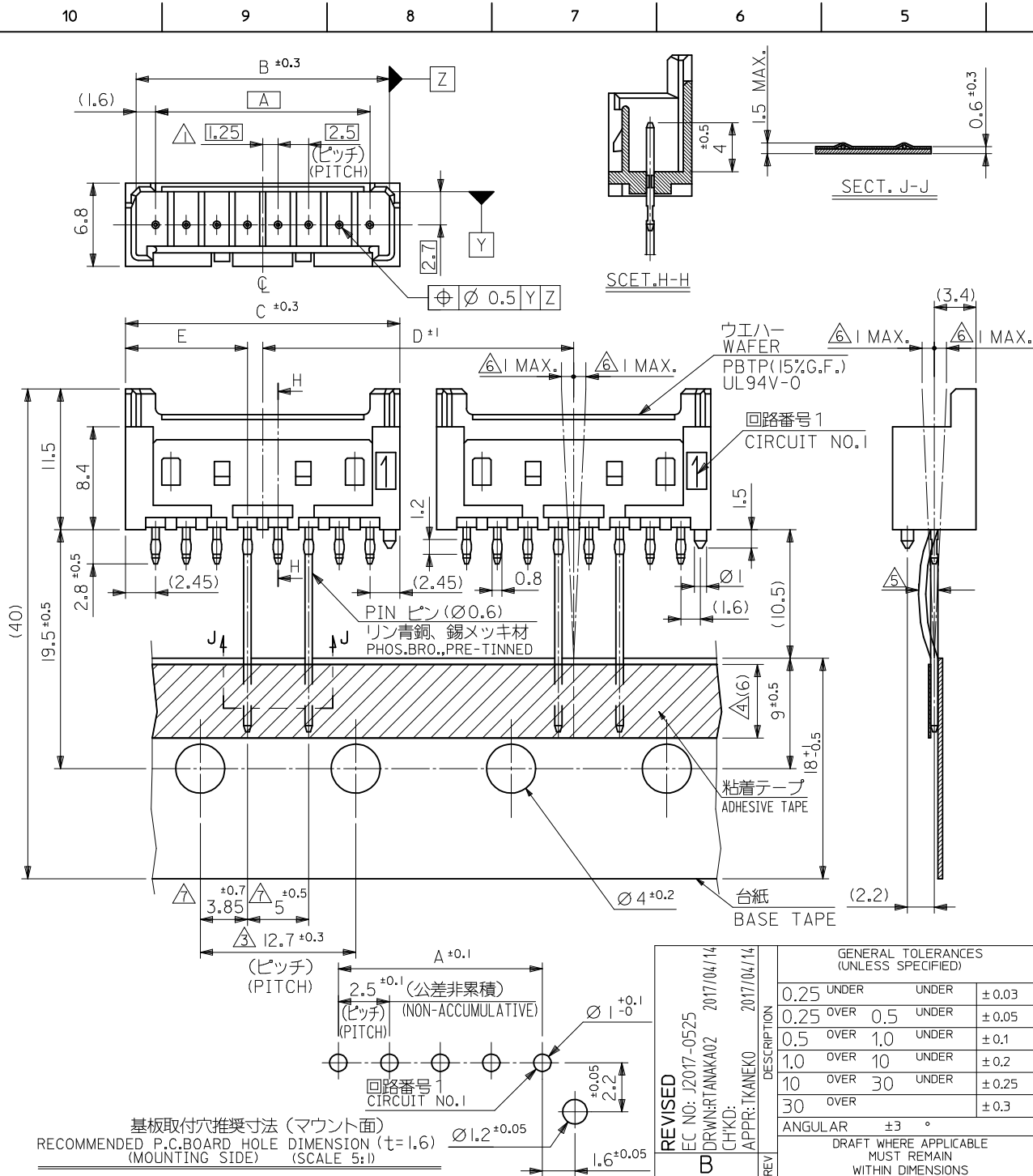

注記 NOTES

- △ 偶数極品に適用。
APPLIES ONLY TO EVEN NO. CKT. SIZES.
- 2. 嵌合相手：51103 シリーズ
MATES WITH:51103 SERIES.
- △ 累積ピッチの許容差は、20ピッチで ±1.0mm とする。
ACCUMULATED TOLERANCE IS TO BE ±1.0mm PER 20 PITCH.
- △ 粘着テープは台紙からはみ出さない事。
THE ADHESIVE TAPE SHOULD NOT BE PROTRUDED FROM THE BASE TAPE.
- △ リード線の曲がりの許容差は 1mm MAX. とする。
CAMBER OF THE LEADS : 1mm MAX.
- △ 測定位置は、コネクタの先端とする。
INCLINED POSITION FROM THE CENTER-LINE, SHOULD BE 1mm MAX.
MEASURING SHOULD BE DONE, USING THE TOP OF BASE TAPE AS DATUM.
- △ 測定値は台紙の上端とし、リード線との間隔とする。
DIM. 3.85 AND DIM. 5 SHOULD BE MEASURED ON THE TOP OF BASE TAPE. DIMENSIONS ARE A SPACING BETWEEN THE CENTER-LINES.
- 8. 製品番号の下1桁は色を表します。
LAST DIGIT OF PART NUMBER INDICATES COLOR.
0 : 白 WHITE 1 : 黒 BLACK 2 : 赤 RED
3 : 黄 YELLOW 4 : 青 BLUE 6 : 緑 GREEN

400	9.95	25.4	22.4	20.7	17.5	53375-089*	8
	7.45	↑	19.9	18.2	15	↑	-079* 7
500	7.45	↓	17.4	15.7	12.5	↓	-069* 6
	4.95	↓	14.9	13.2	10	↓	-059* 5
900	4.95	25.4	12.4	10.7	7.5	↓	-049* 4
	2.45	12.7	9.9	8.2	5	↓	-039* 3
包装数量/箱 QTY/CARTON	2.45	12.7	7.4	5.7	2.5	53375-029*	2
						MATERIAL NO.	極数 NO. OF
					MODEL NO.	53375-xx*9	2

REVISED EC NO: J2017-0525 DRAWN: TANAKAO 2017/04/14 CHKD: APPR: KANEKO 2017/04/14	GENERAL TOLERANCES (UNLESS SPECIFIED)		DIMENSION STYLE MM ONLY		SCALE 3:1	DESIGN UNITS METRIC	THIRD ANGLE PROJECTION
	0.25 UNDER	UNDER	±0.03	DRAWN BY M.UMEDA	DATE 2005/01/21	TITLE 2.5 WIRE TO BOARD CONN. WAFER ASSY RADIAL TAPING -LEAD FREE-	
0.25 OVER	0.5 UNDER	±0.05	CHECKED BY K.TOYODA	DATE 2005/01/21	APPROVED BY N.UKITA		DATE 2005/01/21
0.5 OVER	1.0 UNDER	±0.1	APPROVED BY DATE		MATERIAL NO.		DOCUMENT NO. SD-53375-004
1.0 OVER	10 UNDER	±0.2	APPROVED BY DATE		MATERIAL NO.		SHEET NO. 1 OF 3
10 OVER	30 UNDER	±0.25	APPROVED BY DATE		MATERIAL NO.		SHEET NO. 1 OF 3
30 OVER		±0.3	APPROVED BY DATE		MATERIAL NO.		SHEET NO. 1 OF 3
ANGULAR		±3 °	SIZE A3		THIS DRAWING CONTAINS INFORMATION THAT IS PROPRIETARY TO MOLEX ELECTRONIC TECHNOLOGIES, LLC AND SHOULD NOT BE USED WITHOUT WRITTEN PERMISSION		
DRAFT WHERE APPLICABLE MUST REMAIN WITHIN DIMENSIONS							