

Jun.1.2024 Copyright 2024 HIROSE ELECTRIC CO., LTD. All Rights Reserved.
 In case of consideration for using Automotive equipment / device which demand high reliability, kindly contact our sales window correspondents.

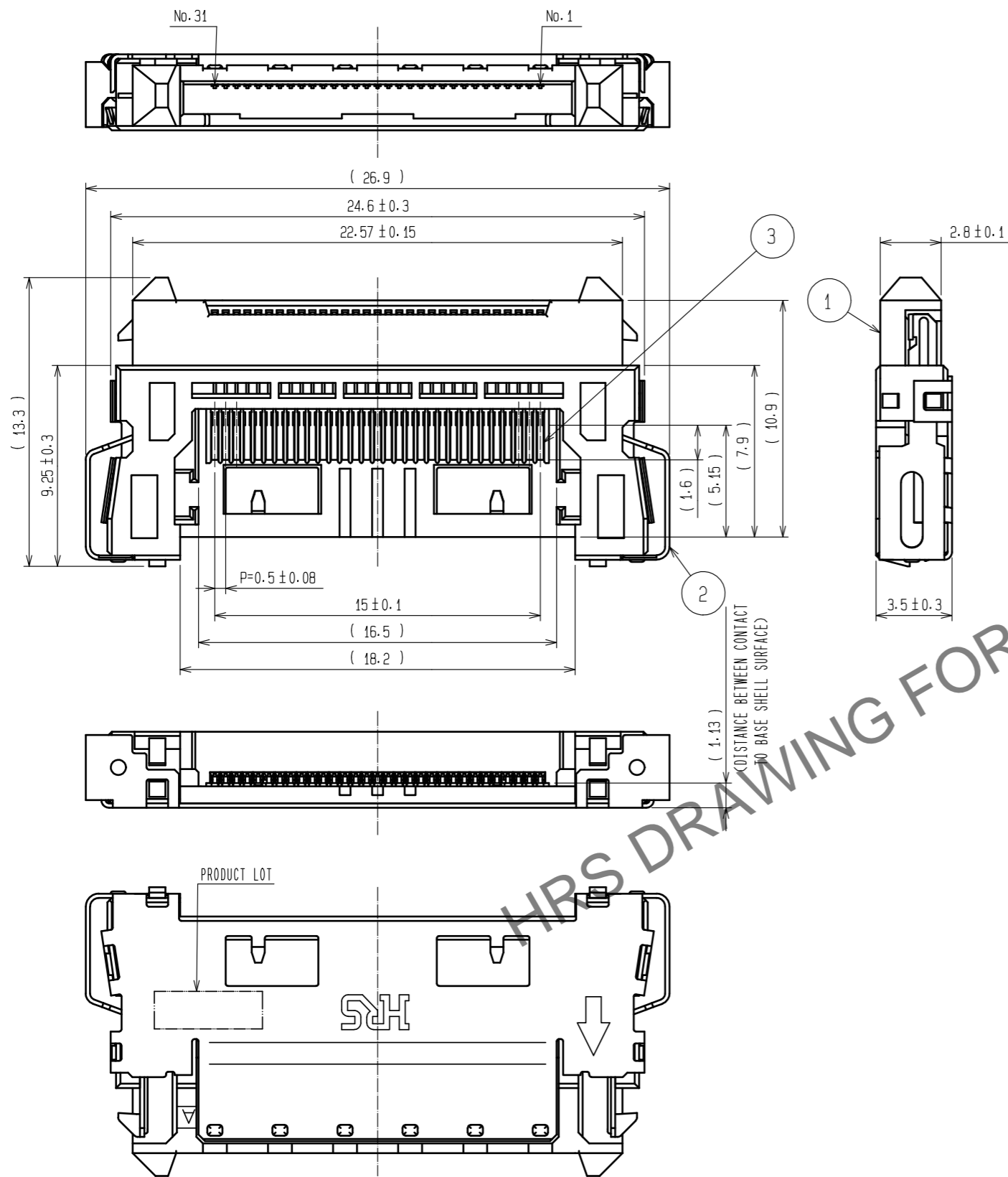

APPLICATION DIAGRAM (2:1)

Deleted

Deleted

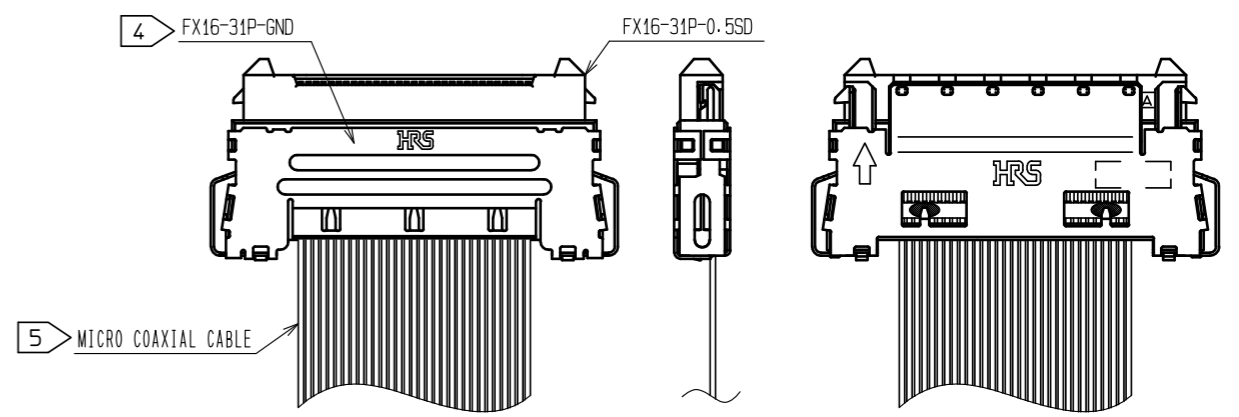

- NOTE 1 () INDICATES A REFERENCE DIMENSION.
 2 MANUFACTURING PROCESS COULD LEAVE SCRATCH AND/OR PUNCH MARKS HAVING NO AFFECT ON THE PRODUCT PERFORMANCE. AND THE DARK SPOTS MIGHT OCCASIONALLY OCCUR ON MOLDED PLASTIC.
 3 THE CONNECTORS ARE DELIVERED IN TRAY PACKAGING.
 4 COVER SHELL IS SEPARATELY AVAILABLE.
 5 THE ACCEPTABLE CABLE OF THE CONNECTOR IS MICRO COAXIAL CABLE:36-40AWG. CABLE PREPARATION IS REQUIRED PRIOR TO CABLE ASSEMBLY. REFER TO PAGE 3 FOR THE RECOMMENDED CABLE PROCESS DIMENSIONS.
 6 REFER TO PAGE 4 FOR THE CABLE ASSEMBLY PROCEDURES AND PRECAUTIONS FOR HANDLING.

4	PS	(TRAY)							CONTACT AREA:GOLD 0.1μm min
2	STAINLESS	NICKEL 0.3μm min				3	PHOSPHOR BRONZE		TERMINAL AREA:TIN-PLATING 2μm min
1	PA	BEIGE	UL94V-0						UNDER PLATING:NICKEL 1μm min
NO.	MATERIAL	FINISH	REMARKS	NO.	MATERIAL	FINISH	REMARKS		
UNITS mm		SCALE 4 : 1		COUNT 14	DESCRIPTION OF REVISIONS DIS-F-00005761		DESIGNED MM. ISHII	CHECKED HT. YAMAGUCHI	DATE 20200326
HRS HIROSE ELECTRIC CO., LTD.		APPROVED : HS. OKAWA	20110301	DRAWING NO. EDC3-157674-01					
		CHECED : HT. YAMAGUCHI	20110301	PART NO. FX16-31P-0.5SD					
		DESIGNED : SY. KAMIGA	20110301	CODE NO. CL575-3302-0-00					
		DRAWN : HK. SUNADORI	20110301						

Jun.1.2024 Copyright 2024 HIROSE ELECTRIC CO., LTD. All Rights Reserved.
In case of consideration for using Automotive equipment / device which demand high reliability, kindly contact our sales window correspondents.

DRAWING FOR PACKING (1:2)

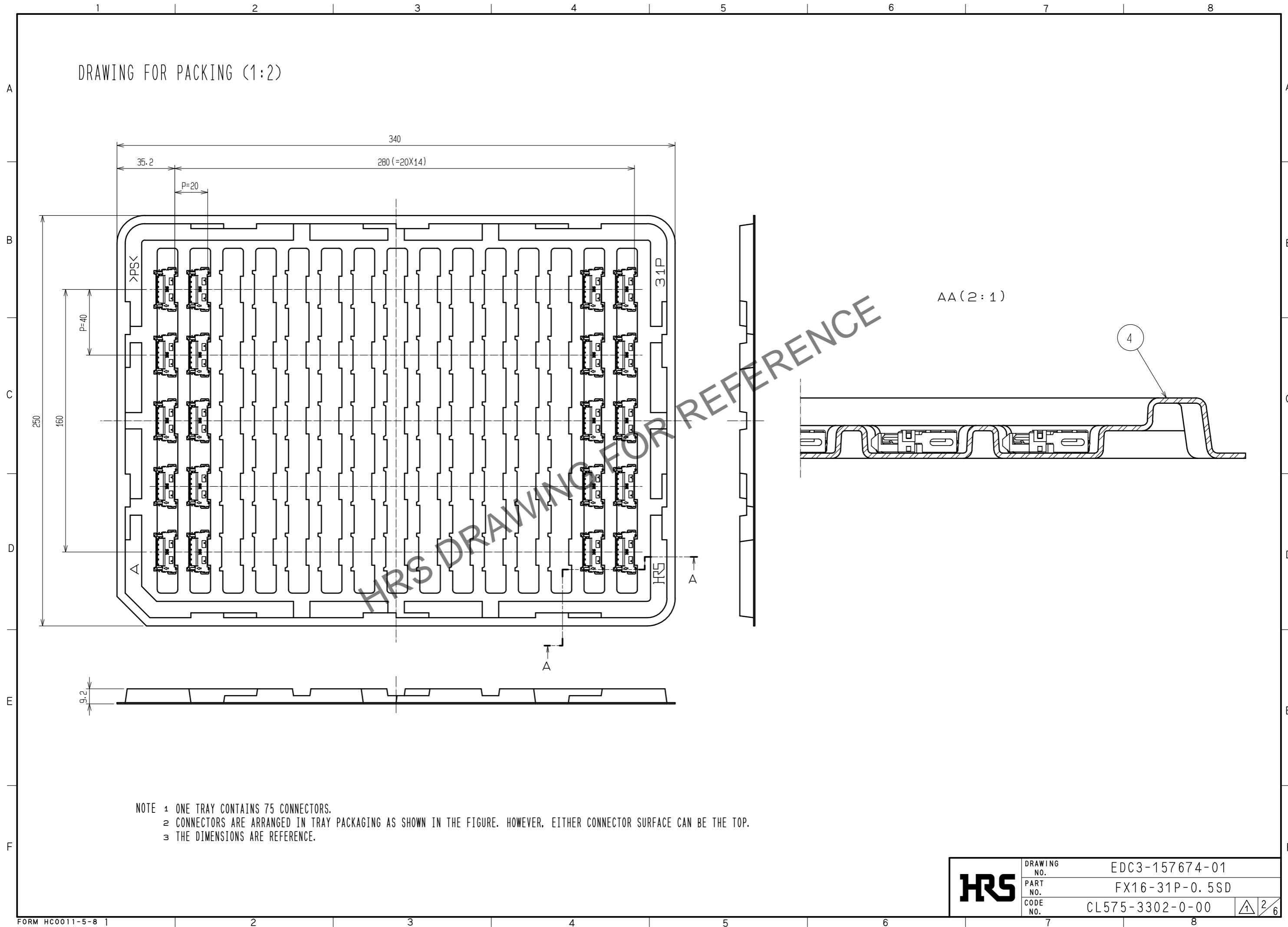

- NOTE 1 ONE TRAY CONTAINS 75 CONNECTORS.
2 CONNECTORS ARE ARRANGED IN TRAY PACKAGING AS SHOWN IN THE FIGURE. HOWEVER, EITHER CONNECTOR SURFACE CAN BE THE TOP.
3 THE DIMENSIONS ARE REFERENCE.

HRS	DRAWING NO.	EDC3-157674-01
	PART NO.	FX16-31P-0.5SD
	CODE NO.	CL575-3302-0-00
		2/6

Jun.1.2024 Copyright 2024 HIROSE ELECTRIC CO., LTD. All Rights Reserved.
 In case of consideration for using Automotive equipment / device which demand high reliability, kindly contact our sales window correspondents.

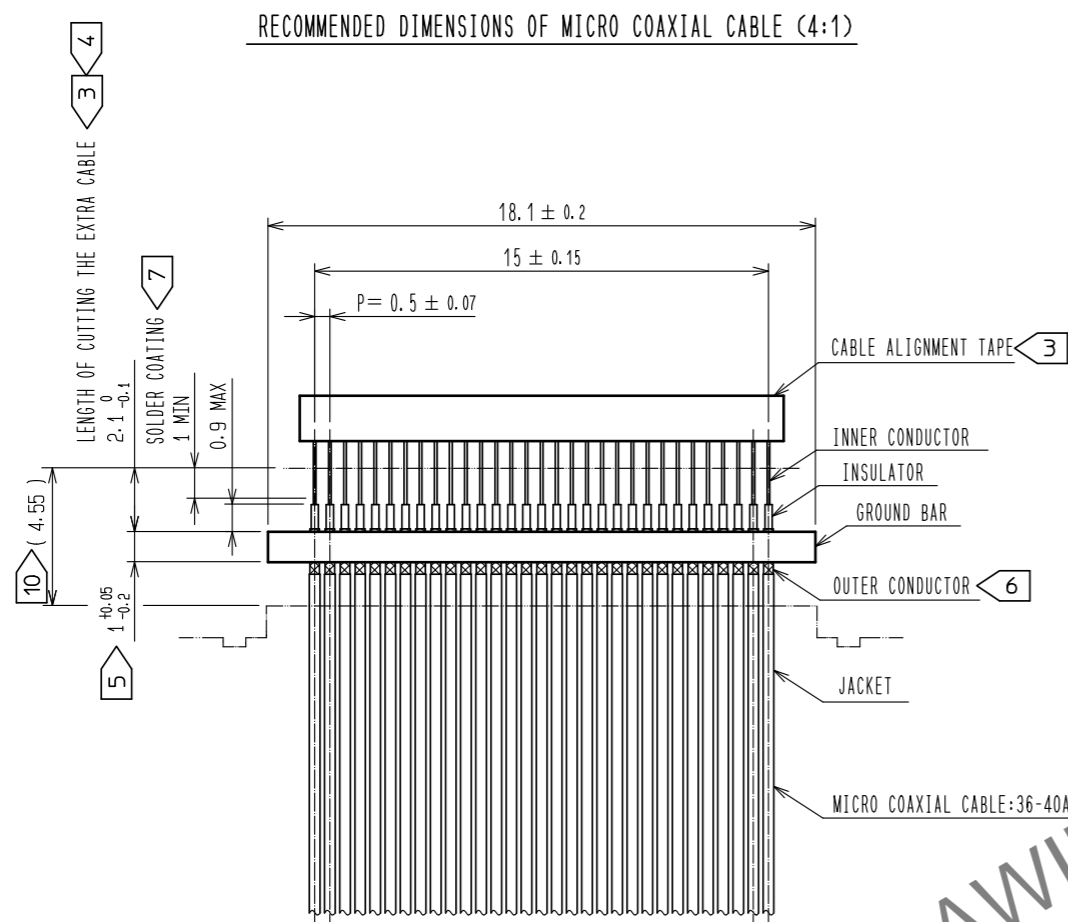

Deleted

HRS DRAWING FOR REFERENCE

- NOTE 1 () INDICATES A REFERENCE DIMENSION.
- 2 SOLDERING TO THE CONNECTOR AT ONCE BY USING PULSE HEAT IS RECOMMENDED.
 - 3 TO PREVENT CONDUCTOR DEFORMATION, CUT THE CABLE ALIGNMENT TAPE AT THE SPECIFIED POSITION JUST BEFORE THE CABLE ASSEMBLY.
 - 4 MINIMAL LENGTH 2.0 mm IS A RECOMMENDED DIMENSION AND ALLOWED TO BE CHANGED IF NECESSARY, AS LONG AS ENSURING GOOD SOLDERABILITY.
 - 5 WIDTH OF GROUND BAR SHALL BE 1.05 mm MAX. INCLUDING MISALIGNMENT OF OVERLAPPING, FLUSH BY CUTTING, SIDE DROP OR SOLDERING. USING AN INADEQUATE CABLE WILL INTERFERE THE ASSEMBLY TO THE CONNECTOR. FORCEFUL ASSEMBLY AND SOLDERING COULD CAUSE MIS-SOLDERING TO DEFECTIVE PRODUCT.
 - 6 MINIMIZE THE LENGTH OF OUTER CONDUCTOR BEYOND THE GROUND BAR.
 - 7 PRE-SOLDER AND COAT THE INNER CONDUCTOR AT THE CABLE END.

- Deleted
- Deleted
- SHOWS THE CABLE ASSEMBLY POSITION AND THE CABLE LENGTH FITTING INTO THE CONNECTOR WHEN THE CABLE IS CUT AT THE RECOMMENDED CUTTING POSITION OF EXTRA CABLE LENGTH.

HRS	DRAWING NO.	EDC3-157674-01
	PART NO.	FX16-31P-0.5SD
	CODE NO.	CL575-3302-0-00

3/6

Jun.1.2024 Copyright 2024 HIROSE ELECTRIC CO., LTD. All Rights Reserved.
In case of consideration for using Automotive equipment / device which demand high reliability, kindly contact our sales window correspondents.

Cautions for soldering

1. Recommended solder

Flux cored solder (Lead-free: Sn-3Ag-0.5Cu)
Micro coaxial cable · · · 0.15 mm dia. Length 15.5 mm

⚠ Deleted

If you consider using additional flux, please pay enough attention not to have flux wicking to the contact area.
Flux wicking to the contact area will cause contact failure.

2. Setting the cable

Set the conductors as each conductor is placed at the center of the contact.
In case of micro coaxial cable, set it as the metal bar fits in the guide on the connector.

⚠ Deleted

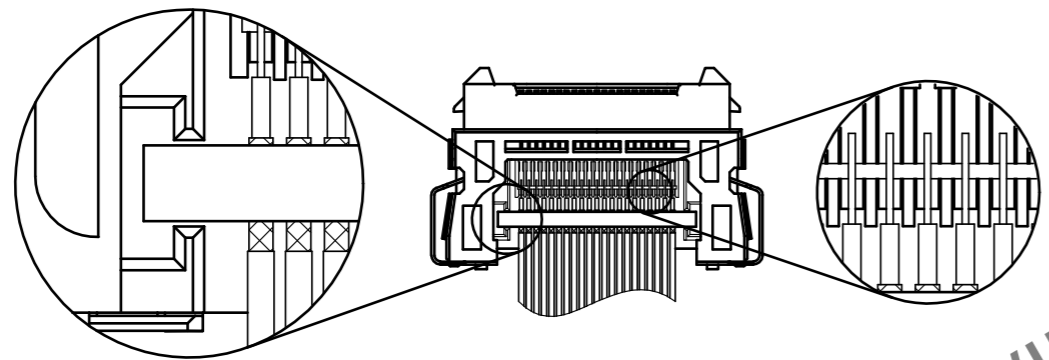

⚠ Deleted

3. Place the cable to the connector and check the below points before soldering by pulse heat.

- Transformation of conductor
 - Misalignment of conductor to the terminals in pitch direction
 - Excessive floating of conductor
- The above could cause soldering failure and/or solder bridge.

Transformation of conductor

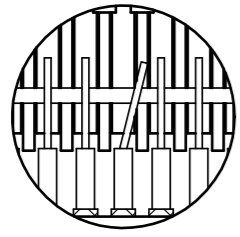

Misalignment in pitch direction

⚠ Deleted

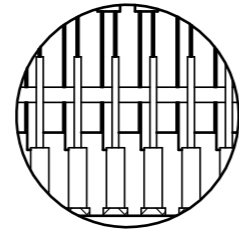

Floating

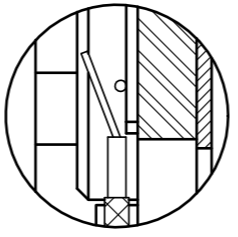

4. Follow the recommended temperature profile shown below for the soldering.

The optimum condition could vary depending on various factors including type of cable and its length, solder type. Therefore refer to the recommended temperature profile and optimize the condition if necessary.

Solder tip pressurization	13 ~ 17 N
---------------------------	-----------

heating	Micro coaxial cable
Temperature (Y)	275± 5 °C
Duration (X)	2± 0.5 sec

⚠ Deleted

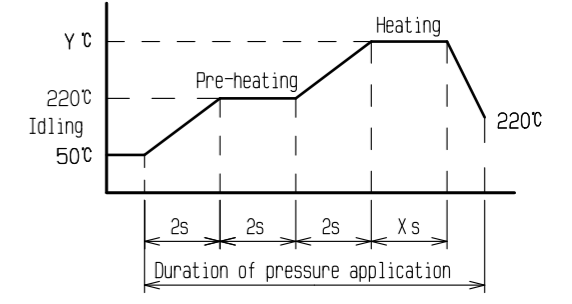

5. After soldering, check that no defect is found at soldered area.

Examples of correct soldered and defective soldered state are shown below.

Correct soldering

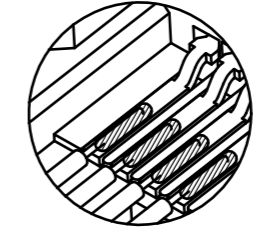

Conductors are placed at the center of the contact, and whole area is equally wetted.

Defective soldered state

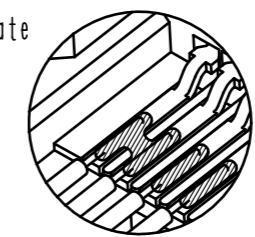

Solder bridge

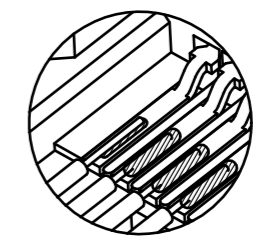

Solder shortage

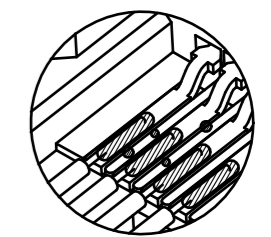

Solder ball dispersion

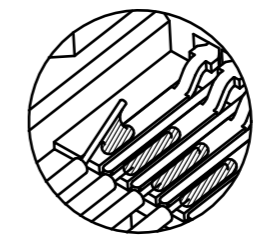

Floating

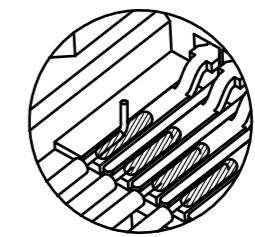

Conductor sticking out

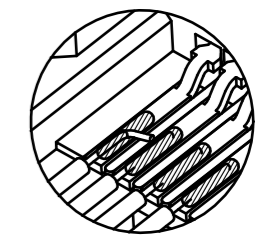

The conductor approaches to the adjacent contact

*Note: The figures shown in this page are solely for the instruction purpose. Therefore, the appearance could differ from the actual connectors. Refer to the drawing for the actual design (sheet 1).

HRS	DRAWING NO.	EDC3-157674-01
	PART NO.	FX16-31P-0.5SD
	CODE NO.	CL575-3302-0-00
		⚠ 4/6

Jun.1.2024 Copyright 2024 HIROSE ELECTRIC CO., LTD. All Rights Reserved.
In case of consideration for using Automotive equipment / device which demand high reliability, kindly contact our sales window correspondents.

Cautions for potting process

1. Protect the soldered area by UV cured resin or any equivalent (referred to as 'potting' hereafter). In order to prevent insulating failure caused by metal adhering, cable breakage during cabling and other troubles.
2. Apply 3033 manufactured by THREEBOND CO., LTD. or any equivalent product for potting. Follow the instruction of potting manufacture's for the condition of UV exposure.
3. Refer to the following conditions for the potting area.

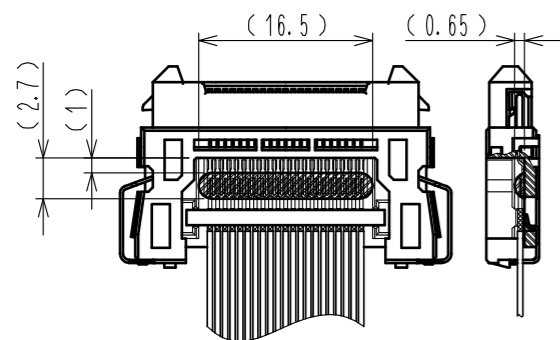

Deleted

3. Check the six fitting points after assembly and make sure that they are all correctly fitted together.

How to check fitting points
(Cut section of fitting points)

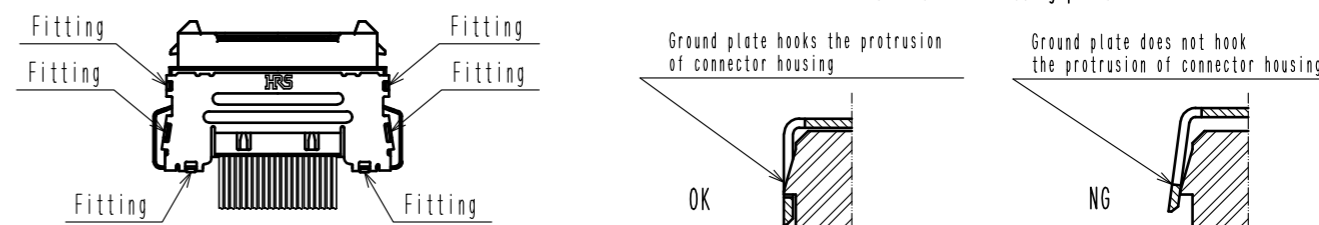

Soldering to ground plate

1. Solder down the metal bar of the cable and ground plate after the assembly of ground plate in order to enhance the grounding performance and robustness against cable stroke to up and down direction.

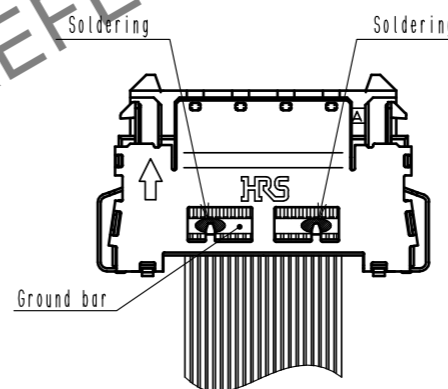

Deleted

Cautions for cover shell assembly

1. Attach a cover shell separately provided after the cable assembly process.
For micro coaxial cable : FX16-31P-GND
Deleted
2. Place the cover shell onto the connector horizontally and pinch two components from top and bottom with fingers.

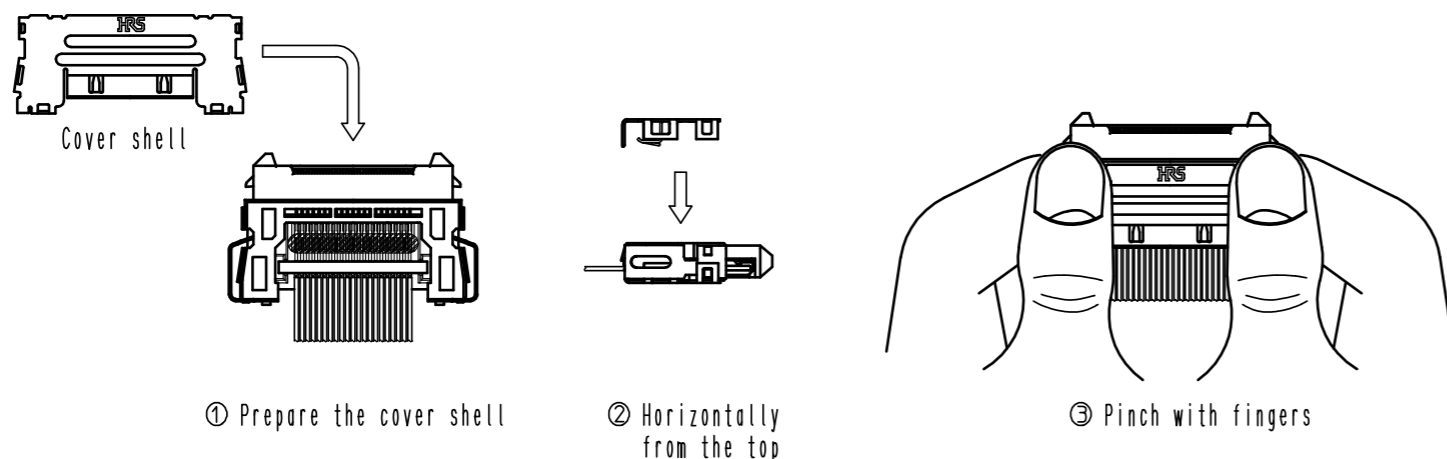

2. Excess solder and/or excess heating could cause cable and connector deformation and/or melt.

Cable assembly process is completed.

*Note: The figures shown in this page are solely for the instruction purpose. Therefore, the appearance could differ from the actual connectors. Refer to the drawing for the actual design (sheet 1).

HRS	DRAWING NO.	EDC3-157674-01
	PART NO.	FX16-31P-0.5SD
	CODE NO.	CL575-3302-0-00

HANDLING INSTRUCTIONS

[1] Insertion to on-board connector

The connector mating is keyed. Align the marks as shown in the figure for mating. Insert the connector completely until they are locked at both ends.

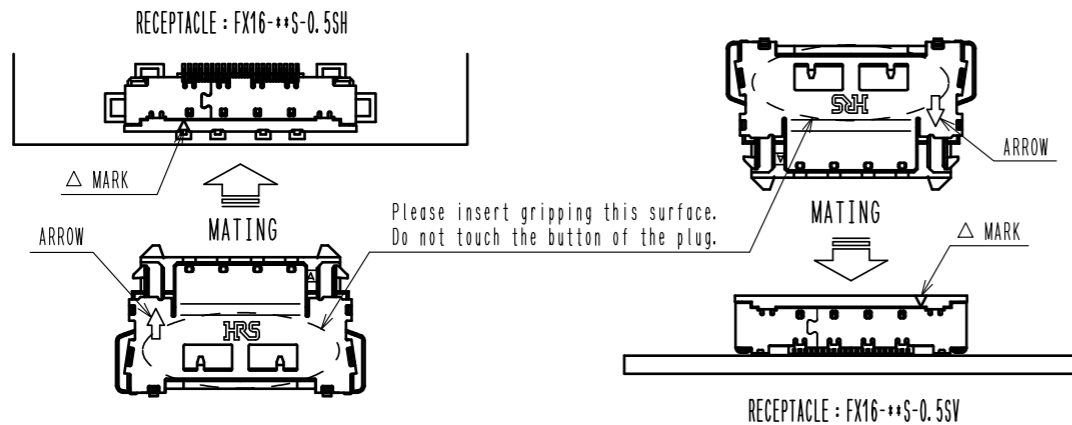

The connectors have a reverse-insertion prevention structure, however, the connectors may be damaged when inserted reversely with the force of 25 N or more. Avoid a forceful insertion, and make sure to confirm that the connectors are aligned with the marks before the mating operation.

[2] After mating

Carefully wire cables, so that excessive force will not be applied to the mated connectors. Pulling the cable with the force of 20 N or more may damage the connectors. It may also cause cable breakage. Take a caution to avoid pulling the cables.

Repetitive cable strokes could also cause cable breakage as well. Do not use the connector under the environment of repetitive cable strokes.

Take enough bend radius and/or distance from the connector for the cable not to apply stress to the connector base when the application requires cable bend back.

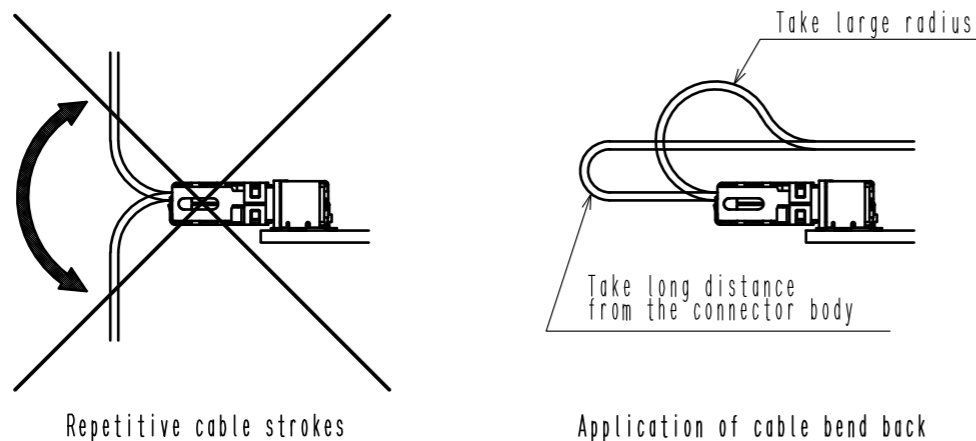

[3] Withdrawal from on-board connector

The connectors are locked while they are mated. In order to unmate the connectors, pull out straight, with the button pushed to release the lock. At this time, do not pull the cable. Also, avoid the withdrawal in angle, which may damage the connectors.

<Correct withdrawal>

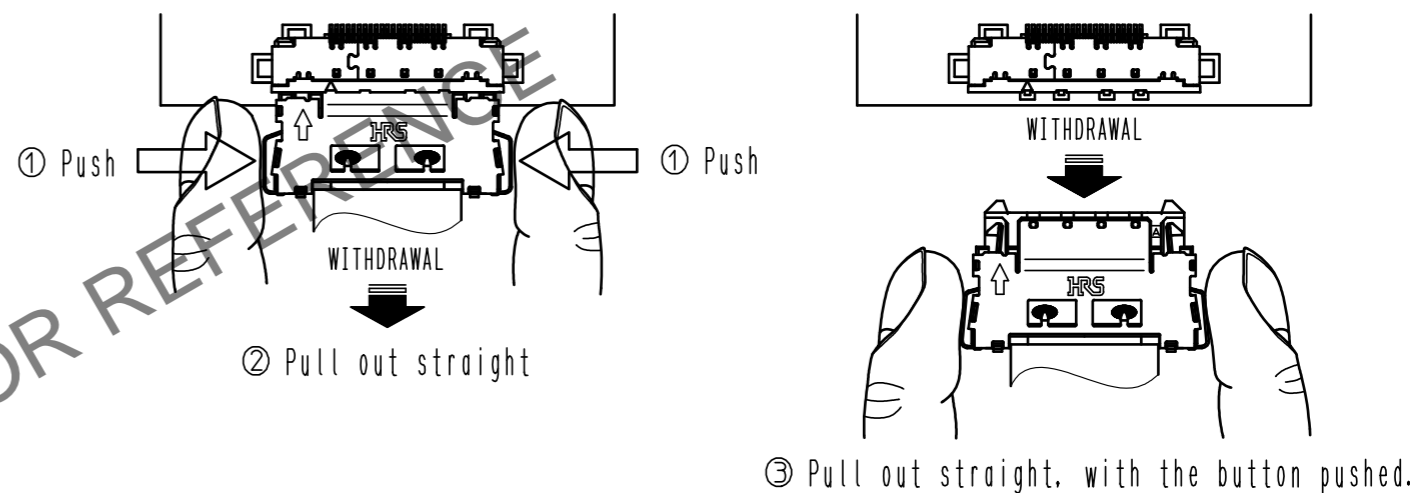

<Incorrect withdrawal>

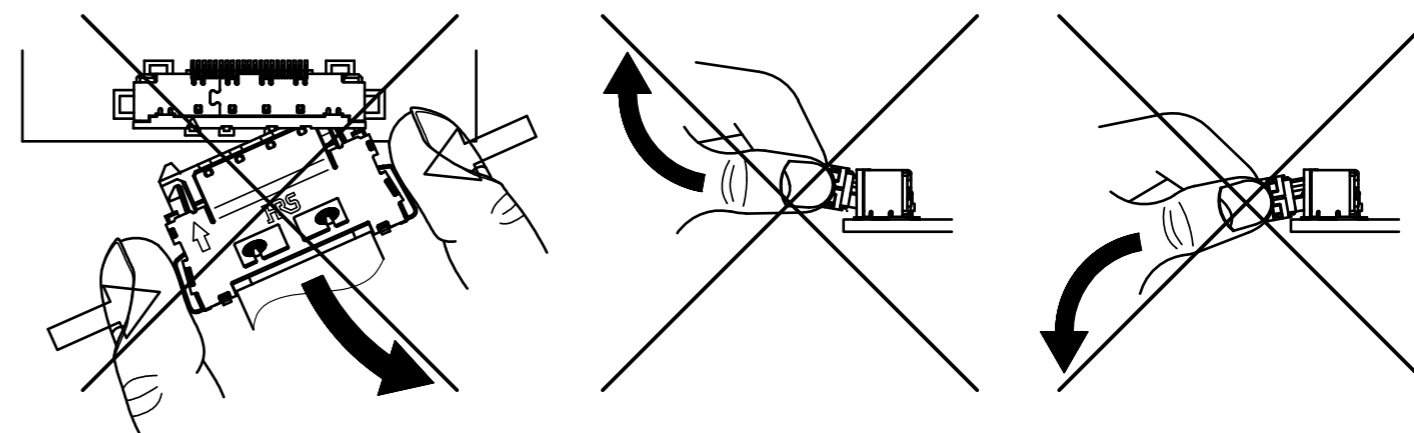

*Note : The connectors shown in this 'HANDLING INSTRUCTIONS' are drawn for the instruction purpose, therefore, the appearance differs from the actual connectors. Please confirm the connector configuration on the connector drawing (SHEET 1).

HRS	DRAWING NO.	EDC3-157674-01	6/6
	PART NO.	FX16-31P-0.5SD	
	CODE NO.	CL575-3302-0-00	

Jun.1.2024 Copyright 2024 HIROSE ELECTRIC CO., LTD. All Rights Reserved. In case of consideration for using Automotive equipment / device which demand high reliability, kindly contact our sales window correspondents.