

# CIPOS™ Tiny IPM 600V/10A

IM393-M6F

## Description

IM393-M6F is a 10A, 600V Integrated Power Hybrid IC with Open Emitter pins for advanced Appliance Motor Drives applications such as energy efficient fan and pumps. Infineon's technology offers an extremely compact, high performance AC motor-driver in a single isolated package to simplify design.

This advanced IPM is a combination of Infineon's newest low VCE(on) Trench IGBT technology optimized for best trade-off between conduction and switching losses and the industry benchmark 3 phase high voltage, high speed driver (3.3V compatible) in a fully isolated thermally enhanced package. A built-in high precision temperature monitor and over-current protection feature, along with the short-circuit rated IGBTs and integrated under-voltage lockout function, deliver high level of protection and fail-safe operation. Using a single in line package with full transfer mold structure resolves isolation problems to heatsink.

## Features

- Integrated gate drivers and bootstrap function
- Temperature monitor
- Protection shutdown pin
- Low VCE (on) Trench IGBT technology
- Under voltage lockout for all channels
- Matched propagation delay for all channels
- 3.3V Schmitt-triggered input logic
- Cross-conduction prevention logic
- Isolation 2000V<sub>RMS</sub> min and CTI > 600
- Recognized by UL (File Number : E314539)

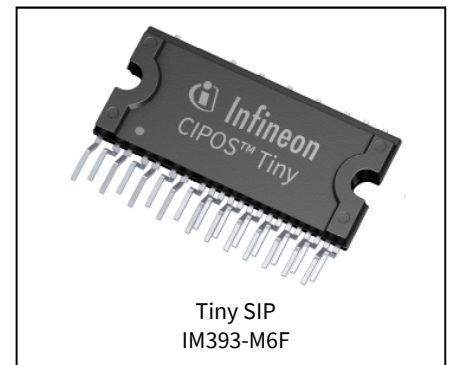

## Potential applications

- Washing machines
- Air-conditioners
- Refrigerators
- Fans
- Dishwashers
- Low power motor drives

## Product validation

Qualified for industrial applications according to the relevant tests of JEDEC47/20/22.

**Table1 Part Ordering Table**

Base part number	Package Type	Standard Pack	
		Form	Quantity
IM393-M6F	SIP 34x15	36 Tubes	540

**Table of Contents**

**Table of Contents**

<b>Description .....</b>	<b>1</b>
<b>Features .....</b>	<b>1</b>
<b>Potential Applications .....</b>	<b>1</b>
<b>Product validation .....</b>	<b>1</b>
<b>Table of Contents .....</b>	<b>2</b>
<b>1 Internal Electrical Schematic .....</b>	<b>3</b>
<b>2 Pin Configuration .....</b>	<b>4</b>
2.1 Pin Assignment .....	5
2.2 Pin Descriptions .....	6
<b>3 Absolute Maximum Rating .....</b>	<b>8</b>
3.1 Module .....	8
3.2 Inverter .....	8
3.3 Control .....	8
<b>4 Thermal Characteristics .....</b>	<b>9</b>
<b>5 Recommended Operating Conditions .....</b>	<b>10</b>
<b>6 Static Parameters .....</b>	<b>11</b>
6.1 Inverter .....	11
6.2 Control .....	11
<b>7 Dynamic Parameters .....</b>	<b>13</b>
7.1 Inverter .....	13
7.2 Control .....	13
<b>8 Thermistor Characteristics .....</b>	<b>14</b>
<b>9 Mechanical Characteristics and Ratings .....</b>	<b>15</b>
<b>10 Qualification Information .....</b>	<b>16</b>
<b>11 Diagrams &amp; Tables .....</b>	<b>17</b>
11.1 T <sub>c</sub> Measurement Point .....	17
11.2 Input-Output Logic Table .....	17
11.3 Switching Time Definitions .....	18
<b>12 Application Notes .....</b>	<b>19</b>
12.1 Typical Application Schematic .....	19
12.2 Performance Charts .....	20
12.3 T <sub>J</sub> vs T <sub>TH</sub> .....	20
12.4 -V <sub>S</sub> Immunity .....	21
<b>13 Package Outline .....</b>	<b>22</b>
<b>Revision History .....</b>	<b>23</b>

# 1 Internal Electrical Schematic

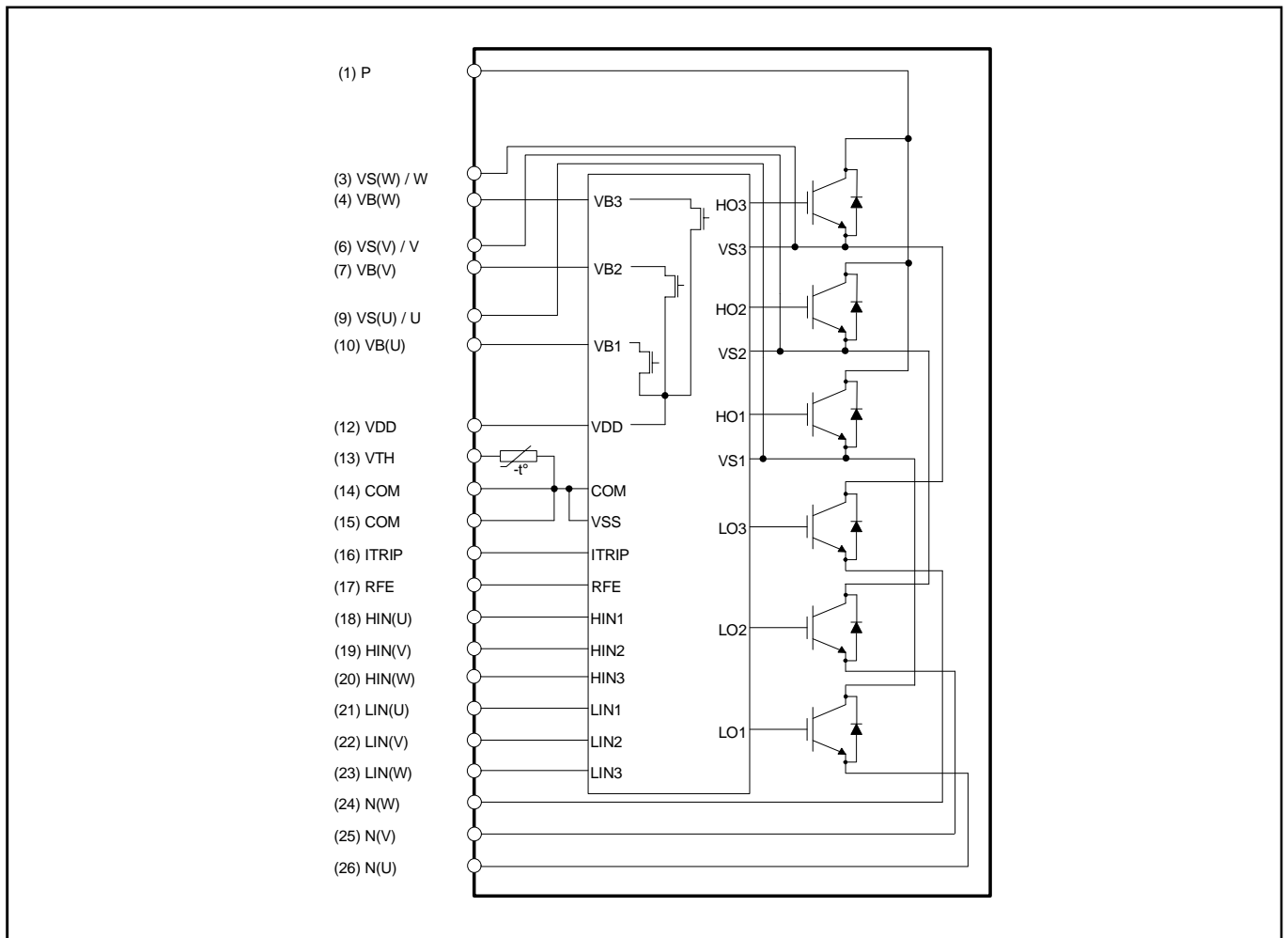

Figure 1 Internal electrical schematic

## 2 Pin Configuration

### 2.1 Pin Assignment

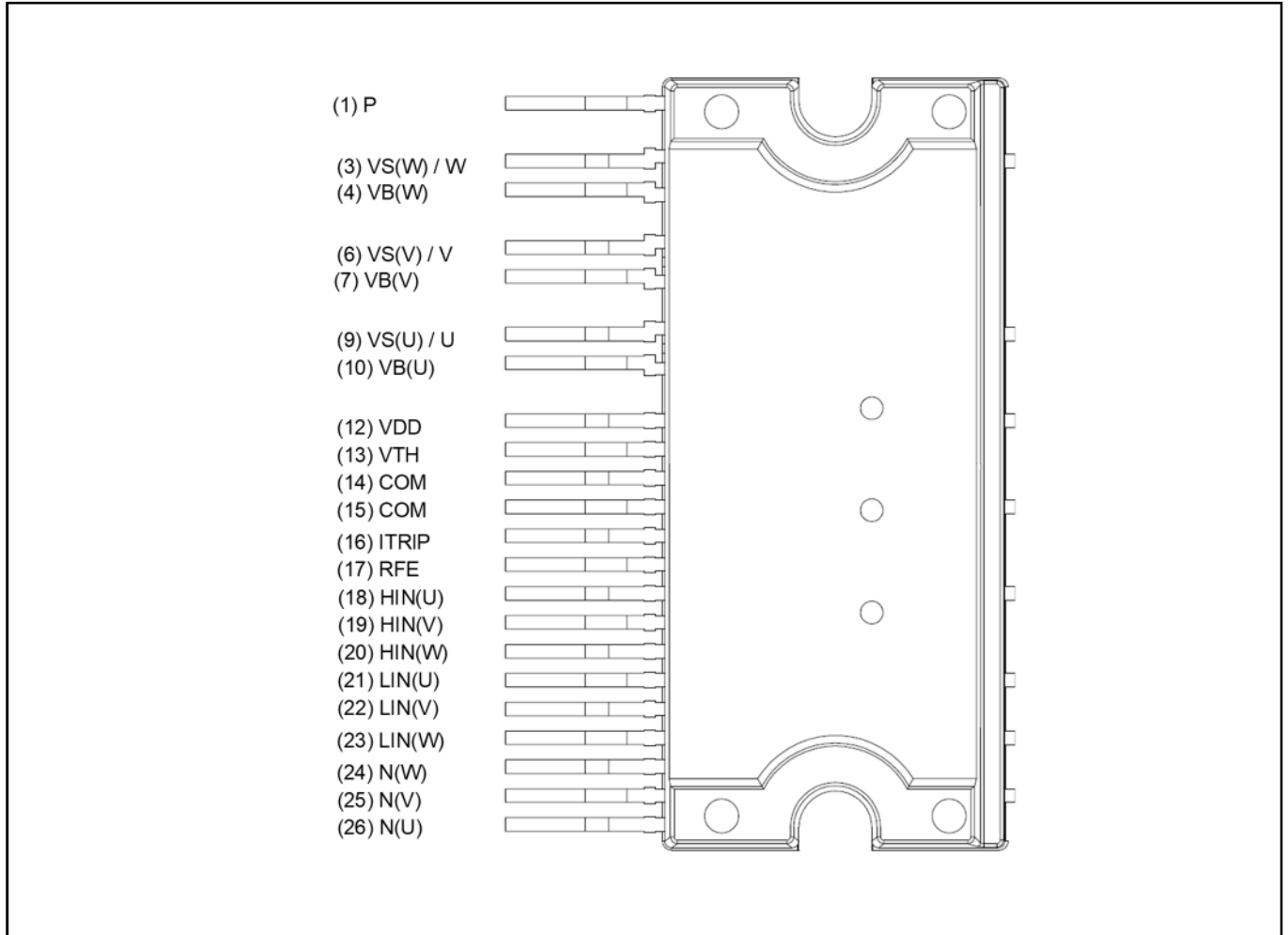

Figure 2 Pin configuration

**Pin Configuration**

**Table 2 Pin Assignment**

Pin	Name	Description
1	P	Positive bus input voltage
( 2 )	N/A	None
3	VS(W) / W	W-phase high side floating supply offset voltage / W-phase output
4	VB(W)	W-phase high side floating supply voltage
( 5 )	N/A	None
6	VS(V) / V	V-phase high side floating supply offset voltage / V-phase output
7	VB(V)	V-phase high side floating supply voltage
( 8 )	N/A	None
9	VS(U) / U	U-phase high side floating supply offset voltage / U-phase output
10	VB(U)	U-phase high side floating supply voltage
( 11 )	N/A	None
12	VDD	Low side control supply
13	VTH	Temperature monitor
14	COM	Low side control negative supply
15	COM	Low side control negative supply
16	ITRIP	Over current protection input
17	RFE	RCIN / Fault / Enable
18	HIN(U)	U-phase high side gate driver input
19	HIN(V)	V-phase high side gate driver input
20	HIN(W)	W-phase high side gate driver input
21	LIN(U)	U-phase low side gate driver input
22	LIN(V)	V-phase low side gate driver input
23	LIN(W)	W-phase low side gate driver input
24	N(W)	W-phase low side emitter
25	N(V)	V-phase low side emitter
26	N(U)	U-phase low side emitter

## 2.2 Pin Descriptions

### HIN(U,V,W) and LIN(U,V,W) (Low side and high side control pins)

These pins are positive logic and they are responsible for the control of the integrated IGBT. The Schmitt-trigger input thresholds of them are such to guarantee LSTTL and CMOS compatibility down to 3.3V controller outputs. Pull-down resistor of about 4kΩ is internally provided to pre-bias inputs during supply start-up and an ESD diode is provided for pin protection purposes. Input Schmitt-trigger and noise filter provide beneficial noise rejection to short input pulses.

The noise filter suppresses control pulses which are below the filter time  $T_{FILIN}$ . The filter acts according to Figure 4.

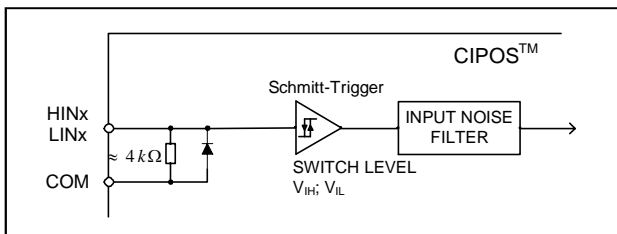

**Figure 3** Input pin structure

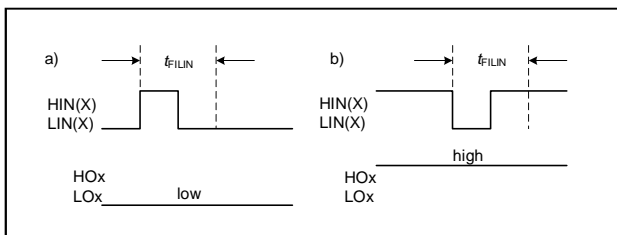

**Figure 4** Input filter timing diagram

The integrated gate drive provides additionally a shoot through prevention capability which avoids the simultaneous on-state of the high-side and low-side switch of the same inverter phase. A minimum dead time insertion of typically 275ns is also provided by driver IC, in order to reduce cross-conduction of the external power switches.

### V<sub>DD</sub>, COM (Low side control supply and reference

V<sub>DD</sub> is the control supply and it provides power both to input logic and to output power stage. Input logic is referenced to COM ground.

The under-voltage circuit enables the device to operate at power on when a supply voltage of at least a typical voltage of  $V_{DDUV+} = 10.4V$  is present.

The IC shuts down all the gate drivers power outputs, when the V<sub>DD</sub> supply voltage is below  $V_{DDUV-} = 9.4V$ . This prevents the external power switches from critically low gate voltage levels during on-state and therefore from excessive power dissipation.

### V<sub>B(U,V,W)</sub> and V<sub>S(U,V,W)</sub> (High side supplies)

V<sub>B</sub> to V<sub>S</sub> is the high side supply voltage. The high side circuit can float with respect to COM following the external high side power device emitter voltage.

Due to the low power consumption, the floating driver stage is supplied by integrated bootstrap circuit.

The under-voltage detection operates with a rising supply threshold of typical  $V_{BSUV+} = 10.41V$  and a falling threshold of  $V_{BSUV-} = 9.4V$ .

V<sub>S(U,V,W)</sub> provide a high robustness against negative voltage in respect of COM. This ensures very stable designs even under rough conditions.

### N(U, V, W) (Low side emitters)

The low side emitters are available for current measurements of each phase leg. It is recommended to keep the connection to pin COM as short as possible in order to avoid unnecessary inductive voltage drops.

### VTH (Thermistor)

A UL certified NTC is integrated in the module with one terminal of the chip connected to COM and the other to VTH. When pulled up to a rail voltage such as V<sub>DD</sub> or 3.3V by a resistor, the VTH pin provides an analog voltage signal corresponding to the temperature of the thermistor

**RFE (RCIN / Fault / Enable)**

The RFE pin combines 3 functions in one pin: RCIN or RC-network based programmable fault clear timer, fault output and enable input.

The RFE pin is normally connected to an RC network on the PCB per the schematic in Figure 5. Under normal operating conditions, R<sub>RCIN</sub> pulls the RFE pin to 3.3V, thus enabling all the functions in the IPM. The microcontroller can pull this pin low to disable the IPM functionality. This is the Enable function.

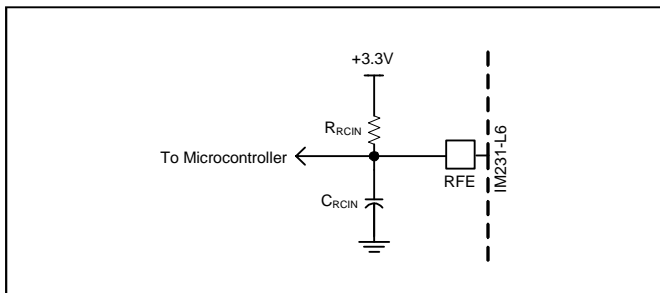

**Figure 5** Typical PCB circuit connected to the RFE pin

The Fault function allows the IPM to report a Fault condition to the microcontroller by pulling the RFE pin low in one of two situations. The first is an under-voltage condition on V<sub>DD</sub> and the second is when the ITRIP pin sees a voltage rising above V<sub>IT,TH+</sub>.

The programmable fault clear timer function provides a means of automatically re-enabling the module operation a preset amount of time (T<sub>FLT-CLR</sub>) after the fault condition has disappeared. Figure 6 shows the RFE-related circuit block diagram inside the IPM.

The length of T<sub>FLT-CLR</sub> can be determined by using the formula below.

$$V_{RFE}(t) = 3.3V * (1 - e^{-t/RC})$$

$$T_{FLT-CLR} = -R_{RCIN} * C_{RCIN} * \ln(1 - V_{IN,TH+}/3.3V)$$

For example, if R<sub>RCIN</sub> is 1.2MΩ and C<sub>RCIN</sub> is 1nF, the T<sub>FLT-CLR</sub> is about 1.7ms with V<sub>IN,TH+</sub> of 2.5V. It is also important to note that C<sub>RCIN</sub> needs to be minimized in order to make sure it is fully discharged in case of over current event.

Since the ITRIP pin has a 350ns input filter, it is appropriate to ensure that C<sub>RCIN</sub> will be discharged below V<sub>IN,TH-</sub> by the open-drain MOSFET, after 350ns. Therefore, the max C<sub>RCIN</sub> can be calculated as:

$$V_{RFE}(t) = 3.3V * e^{-t/RC} < V_{IN,TH-}$$

$$C_{RCIN} < 350ns / (- \ln (V_{IN,TH-} / 3.3V)) * R_{RFE\_ON}$$

Consider V<sub>IN,TH-</sub> of 0.8V and R<sub>RFE\_ON</sub> of 50ohm, C<sub>RCIN</sub> should be less than 4.9nF. It is also suggested to use a R<sub>RCIN</sub> of between 0.5MΩ and 2MΩ.

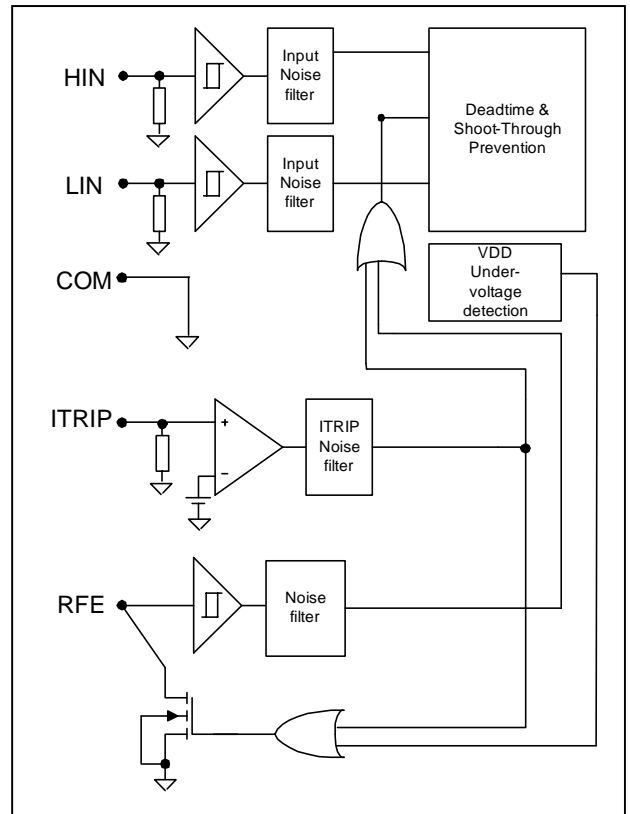

**Figure 6** RFE internal circuit structure

**V<sub>s1</sub>, V<sub>s2</sub>, V<sub>s3</sub> (High side emitter and low side collector)**

These pins are motor U, V, W input pins.

**P (Positive bus input voltage)**

The high side IGBTs are connected to the bus voltage. It is noted that the bus voltage does not exceed 450V.

Absolute Maximum Rating

### 3 Absolute Maximum Rating

#### 3.1 Module

**Table 3**

Parameter	Symbol	Conditions	Value	Units
Operating junction temperature	$T_J$	IGBT, diode, HVIC	-40 ~ 150	°C
Operating case temperature	$T_C$		-40 ~ 125	°C
Storage temperature	$T_{STG}$		-40 ~ 125	°C
Isolation test voltage	$V_{ISO}$	AC RMS, 1 minute, 60Hz	2000	V

#### 3.2 Inverter

**Table 4**

Parameter	Symbol	Conditions	Value	Units
Blocking voltage	$V_{CES}$	IGBT, diode, HVIC	600	V
DC -link supply voltage of P-N	$V_{PN}$	Applied between P and N	450	V
DC -link supply voltage (surge) of P-N	$V_{PN(surge)}$	Applied between P and N	500	V
Output current	$I_O$	$T_C = 25^\circ\text{C}$ , $T_J < 150^\circ\text{C}$	±10	A
Peak output current	$I_{O(peak)}$	$T_C = 25^\circ\text{C}$ , $T_J < 150^\circ\text{C}$ , less than 1ms	±15	A
Power dissipation per IGBT	$P_{tot}$		20	W
Short Circuit withstand time	$T_{SC}$	$T_J < 150^\circ\text{C}$ , $V_{DC} = 360\text{V}$ , $V_{GE} = 15\text{V}$	3	µs

#### 3.3 Control

**Table 5**

Parameter	Symbol	Conditions	Value	Units
Logic supply voltage	$V_{DD}$		-0.3 ~ 20	V
Input voltage	$V_{IN}$	LIN, HIN, ITRIP, RFE	-0.3 ~ 20	V
High side floating supply voltage ( $V_B$ reference to $V_S$ )	$V_{BS(U,V,W)}$		-0.3 ~ 20	V



## 4 Thermal Characteristics

**Table 6**

Parameter	Symbol	Conditions	Value			Units
			Min.	Typ.	Max.	
Single IGBT thermal resistance, junction-case	$R_{TH(J-C)}$	Low side V-phase IGBT (See Figure 6 for $T_c$ measurement point)	-	5.3	6.1	°C/W
Single diode thermal resistance, junction-case	$R_{TH(J-C)D}$	Low side V-phase diode (See Figure 6 for $T_c$ measurement point)	-	6.6	7.7	°C/W

## 5 Recommended Operating Conditions

For proper operation the device should be used within the recommended conditions. All voltages are absolute referenced to COM. The VS offset is tested with all supplies biased at 15V differential.

**Table 7**

Parameter	Symbol	Conditions	Value			Units
			Min.	Typ.	Max.	
Positive DC bus input voltage	$V_{DC}$		-	-	450	V
Low side control supply voltage	$V_{DD}$		13.5	15	16.5	V
High side floating supply voltage	$V_{BS}$		12.5	15	17.5	V
Input voltage	$V_{IN}$	LIN, HIN, ITRIP, RFE	0	-	5	V
PWM carrier frequency	$F_{PWM}$		-	20	-	kHz
Voltage between COM and N (including surge)	$V_{COM}$		-5	-	5	V
External dead time between HIN & LIN	DT		1	-	-	$\mu$ s
Input pulse width	$PW_{IN(ON)}$ $PW_{IN(OFF)}$		1	-	-	$\mu$ s

## 6 Static Parameters

### 6.1 Inverter

$V_{BIAS}(V_{DD}, V_{BS(U,V,W)})=15V, T_J=25^{\circ}C$  unless otherwise specified

**Table 8**

Parameter	Symbol	Conditions	Value			Units
			Min.	Typ.	Max.	
Collector-Emitter saturation voltage	$V_{CE(ON)}$	$I_C = 5A$	-	1.5	1.9	V
		$I_C = 5A, T_J = 150^{\circ}C$	-	1.7	-	V
Collector-Emitter leakage current	$I_{CES}$	$V_{IN} = 0V, V_{CE} = 600V$	-	10	80	$\mu A$
		$V_{IN} = 0V, V_{CE} = 600V, T_J=150^{\circ}C$	-	80	-	$\mu A$
Diode forward voltage drop	$V_F$	$I_C = 5A$	-	1.7	2.2	V
		$I_C = 5A, T_J = 150^{\circ}C$	-	1.6	-	V

### 6.2 Control

$V_{BIAS}(V_{DD}, V_{BS(U,V,W)})=15V, T_J=25^{\circ}C$ , unless otherwise specified. The VIN parameters are referenced to COM and are applicable to all six channels

**Table 9**

Parameter	Symbol	Conditions	Value			Units
			Min.	Typ.	Max.	
Logic "1" input voltage	$V_{IN,TH+}$	LIN, HIN, RFE	2.5	-	-	V
Logic "0" input voltage	$V_{IN,TH-}$	LIN, HIN, RFE	-	-	0.8	V
$V_{DD}/V_{BS}$ supply under voltage, positive going threshold	$V_{DD,UV+}, V_{BS,UV+}$		9.6	10.4	11.2	V
$V_{DD}/V_{BS}$ supply under voltage, negative going threshold	$V_{DD,UV-}, V_{BS,UV-}$		8.6	9.4	10.2	V
$V_{DD}/V_{BS}$ supply under voltage lock-out hysteresis	$V_{DDUVH}, V_{BSUVH}$		-	1	-	V
Quiescent $V_{BS}$ supply current	$I_{QBS}$		-	-	150	$\mu A$
Quiescent $V_{DD}$ supply current	$I_{QDD}$		-	-	3.2	mA
Offset supply leakage current	$I_{LK}$	$V_S = 600V$	-	-	50	$\mu A$
Input bias current for LIN, HIN	$I_{IN+}$	$V_{IN} = 3.3V$	-	825	1110	$\mu A$
Input bias current for RFE	$I_{IN,RFE+}$	$V_{REF} = 3.3V$	-	0	1	$\mu A$
Input bias current for ITRIP	$I_{TRIP+}$	$V_{ITRIP} = 3.3V$	-	4	16	$\mu A$
ITRIP threshold voltage	$V_{ITRIP}$		0.44	0.49	0.54	V

Static Parameters

Parameter	Symbol	Conditions	Value			Units
			Min.	Typ.	Max.	
ITRIP input hysteresis	$V_{ITRIP,HYS}$		-	0.07	-	V
Bootstrap resistance	$R_{BS}$		-	200	-	$\Omega$
RFE low on resistance	$R_{RFE}$		-	50	100	$\Omega$

## 7 Dynamic Parameters

### 7.1 Inverter

$V_{BIAS}(V_{DD}, V_{BS(U,V,W)})=15V$ ,  $T_J=25^{\circ}C$ , unless otherwise specified.

**Table 10**

Parameter	Symbol	Conditions	Value			Units
			Min.	Typ.	Max.	
Input to output turn-on propagation delay	$T_{ON}$	$I_C = 5A, V_{DC} = 300V$	-	-	1.15	$\mu s$
Input to output turn-off propagation delay	$T_{OFF}$	$I_C = 5A, V_{DC} = 300V$	-	-	1.15	$\mu s$
RFE low to six switch turn-off propagation delay	$T_{EN}$	$V_{RFE} = 5V \text{ to } 0V$	-	-	1.35	$\mu s$
ITRIP to six switch turn-off propagation delay	$T_{ITRIP}$	$I_C = 5A, V_{DC} = 300V$	-	-	1.5	$\mu s$
IGBT turn-on energy	$E_{ON}$	$V_{DC} = 300V, I_C = 5A,$ $T_J = 25^{\circ}C$ $150^{\circ}C$	-	170 250	-	$\mu J$
IGBT turn-off energy	$E_{OFF}$	$V_{DC} = 300V, I_C = 5A,$ $T_J = 25^{\circ}C$ $150^{\circ}C$	-	70 110	-	$\mu J$
Diode reverse recovery energy	$E_{REC}$	$V_{DC} = 300V, I_C = 5A,$ $T_J = 25^{\circ}C$ $150^{\circ}C$	-	20 40	-	$\mu J$
Reverse Bias Safe Operating Area	RBSOA	$T_J = 150^{\circ}C, I_C = 20A, V_P = 600V,$ $V_{DC} = 450V, V_{DD} = +15V \text{ to } 0V$	FULL SQUARE			

### 7.2 Control

$V_{BIAS}(V_{DD}, V_{BS(U,V,W)})=15V$ ,  $T_J=25^{\circ}C$ , unless otherwise specified.

**Table 11**

Parameter	Symbol	Conditions	Value			Units
			Min.	Typ.	Max.	
Input filter time (HIN, LIN, ITRIP)	$T_{FILIN}$	$V_{IN} = 0 \text{ or } V_{IN} = 5V$	-	350	-	ns
Input filter time (RFE)	$T_{FILRFE}$	$V_{RFE} = 0 \text{ or } V_{RFE} = 5V$	100	200	-	ns
ITRIP to Fault propagation delay	$T_{FLT}$	$V_{IN} = 0 \text{ or } V_{IN} = 5V, V_{ITRIP} = 5V$	400	600	800	ns
Internal injected dead time	$T_{DT}$	$V_{IN} = 0 \text{ or } V_{IN} = 5V$	190	275	420	ns
Matching propagation delay time (On & Off) all channels	$M_T$	External dead time > 420ns	-	-	50	ns

## 8 Thermistor Characteristics

Table 12

Parameter	Symbol	Conditions	Value			Units
			Min.	Typ.	Max.	
Resistance	$R_{25}$	$T = 25^{\circ}\text{C}$ , $\pm 5\%$ tolerance	44.65	47	49.35	$\text{k}\Omega$
Resistance	$R_{125}$	$T = 125^{\circ}\text{C}$	1.27	1.41	1.56	$\text{k}\Omega$
B-constant	B	$25\text{-}50^{\circ}\text{C}$ , $R_2 = R_1 e^{[B(1/T_2 - 1/T_1)]}$	3989	4050	4111	K
Temperature Range			-40	-	125	$^{\circ}\text{C}$

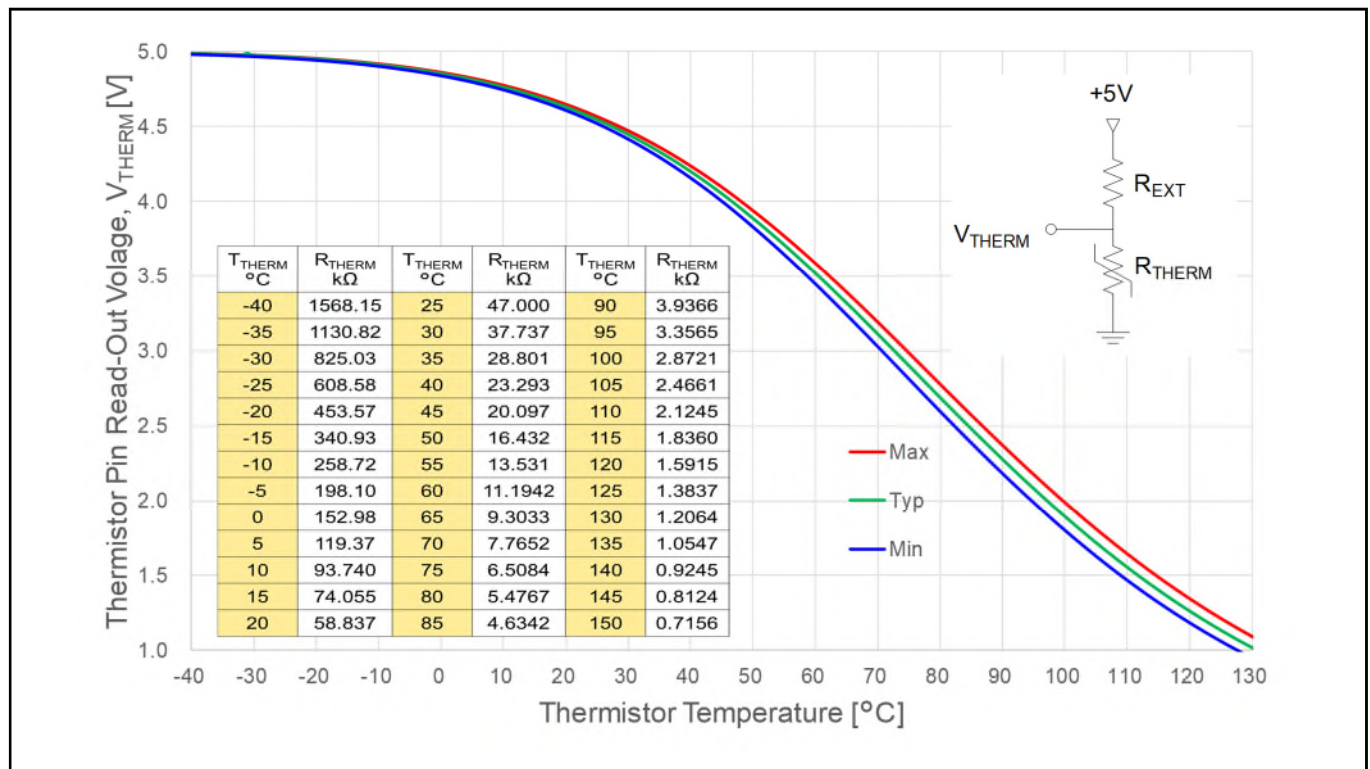
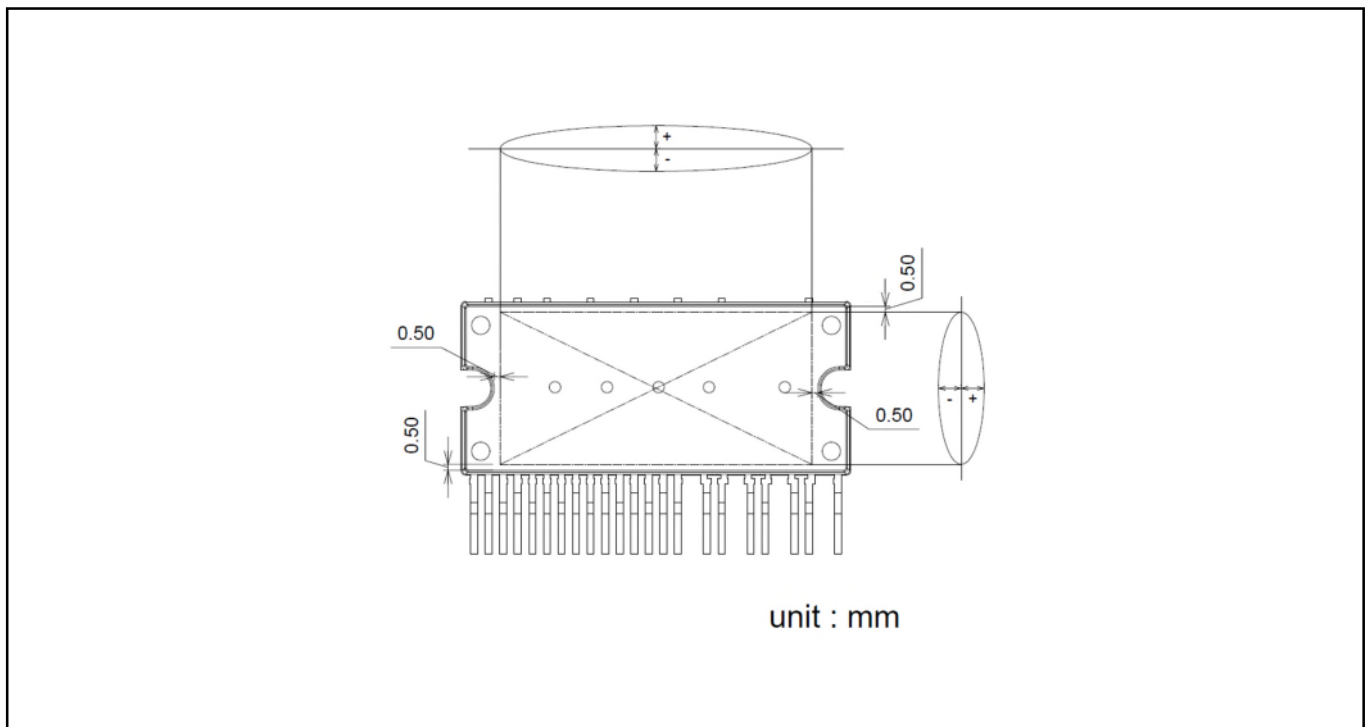

Figure 7 Thermistor readout vs. temperature (with 4.7k $\Omega$   $R_{\text{EXT}}$  pull-up resistor) and typical thermistor resistance values vs. temperature table (For more details, please refer to the application note ‘AN2018-13 CIPOS™ IM393-XX IPM technical description\_1R0\_final’)

## 9 Mechanical Characteristics and Ratings

**Table 13**

Parameter	Symbol	Conditions	Value			Units
			Min.	Typ.	Max.	
Thermal resistance, case-heatsink	$R_{TH(C-S)}$	Flat, greased surface. Heatsink compound thermal conductivity 1W/mK	-	0.25	-	°C/W
Comparative Tracking Index	CTI		600	-	-	V
Curvature of module backside	BKC		0	-	150	μm
Mounting torque	T	M3 screw and washer	0.6	0.7	0.8	Nm
Weight	W		-	5.7	-	g



**Figure 8 Backside curvature measurement position**

## 10 Qualification Information

**Table 14**

<b>UL Certified</b>	File Number : E314539	
<b>RoHS Compliant</b>	Yes	
<b>ESD</b>	Human body model class	2
	Charged device model class	C2a



## 11 Diagram & Tables

### 11.1 Tc Measurement Point

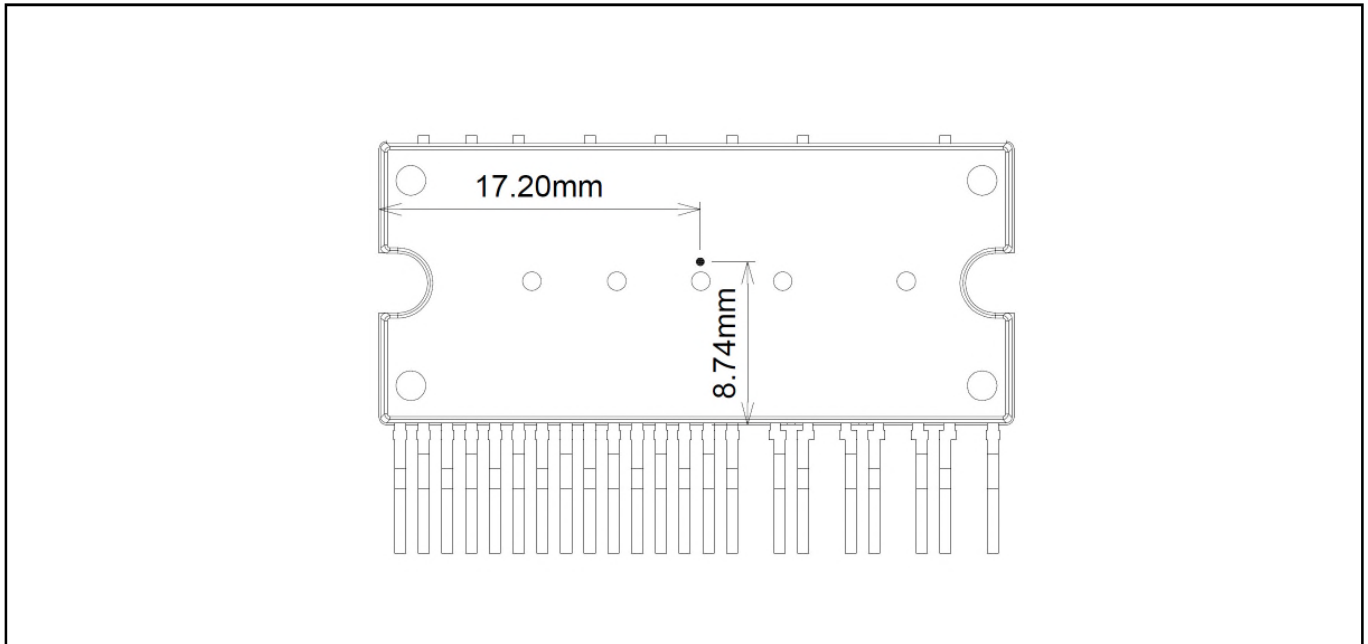

Figure 9 TC measurement point

### 11.2 Input-Output Logic Table

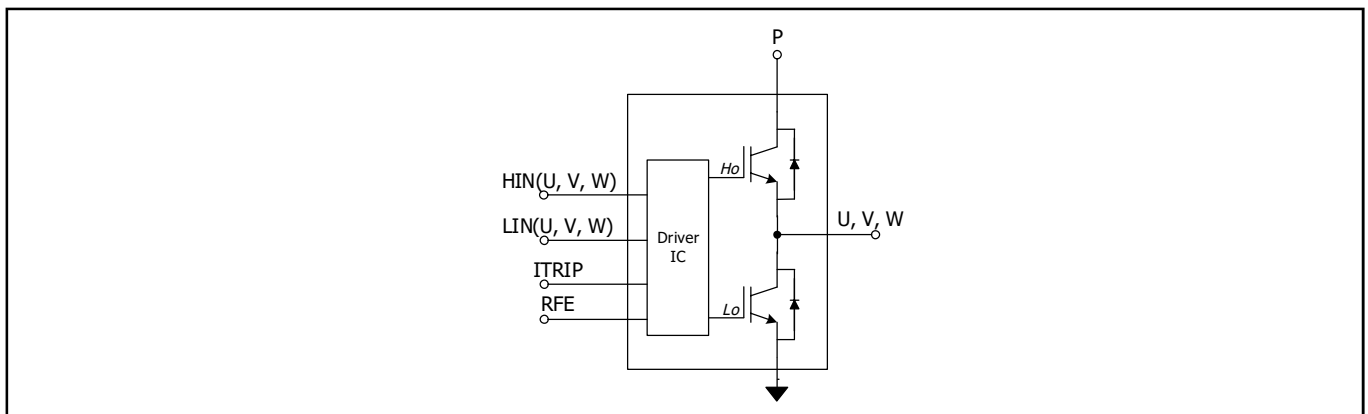

Figure 10 Module block diagram

Table 15 Input-output logic level table

RFE	ITRIP	HIN(U,V,W)	LIN(U,V,W)	U,V,W
1	0	1	0	V <sub>DC</sub>
1	0	0	1	0
1	0	0	0	Off*
1	0	1	1	Off*
1	1	X	X	Off*
0	X	X	X	Off*

\* Voltage depends on direction of phase current

### 11.3 Switching Time Definitions

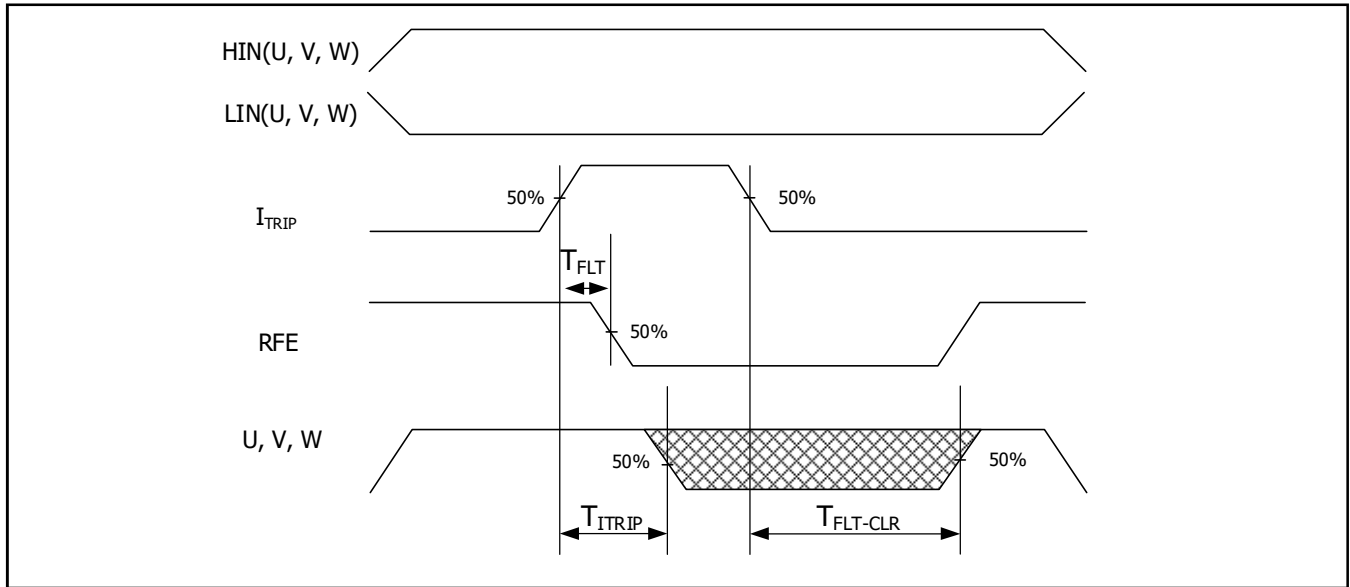

Figure 11 ITRIP time waveform

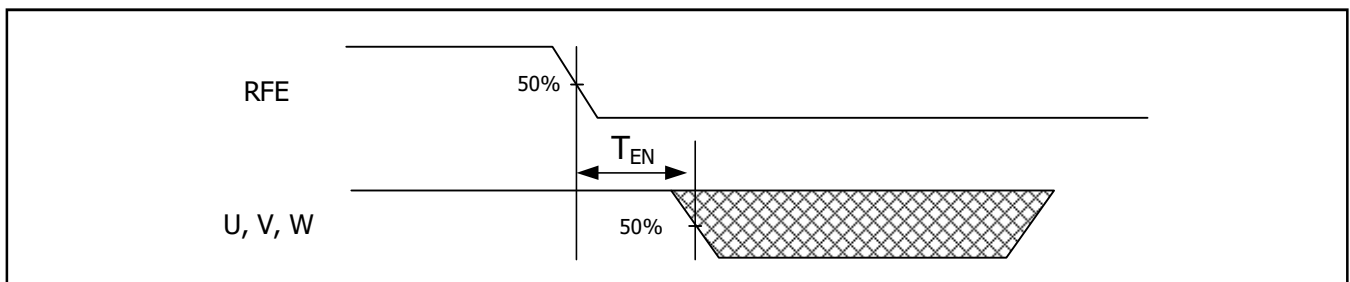

Figure 12 Output disable timing diagram

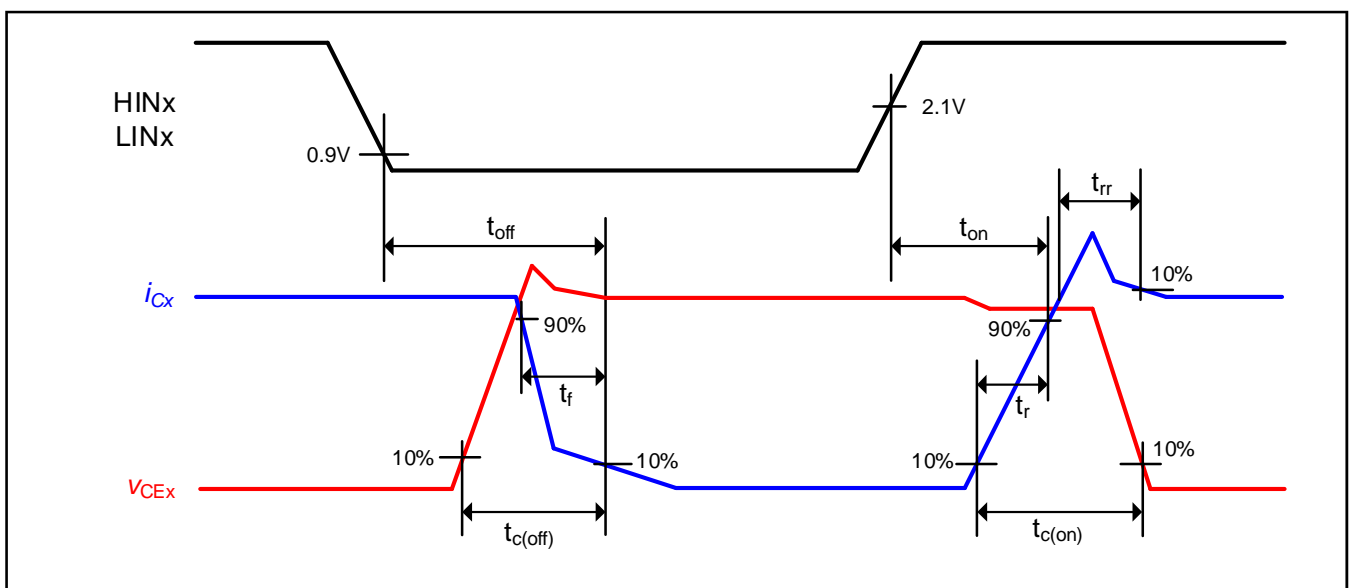
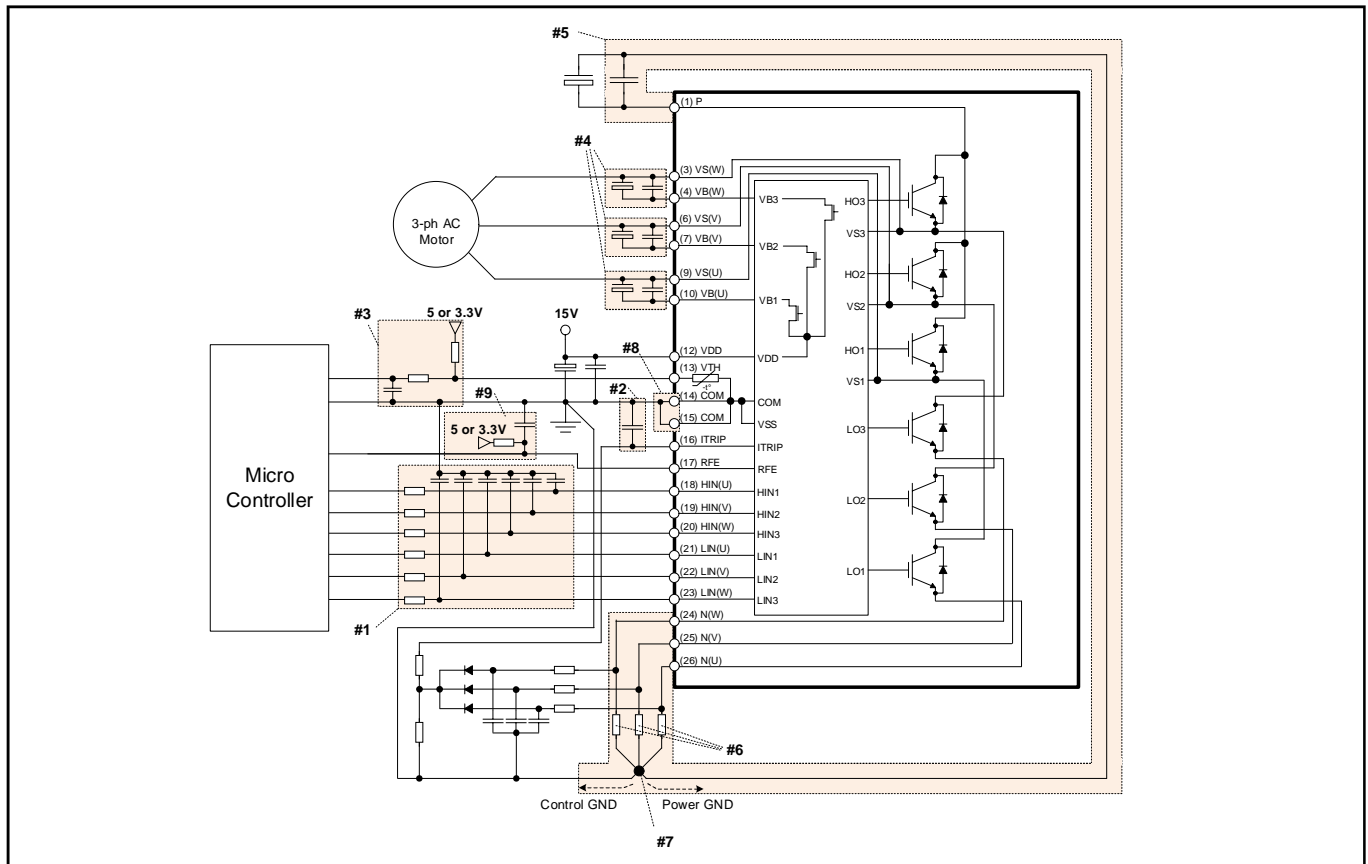

Figure 13 Switching times definition

## 12 Application Guide

### 12.1 Typical Application Schematic



**Figure 14** Typical application connection

1. Input circuit
  - RC filter can be used to reduce input signal noise (100Ω, 1nF)
  - The capacitors should be located close to CIPOS™ Tiny (to COM terminal especially).
2. Itrip circuit
  - To prevent a mis operation of protection function, RC filter is recommended
  - The capacitor must be located close to Itrip and COM terminals.
3. VTH circuit
  - This terminal should be pulled up to the bias voltage of 5V/3.3V through a proper resistor to define suitable voltage for temperature monitoring.
  - It is recommended that RC filter is placed close to the controller
4. VB-VS circuit
  - Capacitors for high side floating supply voltage should be placed close to VB and VS terminals.
  - Additional high frequency capacitors, typically 0.1μF, are strongly recommended.
  - Overlap of pattern to motor and pattern to bootstrap capacitors should be minimized.
5. Snubber capacitor
  - The wiring among CIPOS™ Tiny, snubber capacitor and shunt resistors should be short as possible.
6. Shunt resistor
  - SMD type shunt resistors are strongly recommended to minimize its internal stray inductance.
7. Ground pattern
  - Pattern overlap of power ground and signal ground should be minimized. The patterns should be connected at the common end of shunt resistors only for the same potential.
8. COM pattern
  - Both of the COM terminals should be connected together.
9. RFE circuit
  - To setup R and C parameter for fault clear time, please refer to Figure 5.
  - This R is also mandatory for fault out reporting function because it is open drain structure.

## 12.2 Performance Charts

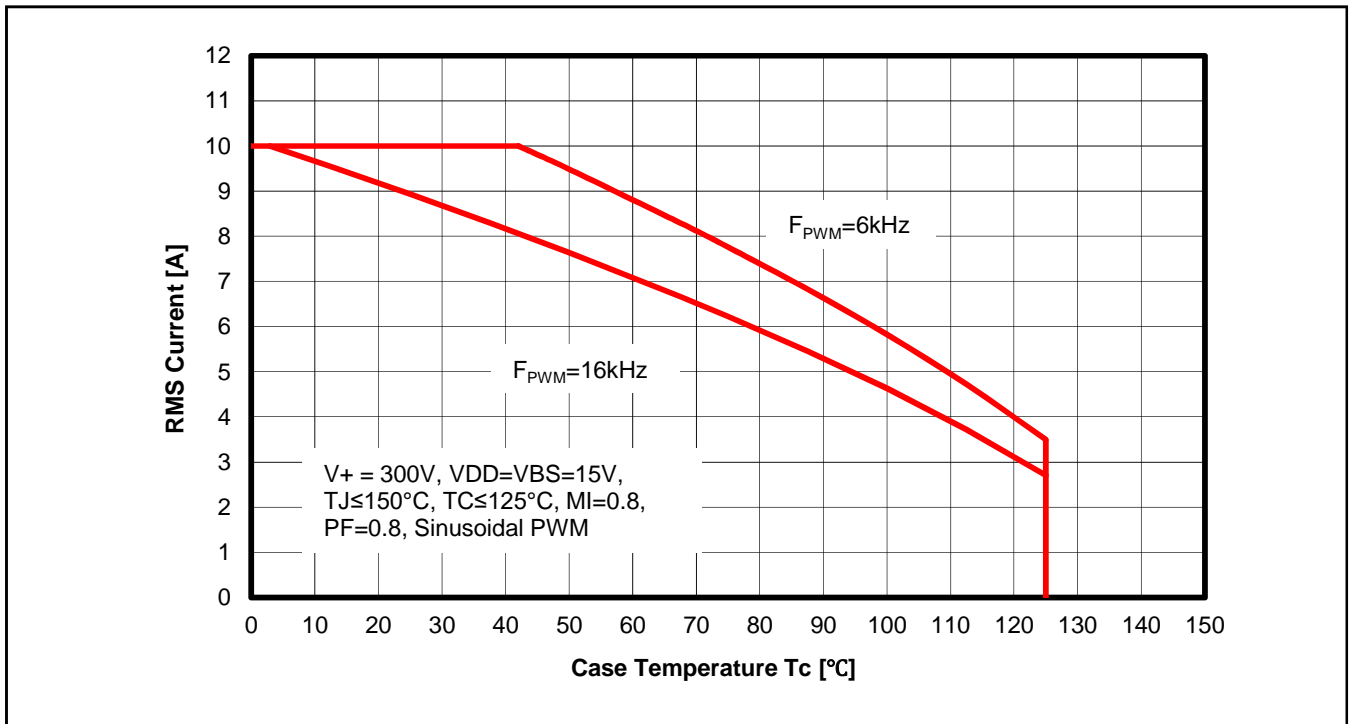

**Figure 15** Maximum operating current SOA

1. This maximum operating current SOA is just one of example based on typical characteristics for this product. It can be change by each user’s actual operating conditions.

## 12.3 Tj vs. Tth

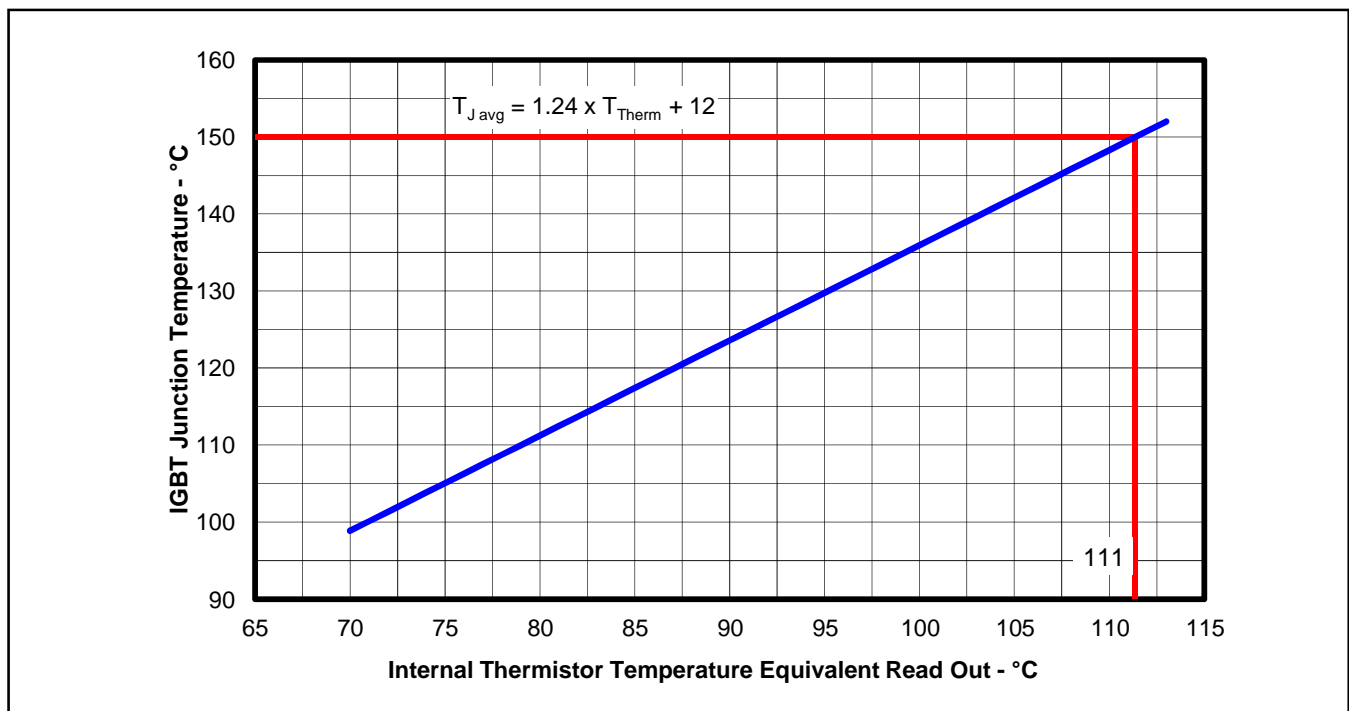

**Figure 16** Typical Tj vs Tth correlation, sinusoidal modulation,  $V_{DC}=300V$ ,  $I_{phase}=5Arms$ ,  $f_{sw}=16kHz$ ,  $f_{mod}=50Hz$ ,  $MI=0.8$ ,  $PF=0.6$

## 12.4 -V<sub>s</sub> Immunity

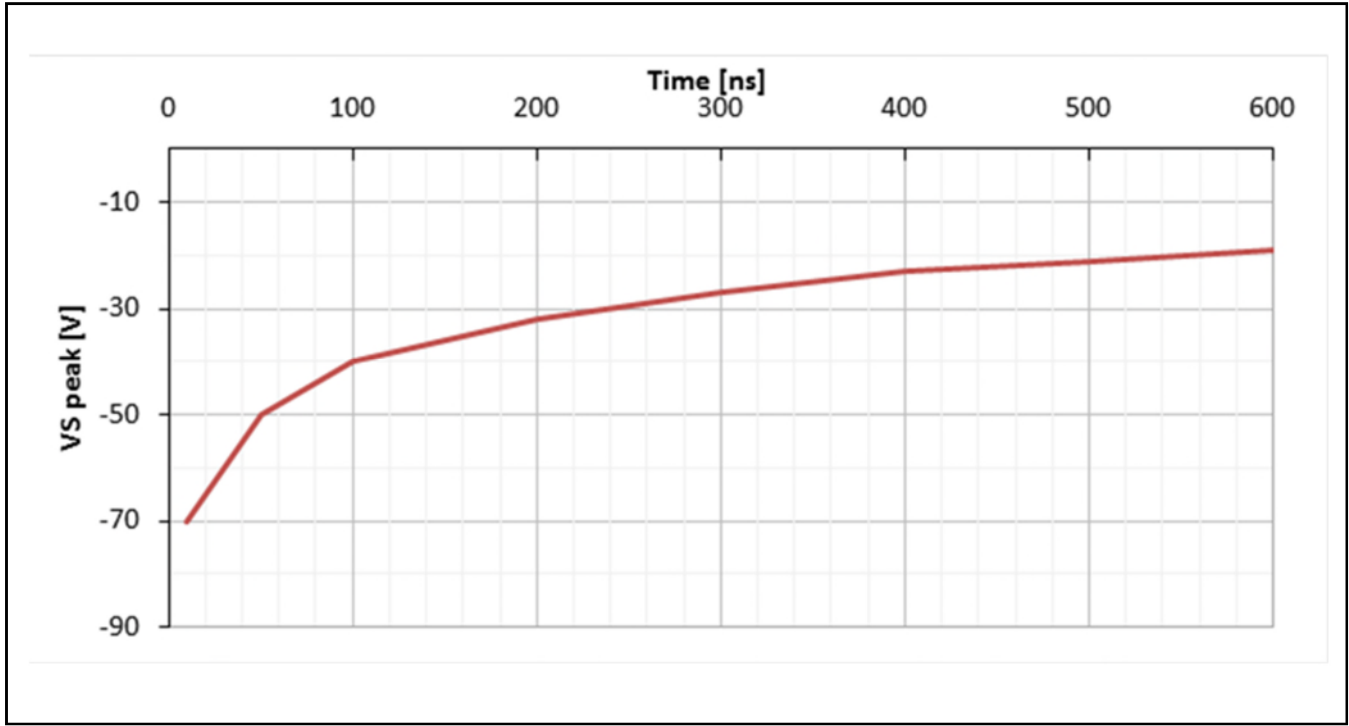

Figure 17 Negative transient Vs SOA for integrated gate driver



---

**Revision History**

**Revision History**

**Major changes since the last revision**

<b>Page or Reference</b>	<b>Revision</b>	<b>Date</b>	<b>Description of changes</b>
Page 16	V2.1	2022-08-12	ESD class changed

## Trademarks

All referenced product or service names and trademarks are the property of their respective owners.

**Edition 2022-08-12**  
**Published by**  
**Infineon Technologies AG**  
**81726 Munich, Germany**

**© 2022 Infineon Technologies AG.**  
**All Rights Reserved.**

**Do you have a question about this document?**

**Email: [erratum@infineon.com](mailto:erratum@infineon.com)**

**Document reference**  
**ifx1**

## IMPORTANT NOTICE

The information given in this document shall in no event be regarded as a guarantee of conditions or characteristics ("Beschaffungsgarantie").

With respect to any examples, hints or any typical values stated herein and/or any information regarding the application of the product, Infineon Technologies hereby disclaims any and all warranties and liabilities of any kind, including without limitation warranties of non-infringement of intellectual property rights of any third party.

In addition, any information given in this document is subject to customer's compliance with its obligations stated in this document and any applicable legal requirements, norms and standards concerning customer's products and any use of the product of Infineon Technologies in customer's applications.

The data contained in this document is exclusively intended for technically trained staff. It is the responsibility of customer's technical departments to evaluate the suitability of the product for the intended application and the completeness of the product information given in this document with respect to such application.

For further information on the product, technology, delivery terms and conditions and prices please contact your nearest Infineon Technologies office ([www.infineon.com](http://www.infineon.com)).

Please note that this product is not qualified according to the AEC Q100 or AEC Q101 documents of the Automotive Electronics Council.

## WARNINGS

Due to technical requirements products may contain dangerous substances. For information on the types in question please contact your nearest Infineon Technologies office.

Except as otherwise explicitly approved by Infineon Technologies in a written document signed by authorized representatives of Infineon Technologies, Infineon Technologies' products may not be used in any applications where a failure of the product or any consequences of the use thereof can reasonably be expected to result in personal injury.