

| Main technical indicators(主要技术指标) |  |
|-----------------------------------|--|
| 1.Mating (插拔次数)                   | 5000   |
| 2.Working Temperature (温度)        | -55~+150 °C  |
| 3.IP Rating (防护级别)                | IP 50  |
| 4.Diameter of socket end(插合端直径)   | φ0.5   |
| 5.Testing Voltage (测试电压)          | 950V   |
| 6.Working Voltage (工作电压)          | 1300V  |
| 7.Rated Current (额定电流)            | 2.0A   |
| 8.Shell material(壳体材质)            | Brass (chromium plating) shell and chuck nut/( nickel plating) pin sleeve and middleware/黄铜（镀铬）外壳和夹头螺母/（镀镍）插销套和中间件 |
| 9.Pin Material(插针材料)              | Copper alloy gold plating(铜合金镀金)   |
| 10.Insulator material(绝缘体材质)      | L:PPS P:PEEK   |

| Sum up(总结)                  |   |
|-----------------------------|---|
| Series(系列)                  | B   |
| Shell style/model (外壳样式/型号) | TGG: Straight plug, cable collet and nut for fitting a bend relief直塞、电缆夹头和螺母，用于安装弯曲凸起 |
| Button (按键)                 | A button(一个按键)  |
| Termination type (终止类型)     | Male solder(公焊锡)  |
| Line diameter awg(线材直径)     | 34-28AWG  |
| Cable diameterφ (电缆直径)      | φ1.4-9.9MM  |
| Matching parts(配件)          | ZGG.2B.P26.CXL  |

| Location pin combination(定位销组合) |                                   |           |                         |
|---------------------------------|-----------------------------------|-----------|-------------------------|
| (编号) Number                     | Number of positioning pins(定位销数量) | Angle(角度) | Series(系列)--2B          |
| G                               | One(1)                            |           | (Zero degrees)0°        |
| A                               | Two(2)                            | A         | Thirty degrees(30°)     |
| B                               | Two(2)                            |           | Forty-five degrees(45°) |
| C                               | Two(2)                            |           | Sixty degrees(60°)      |
| D                               | Two(2)                            | γ         | 95 degrees (95°)        |
| E                               | Two(2)                            | β         | 120 degrees(120°)       |
| F                               | Two(2)                            |           | 145 degrees(145°)       |
| J                               | Two(2)                            | A         | 37.5degrees(37.5°)      |
| K                               | Two(2)                            |           | 52.5degrees(52.5°)      |
| L                               | Two(2)                            | γ         | Seventy degrees(70°)    |

|        | A      | B      | C√     | ANGLE   |       |
|--------|--------|--------|--------|---------|-------|
| 5-10   | ±0.02  | ±0.05  | ±0.1   | 0°-30°  | ±0.1° |
| 50-100 | ±0.1   | ±0.15  | ±0.2   | 61°-90° | ±0.5° |
| 50-100 | ±0.15  | ±0.2   | ±0.25  |         |       |
| 100-   | ±0.15% | ±0.20% | ±0.25% |         |       |

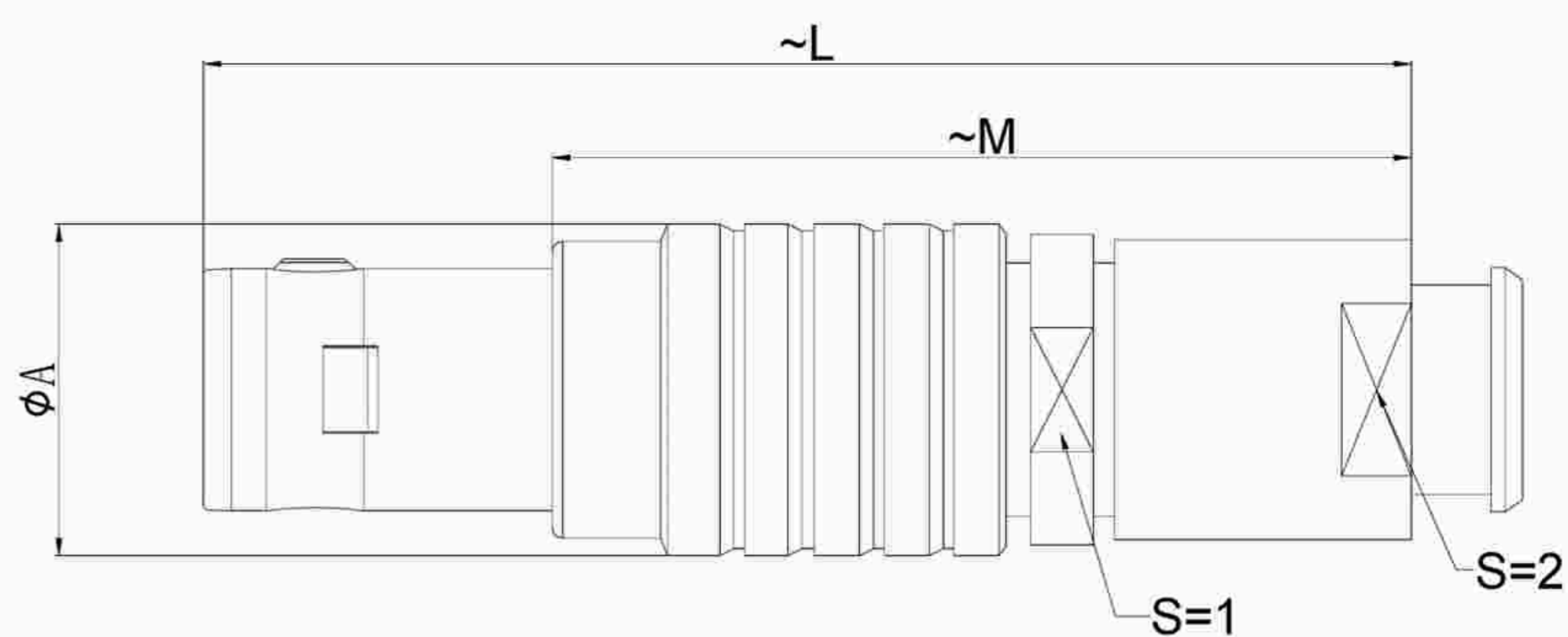

|    | A      | L      | M      | S1    | S2     |
|----|--------|--------|--------|-------|--------|
| MM | φ15    | 49     | 37     | 13.0  | 12     |
| in | 0.5906 | 1.9292 | 1.4567 | 0.512 | 0.4725 |



Welded surface  
(焊接面)

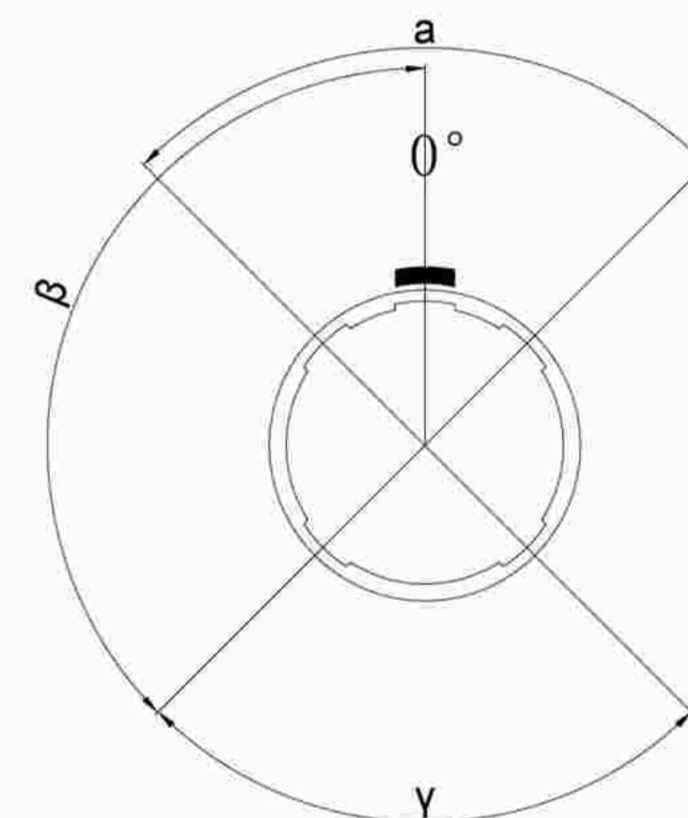

Positive view  
(正视图)

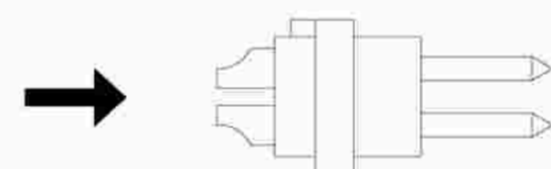

Solder core  
(焊接型公胶芯)

TG G. 2B. P26.C X A D 62 H

|   |                            |
|---|----------------------------|
| Model(型号)   | TG G. 2B. P26.C X A D 62 H |
| Positioning pin(定位销)  |                            |
| Series(系列)  |                            |
| Needle core configuration(针芯配置)                                 |                            |
| Outer casing(外壳)  |                            |
| Insulator(绝缘体)  |                            |
| Needle core(针芯)   |                            |
| Type of CXamp(线夹类型)   |                            |
| Cable diameter(电缆直径)  |                            |
| SH means a sheath type, not a cover type.<br>(H表示护套型，不表示为不带护套型) |                            |

DESIGNED(设计)  
广东星坤科技股份有限公司  
CHECKED(校对)

APPROVED(审核)  
日期

REVISIONS

文件工程章

www.helloxkb.com www.helloxkb.cn

|          |  |
|----------|--|
| DATE(日期) |  |
| DATE(日期) |  |
| DATE(日期) |  |

|               |          |
|---------------|----------|
| SCALE(比额)     | N/A(不适用) |
| VIEW(视图)      |          |
| UNIT(单位)      | MM       |
| MATERIAL (材料) |          |

|                          |                |              |
|--------------------------|----------------|--------------|
| MODEL TYPE               |                |              |
| 型号类型: TGG.2B.P26.CXAD62H |                |              |
| PART NO.                 | 2B26-core plug |              |
| 名称:                      | 2B26芯插头        |              |
| DWG NO.:                 |                |              |
| WEIGHT(重量)               | SHEET(表)       | REVISION(修订) |
|                          | 1/1            | A0           |