

Jul.1.2024 Copyright 2024 HIROSE ELECTRIC CO., LTD. All Rights Reserved.
 In case of consideration for using Automotive equipment / device which demand high reliability, kindly contact our sales window correspondents.

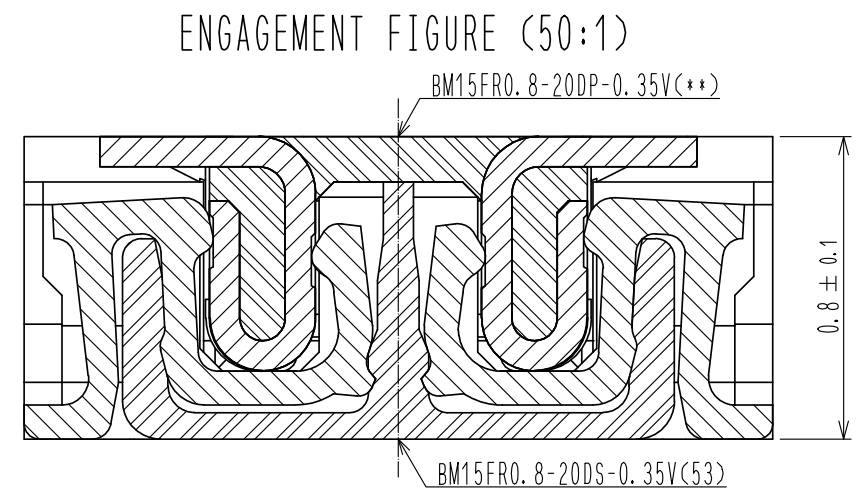
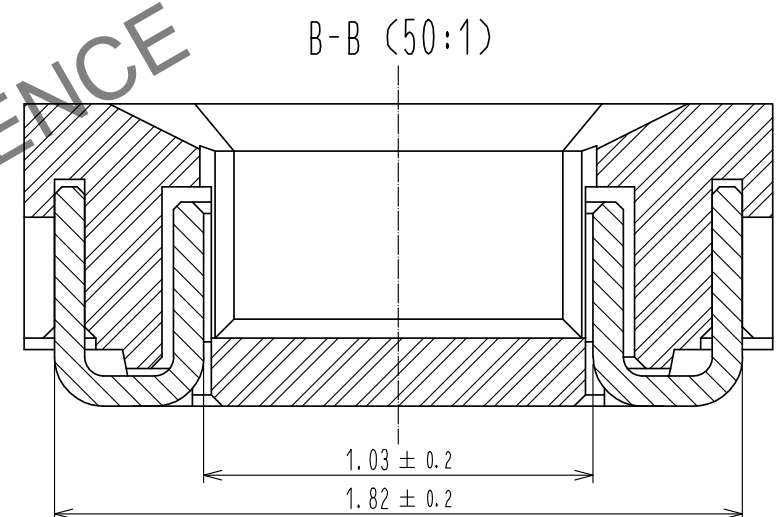
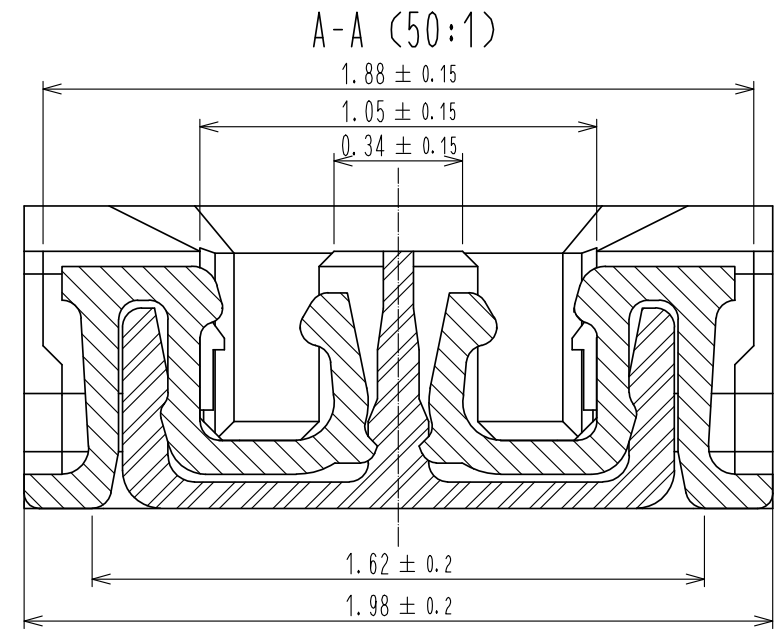
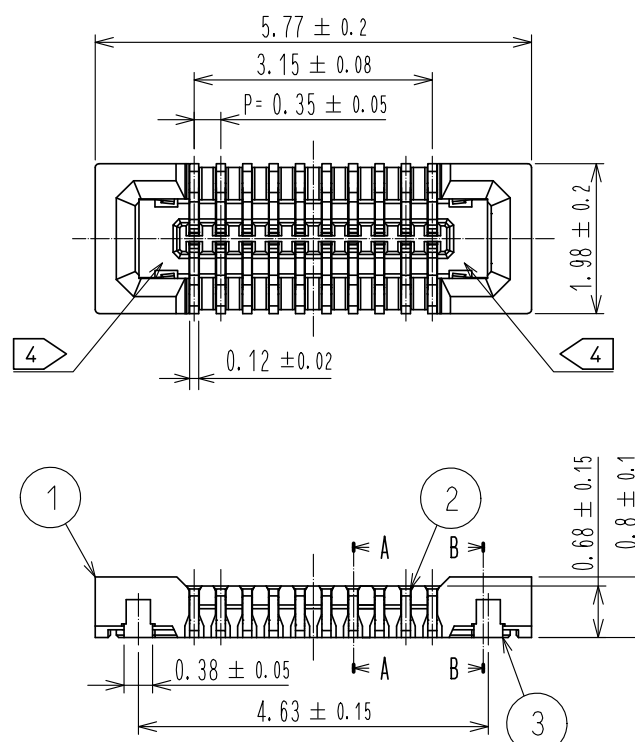

NOTE) 1 . ALL LEAD CO-PLANARITY SHALL BE 0.08mm MAX
 2 CONTACT PLATING SPECIFICATIONS.
 CONTACT AREA : GOLD 0.05 μm MIN
 SMT LEAD : GOLD 0.05 μm MIN
 UNDERPLATING : NICKEL 1 μm MIN
 (SURFACE : SEALING)
 3 REINFORCED METAL FITTINGS LOCK
 SMT LEAD : GOLD 0.05 μm MIN
 UNDERPLATING : NICKEL 1 μm MIN
 (SURFACE : SEALING)
 4 CAV NO. AND HRS MARK MAY BE INDICATED IN APPROX POSITION SHOWN.

HRS DRAWING FOR REFERENCE

4	PS	CLEAR (ENBOSSED CARRIER TAPE)			
3	PHOSPHOR BRONZE	3	7	PS	CLEAR (REINFORCEMENT COLLAR)
2	PHOSPHOR BRONZE	2	6	PS	BLACK (PLASTIC REEL)
1	LCP	UL94 V-0, BLACK	5	POLYESTER	CLEAR (COVER TAPE)
NO.	MATERIAL	FINISH . REMARKS	NO.	MATERIAL	FINISH . REMARKS
UNITS	mm	SCALE	10 : 1	COUNT	DESCRIPTION OF REVISIONS
					DESIGNED
					CHECKED
					DATE
APPROVED : MO. ISHIDA		16.01.08	DRAWING NO. EDC-355887-53-01		
CHECKED : TS. MIYAZAKI		16.01.08	PART NO. BM15FR0.8-20DS-0.35V(53)		
DESIGNED : SH. HOSODA		16.01.07	CODE NO. CL673-1227-0-53		
DRAWN : KR. AJITO		16.01.07			

Jul.1.2024 Copyright 2024 HIROSE ELECTRIC CO., LTD. All Rights Reserved.
 In case of consideration for using Automotive equipment / device which demand high reliability, kindly contact our sales window correspondents.

◆ RECOMMENDED PCB LAYOUT

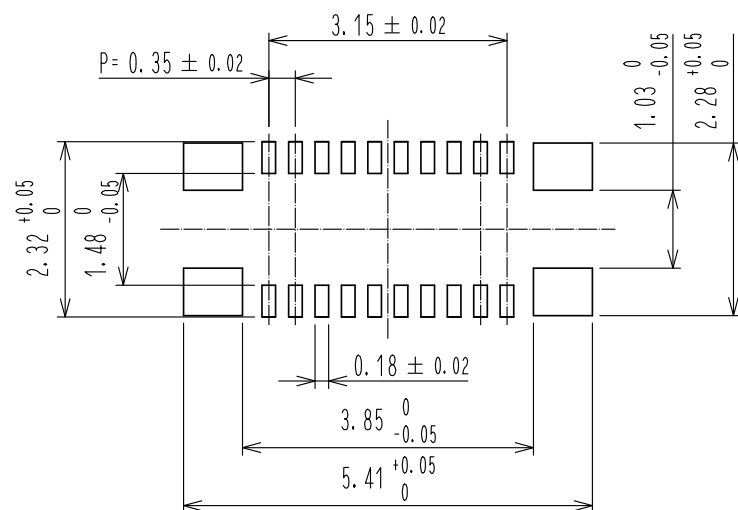

◆ RECOMMENDED METAL MASK DIMENSIONS

METAL MASK THICKNESS : 100 μm

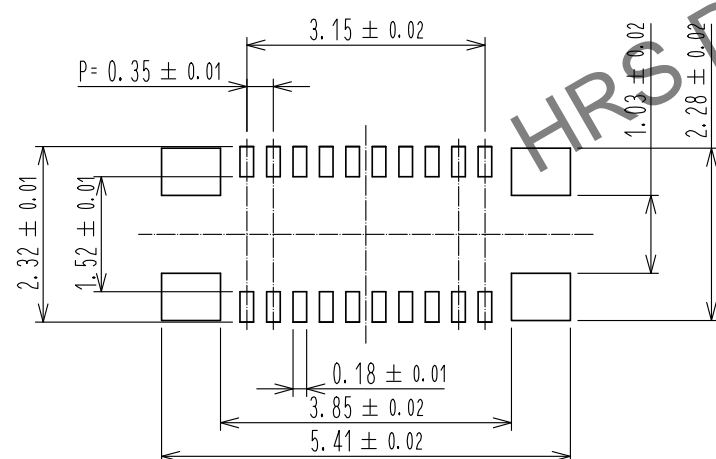

⇒ RECOMMENDED REFLOW TEMPERATURE PROFILE USING LEAD-FREE SOLDER PASTE.

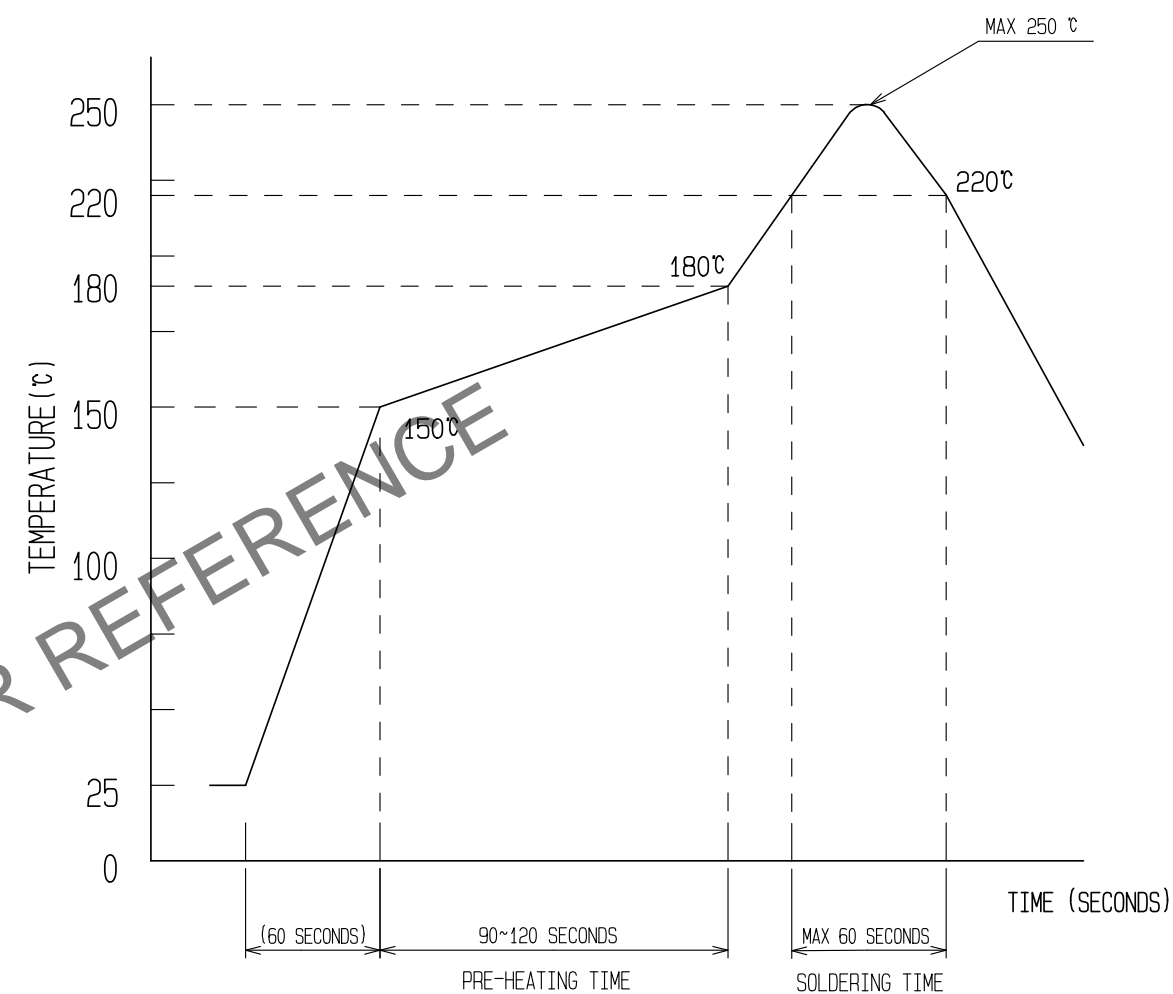

- REFLOW METHOD: IR REFLOW
 NUMBER OF REFLOW CYCLES: 2 CYCLES MAX.
- 1) REFLOW TIME
 DURATION ABOVE 220°C, 60 SEC. MAX.
 (PEAK TEMPERATURE: 250°C MAX)
 - 2) PRE-HEAT TIME
 PRE-HEAT TEMPERATURE(MIN): 150°C
 PRE-HEAT TEMPERATURE(MAX): 180°C
 PRE-HEAT TIME: 90-120 sec.

⇒ THIS TEMPERATURE PROFILE IS PER THE CONDITIONS SHOWN ABOVE. ADDITIONAL FACTORS, SUCH AS SOLDER PASTE TYPE, PCB SIZE AND OTHER MOUNTED COMPONENTS COULD AFFECT THE PROFILE, THEREFORE, A THOROUGH EVALUATION OF MOUNTING CONDITION IS REQUIRED PRIOR TO PRODUCTION. TEMPERATURE IS MEASURED AT CONTACT LEAD.

HRS	DRAWING NO.	EDC-355887-53-01
	PART NO.	BM15FR0.8-20DS-0.35V(53)
	CODE NO.	CL673-1227-0-53

Jul.1.2024 Copyright 2024 HIROSE ELECTRIC CO., LTD. All Rights Reserved.
 In case of consideration for using Automotive equipment / device which demand high reliability, kindly contact our sales window correspondents.

EMBOSED CARRIER TAPE PACKAGING (5:1)

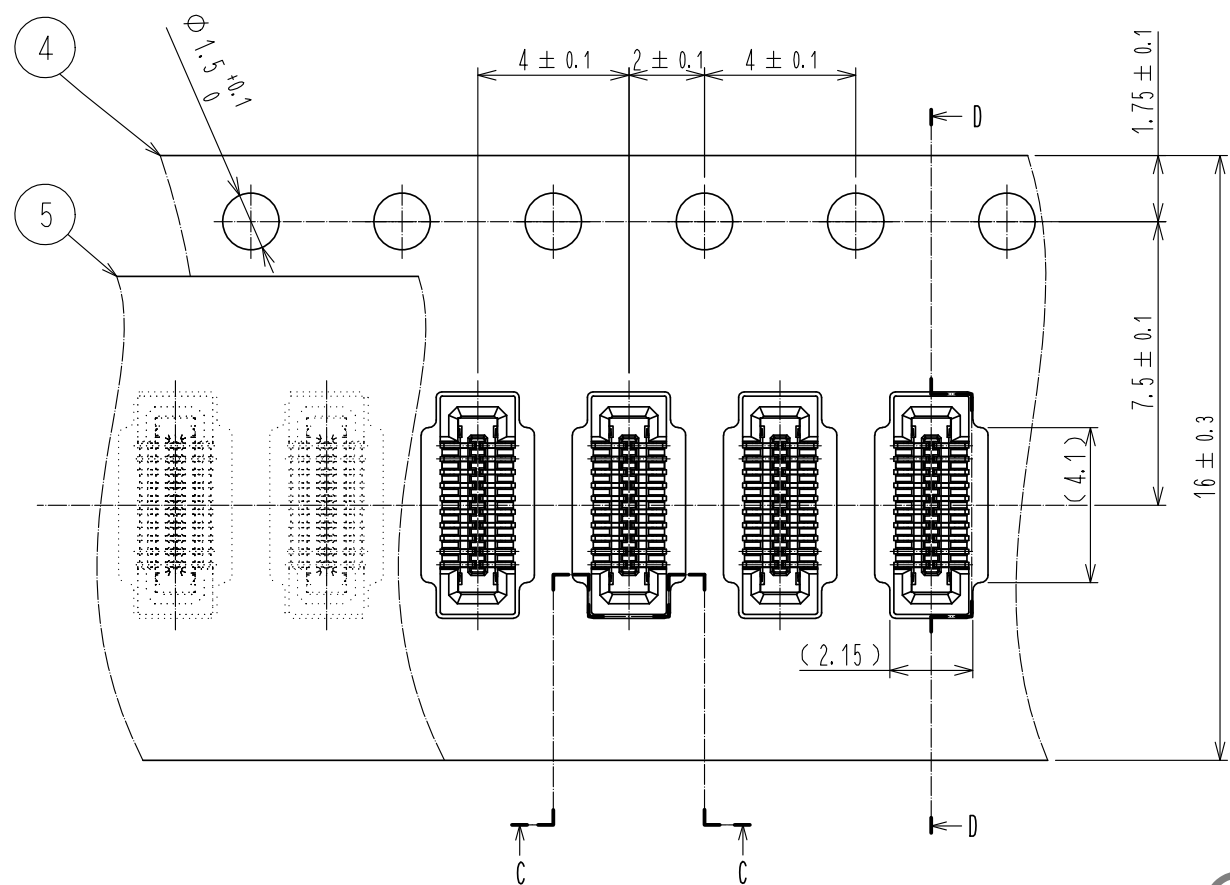

DIRECTION OF UNREELING
 →

C-C (5:1)

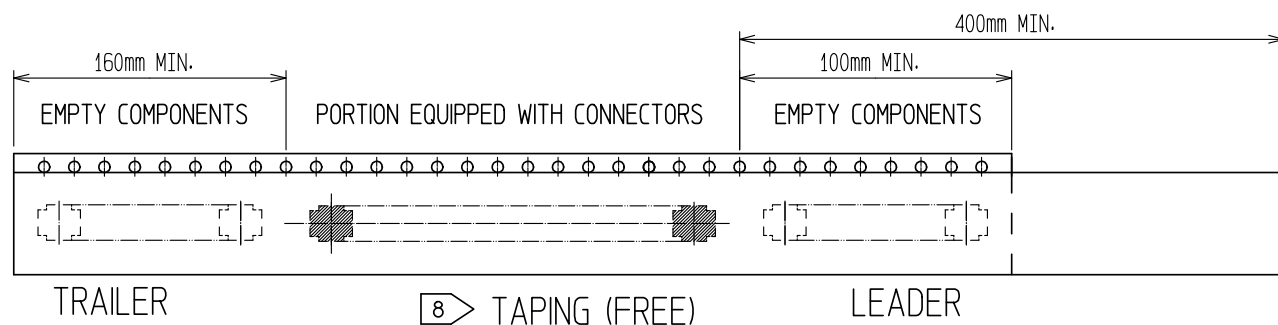
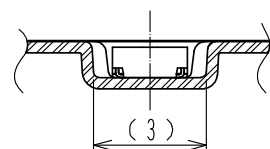

8 TAPING (FREE)

D-D (5:1)

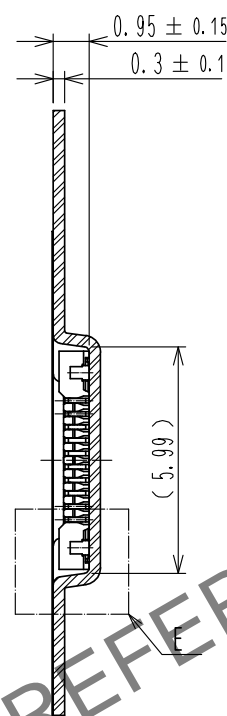

E(10:1)

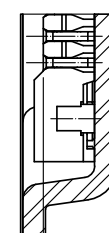

STYLE AND DIMENTION OF REEL (FREE)

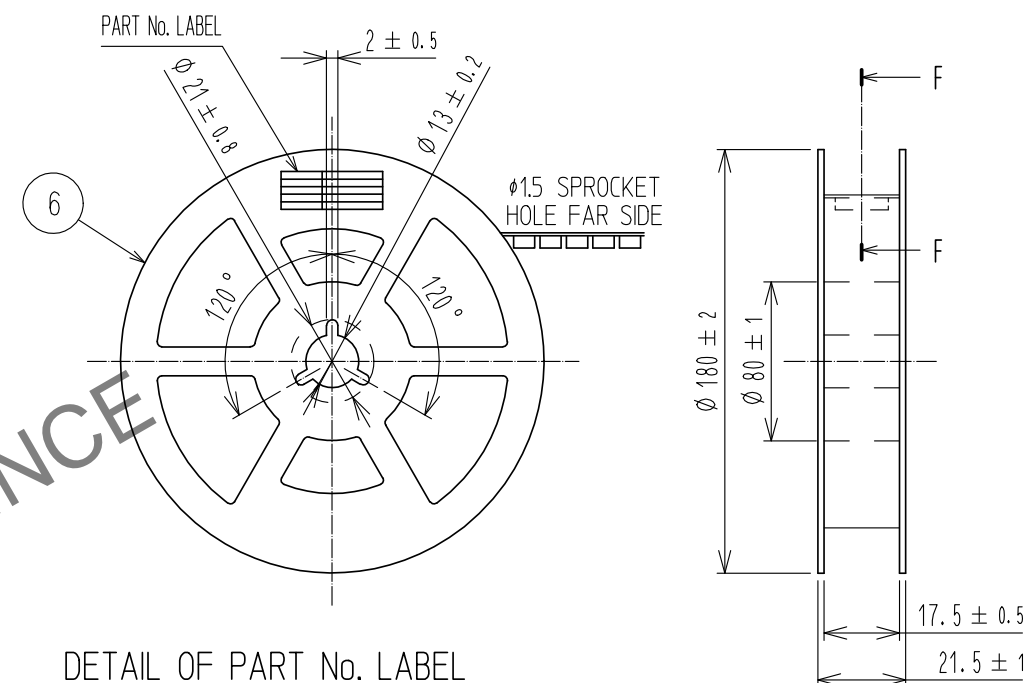

DETAIL OF PART No. LABEL

SUPPLIER	
QUANTITY	
PART No.	
CODE No.	
DATE OF MANUFACTURED	
製造年月日	** ** *
製品コード	CL673-1227-0-53
製品名	BM15FR0.8-20DS-0.35V(53)
数量	1,000
納入者	ヒロセ電機(株)

F-F (FREE)

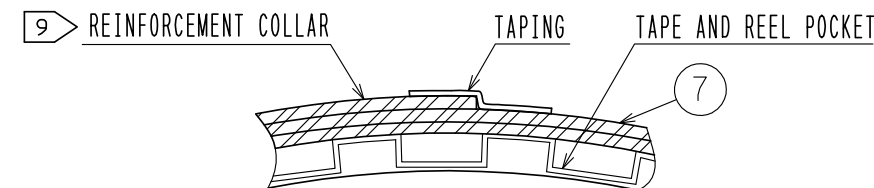

6. PER REEL 1000 CONNECTORS.

7. THE DIMENSIONS IN PARENTHESES ARE FOR REFERENCE.

8 REFER TO JIS C 0806 AND IEC 60286-3
 (PACKAGING OF COMPONENTS FOR AUTOMATIC HANDLING)

9 AFTER PACKAGING, ROLL 2 METERS OF THE REINFORCEMENT COLLAR TO OUTER CIRCUMFERENCE OF TAPE AND REEL POCKET, AND TAPE DOWN AT THE END THE COLLAR.

HRS

DRAWING NO.	EDC-355887-53-01
PART NO.	BM15FR0.8-20DS-0.35V(53)
CODE NO.	CL673-1227-0-53

3/3