



Tangshan Guoxin Jingyuan Electronics Co.,Ltd

Add: Xinxing Electronics Industrial Park, Yutian,Tangshan,Hebei,China

TEL: 86-315-6118243

E-mail: sales@jingyuan.com

FAX: 86-315-6113576

Web : www.jingyuan.com

APPROVAL SHEET

Customer : _____

Part Number : _____

JYEG P/N : JYOD3-(CMOS)

Holder : SMD 3225OSC

Frequency : 0.032768~93.750MHZ

Manufacturer : Guoxin Jingyuan Electronics

Date : 2025/12/29

Prepared	Checked	Approved
Huang Mingxing	Yang Tiesheng	Zhang Liqiang

(For Customer Use)

Acceptable	Non-Acceptable

1.This specification applies to SMD clock oscillator with a frequency of 0.032768~93.750MHz.

2. Electrical characteristics

ITEM/TYPE		OSC SMD3225	
Frequency Range		0.032768~93.750MHz(AT1)	
Frequency Stability		±25ppm/±30ppm/±50ppm/±100ppm,or specify	
Operating Temperature Range		-20~70℃/-40~85℃/-40~105℃/-40~125℃	
Output Load		1-5TTL or CMOS 30PF Max	
Input Current		1.8V~3.3V	5V
	32.768KHz	≤0.5mA	≤1mA
	≤35MHz	≤8mA	≤12mA
	35~50MHz	≤16mA	≤18mA
	>50MHz	≤25mA	≤30mA
Supply Voltage		5V±10%/3.3V±10%/2.5V±10%/1.8V±10%	
Start-up Time		1ms Max.(AT1),3ms Max.(AT3)	
Duty Cycle		40%-60% Normal,45%-55% Tight	
Rise/FallTime		5ns Max	
Out "0"Level		TTL	CMOS
		0.4VMax	10%VDD Max
Out "1"Level		TTL	CMOS
		2.4V Min	90% VDD Min
Tri-state		Pin1: 0.7VDD Min.(High) or open,Output: Enable Pin1: 0.3VDD Max.(Low), Out: Disable	
Jitter(12KHz-20MHz)		1ps Max	
Aging		±3ppm/year Max	
Storage Temperature Range		-55-125℃	

Note 1:frequency [tolerance@25℃](#) and frequency stability vs. operating temperature range and voltage variance.

3. Construction

3.1 Crystal enclosure seal:

- Seam seal
- resistance weld
- cold weld

3.2 crystal enclosure medium

- nitrogen
- vacuum
- dry air

4.Dimension:

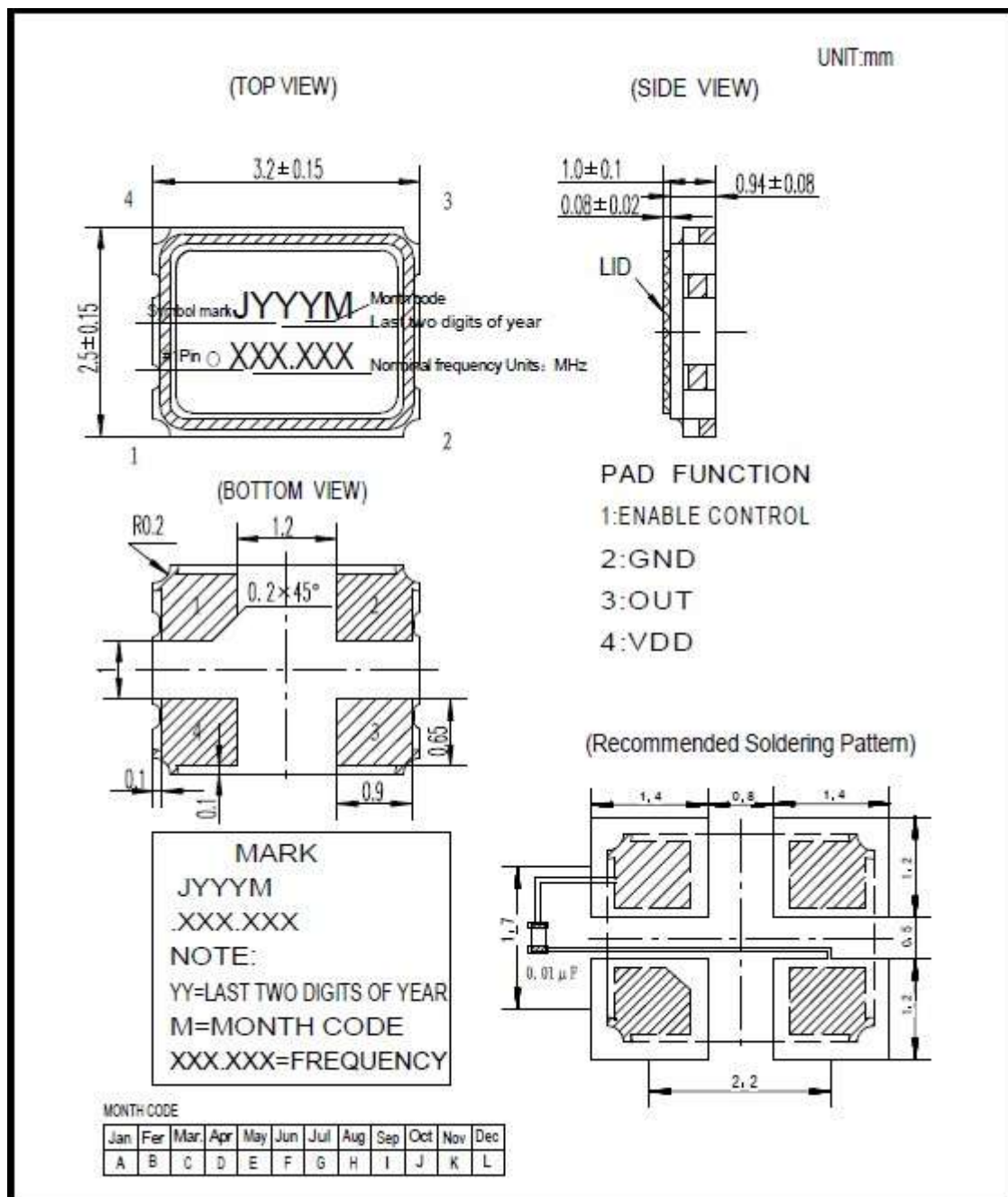

5. Marking

- Laser Marking
- Ink Marking

6. Inside Structure

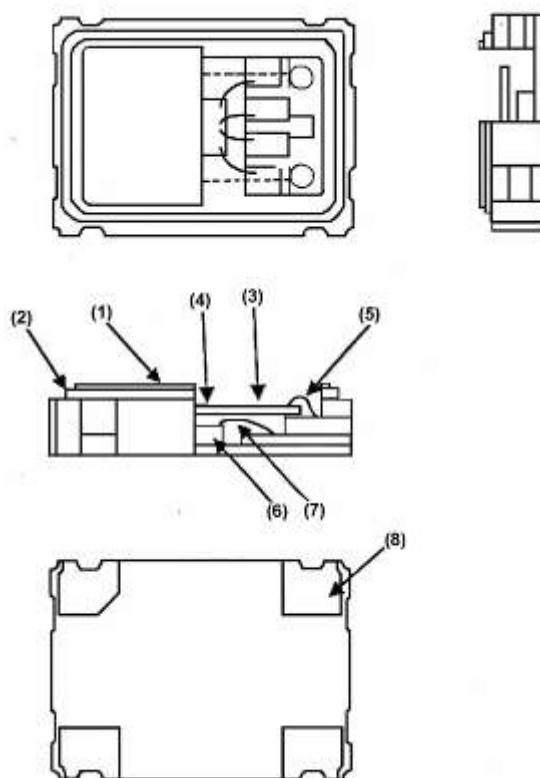

No.	Name	Material
(1)	Can	Fe-Co-Ni
(2)	Base	Ceramic
(3)	Blank	Quartz
(4)	Electrode	Ag
(5)	Epoxy	Silicon +Ag
(6)	IC	Silicon
(7)	Wire	Au
(8)	Soldering pads	Au plated

7.Taping Dimension and Packing Instruction

7.1

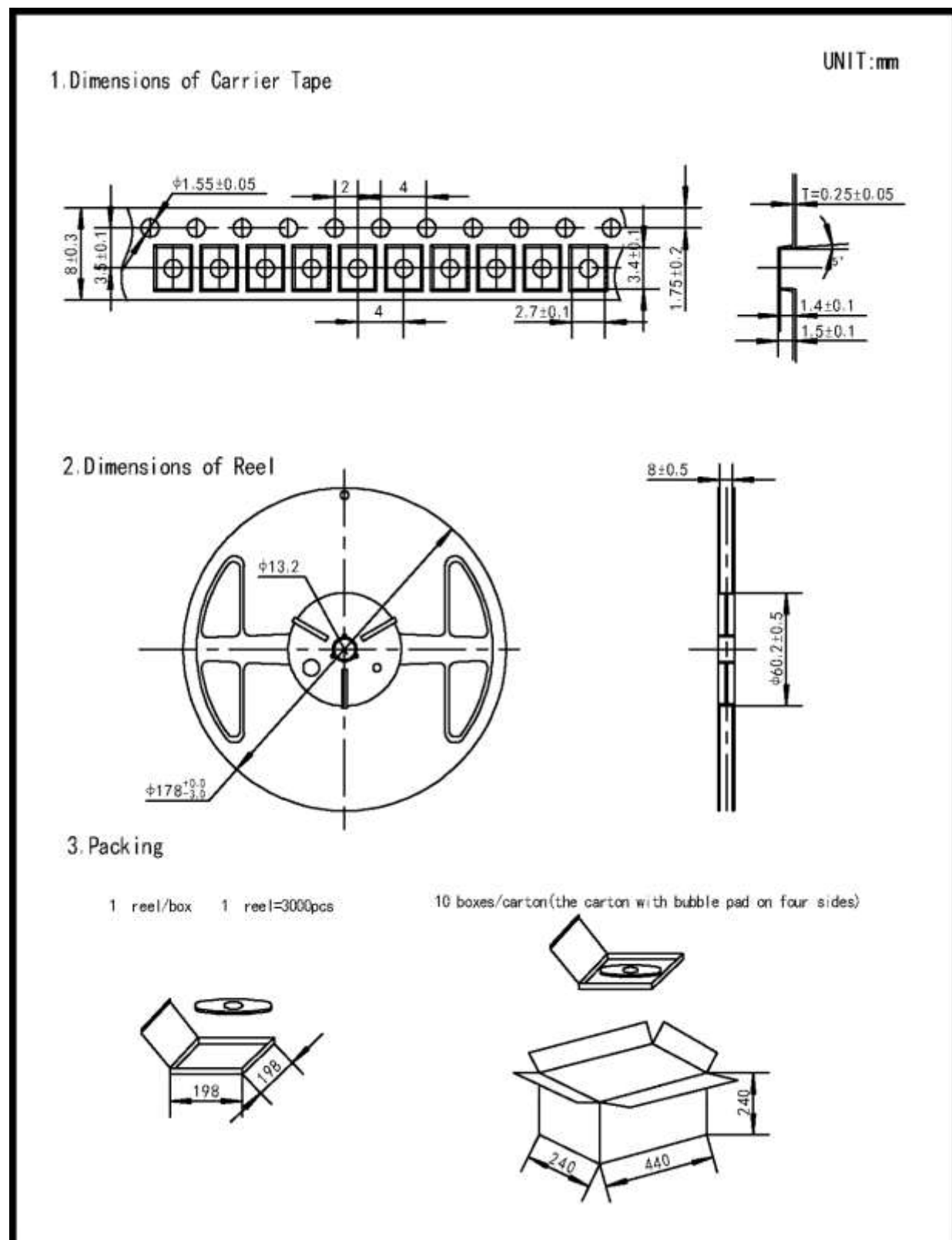

7.2

Release strength of cover tape

It has to be between 30g to 90g under following condition.

Pulling direction : 165 deg. to 180 deg.

Speed : 300mm/min.

Otherwise unless specified.

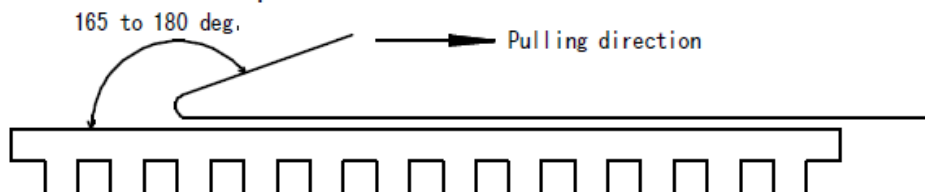

8. Test circuit

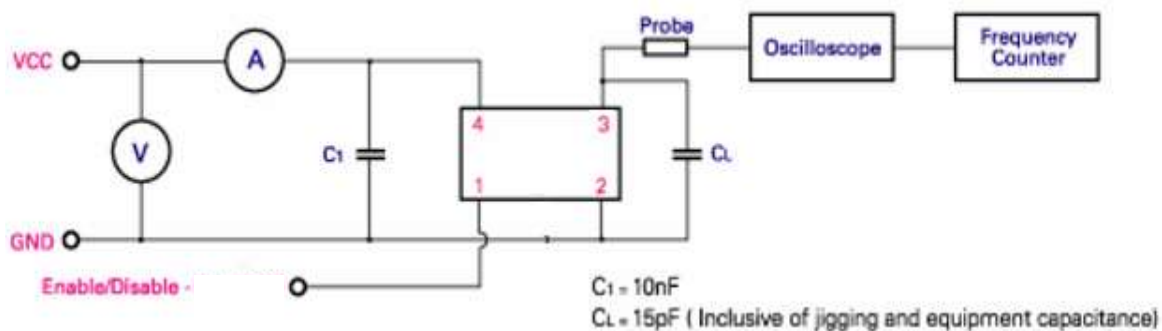

9. Electro-static Discharges

9.1 HBM/ESD and MM/ESD Classification

HBM/ESD Component Classification:

HBM/ESD	Voltage Range(V)
1	0~1999
2	2000~3999
3	4000~ABOVE

MM/ESD Component Classification:

MM/ESD	Voltage Range(V)
A	0~199
B	200~399
C	400~ABOVE

9.2 OSCILLATOR Production For ESD Classification:

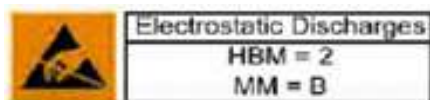

10. Reliability characteristic:				
NO	Item	Condition	Specifications	Reference
10.1	High Temperature Exposure (Storage) 高温存储	1000 hrs. at rated operating temperature r 1000 hrs at 85°C. n powered.Measurement at 24±2 hours after test conclusion. 元件就贮存在 85°C 下 1000 小时，在试验结 束后 24±2 小时测试。	$\Delta F/F0 \leq +/-10\text{ppm}$ $I \leq 5\text{mA or } 20\%$	MIL-STD-202 Method 108
10.2	Temperature Cycling 温度循环	-40° C to 125°C part the 1000 cycles will be at that perature rating.Measurement at 24 ± 2 hours after test conclusion. 30min maximum dwell time at each temperature extreme. 1 min. maximum transition time. 从 -40°C ~ +125°C 1000 次循环。在试验结束后 24±2 小时测试。每个温度的停留时间不超过 30 分钟。转换时间不超过 1 分钟。	$\Delta F/F0 \leq +/-10\text{ppm}$ $I \leq 5\text{mA or } 20\%$	JESD22 Method JA-104
10.3	Biased Humidity 稳态湿热	1000 hours 85°C/85%RH. Rated VDD applied with 1MΩ and inverter in parallel, 2X resonator CL capacitors between each resonator leg and GND.Measurement at 24±2 hours after test conclusion. 在温度 85°C，湿度 85% 的条件下放置 1000 个小时在试验结束后 24±2 小时测试。	$\Delta F/F0 \leq +/-10\text{ppm}$ $I \leq 5\text{mA or } 20\%$	MIL-STD-202 Method 103
10.4	Operational Life 高温寿命	125°C 1000 hrs. Measurement at 24±2 hours after test conclusion. 125°C 下 1000 个小时，用相同测试线路在时 间结束后 24±2 小时测试。	$\Delta F/F0 \leq +/-10\text{ppm}$ $I \leq 5\text{mA or } 20\%$	MIL-STD-202 Method 108
10.5	Vibration 振动	[10 Hz~2000 Hz 50 m/s ² (5 G) for 20 min 12 cycles each of 3 orientations.] PCB board. 10 Hz~2000 Hz 50 m/s ² (5 g)，持续 20 分 钟，3 个方向各 12 个循环，带 PCB 板。	$\Delta F/F0 \leq +/-10\text{ppm}$ $I \leq 5\text{mA or } 20\%$	MIL-STD-202 Method 204
10.6	Mechanical Shock 机械冲击	[1000 m/s ² (100 G) Half sine shock pulse] 1000 m/s ² (100 G) 半正弦冲击脉冲	$\Delta F/F0 \leq +/-10\text{ppm}$ $I \leq 5\text{mA or } 20\%$	MIL-STD-202 Method 213

10.7	Drop 跌落	Device are put on the weight of 200 g and dropped on concrete board. Height: 1.5 m 6axis*3times 配重 200 克, 高度:1.5 米, 掉在混凝土板上, 6 轴*3 次	$\Delta F/F0 \leq \pm 10\text{ppm}$ $I \leq 5\text{mA or } 20\%$	AEC-Q100
10.8	Resistance to Soldering Heat 耐焊接热	Condition B No pre-heat of samples. Note: SingleWave solder - Procedure 1 with solder within 1.5 mm of device body for Leaded. Procedure 1 except 245°C and immerse only to level to cover terminals for SMD. 未预热的样品 Condition B. 备注: 单波焊接 -Procedure 1 引脚产品焊料少于 1.5mm, 除了 245°C 外其他 Procedure 1, SMD 产品浸到覆盖 SMD 引脚。	$\Delta F/F0 \leq \pm 10\text{ppm}$ $I \leq 5\text{mA or } 20\%$	MIL-STD-202 Method 210
10.9	Solderability 可焊性	引脚产品: Method A@245°C, category 3. SMD 产品: Method D category3 @260°C ✓	Electrical Test not required. Magnification 50X. >95%tin 不测电参数 >95%浸润.	J-STD-002
10.10	Board Flex 线路板弯曲	60 sec minimum holding time. 最少保留 60 秒。	10 倍放大镜下检查没有明显伤痕。	AEC Q200-005
10.11	Terminal Strength 引线、引脚强度 (SMD)	Terminal Strength Surface Mount / Shear Stress Test 施加 1.8kg 力 60 sec 测试带引脚器件的引脚整体试验。 条件: A(2.27Kg) C(227g)	有明显断裂、伤痕。	AEC Q200-006

11.All products are RoHs compliant



12. Reflow Profile

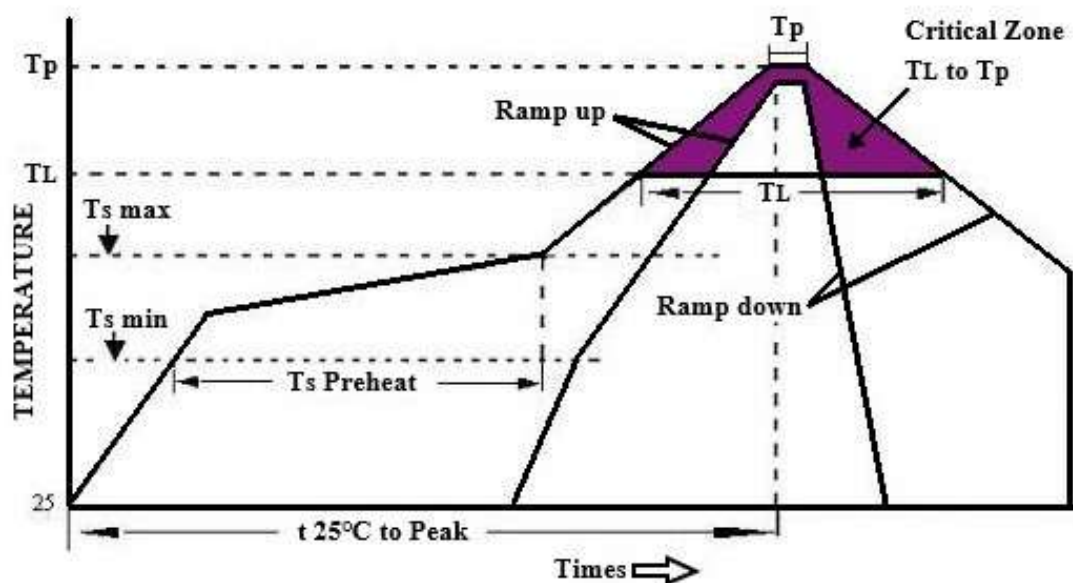

High Temperature Infrared /Convection

Note: Temperature shown are applied to body of device

Ts max to TL(Ramp-up Rate)	3°C/second max
Preheat	
Temperature Min(Ts Min)	150°C
Temperature Typical(Ts Typ)	175°C
Temperature Max.(Ts Max)	200°C
Time(ts)	60-180 seconds
Ram-up Rate(T _L to T _p)	3°C/second Max
Time Maintained Above:	
--Temperature(T _L)	217°C
--Time(T _L)	60-150seconds
Peak Temperature (T _p)	260°C Max for 10 seconds
Time within 5°C of actual peak(t _p)	20-40 seconds
Ramp-down Rate	6°C/seconds Max
Tune 25°C to Peak Temperature(t)	8 minutes Max
Moisture Sensitivity Level	Level 1

High Temperature Manual Soldering

Note: Temperature shown are applied to body of device

260°C Max for 10 seconds Max, 4 times Max

