

### GENERAL DESCRIPTION

The SGM42501 device is a brushed DC motor driver. This device integrates four N-MOSFETs, which can supply up to 3.6A peak current at 40V voltage.

The SGM42501 supports PH/EN interface. PWM signal can be implemented on the input interface to adjust motor speed. Customer can adjust PWM current limit or torque in real-time by VREF pin with a controller's DAC output or PWM signal after RC filter.

A number of protection features are provided in the device including over-current, short-circuit, under-voltage lockout and thermal shutdown. When the fault condition is removed, the device automatically resumes normal operation.

The SGM42501 is available in a Green SOIC-8 (Exposed Pad) package.

### FEATURES

- H-Bridge Motor Driver
- Operating Voltage Range: 7V to 40V
- Low On-Resistance: 0.41Ω (HS + LS) at +25°C
- 3.6A Peak Output Current
- Interface: PH/EN
- Adjustable PWM Current Limit in Real-Time
- Low Power Standby Mode
- Integrated Protection Features
  - ◆ Over-Current Protection (OCP)
  - ◆ Under-Voltage Lockout (UVLO)
  - ◆ Thermal Shutdown (TSD)
  - ◆ Auto-Retry
- Available in a Green SOIC-8 (Exposed Pad) Package

### APPLICATIONS

Printers  
 Vacuum Cleaners Robotics  
 Industrial Pumps and Valves

### TYPICAL APPLICATION

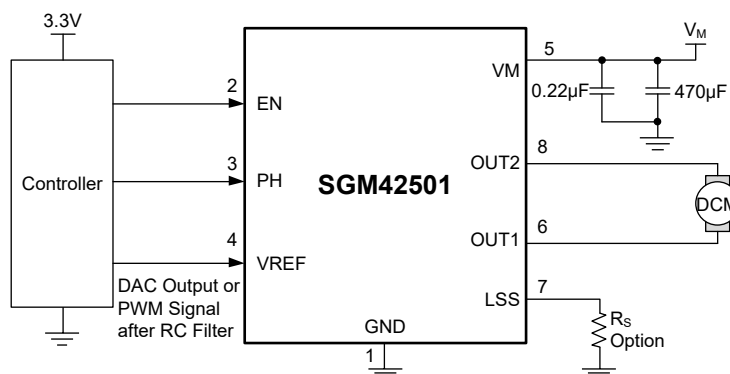

Figure 1. Typical Application Circuit

**PACKAGE/ORDERING INFORMATION**

MODEL	PACKAGE DESCRIPTION	SPECIFIED TEMPERATURE RANGE	ORDERING NUMBER	PACKAGE MARKING	PACKING OPTION
SGM42501	SOIC-8 (Exposed Pad)	-40°C to +125°C	SGM42501XPS8G/TR	SGM 42501XPS8 XXXXX	Tape and Reel, 4000

**MARKING INFORMATION**

NOTE: XXXXX = Date Code, Trace Code and Vendor Code.

**XXXXX**

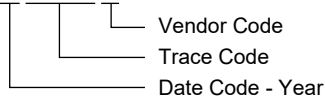

Green (RoHS & HSF): SG Micro Corp defines "Green" to mean Pb-Free (RoHS compatible) and free of halogen substances. If you have additional comments or questions, please contact your SGMICRO representative directly.

**ABSOLUTE MAXIMUM RATINGS**

Power Supply Voltage, $V_M$	45V
EN, PH	-0.3V to 6V
VREF	-0.3V to 5V
LSS	$\pm 0.5V$ (DC Condition)
	$\pm 2.5V$ (< 200ns)
Peak Output Current (Duty Cycle = 100%)	3.6A
Package Thermal Resistance	
SOIC-8 (Exposed Pad), $\theta_{JA}$	37°C/W
Junction Temperature	+150°C
Storage Temperature Range	-65°C to +150°C
Lead Temperature (Soldering, 10s)	+260°C
ESD Susceptibility	
HBM	2000V
CDM	1000V

**RECOMMENDED OPERATING CONDITIONS**

Power Supply Voltage, $V_M$	7V to 40V
Junction Temperature Range	-40°C to +150°C
Ambient Temperature Range	-40°C to +125°C

**OVERSTRESS CAUTION**

Stresses beyond those listed in Absolute Maximum Ratings may cause permanent damage to the device. Exposure to absolute maximum rating conditions for extended periods may affect reliability. Functional operation of the device at any conditions beyond those indicated in the Recommended Operating Conditions section is not implied.

**ESD SENSITIVITY CAUTION**

This integrated circuit can be damaged if ESD protections are not considered carefully. SGMICRO recommends that all integrated circuits be handled with appropriate precautions. Failure to observe proper handling and installation procedures can cause damage. ESD damage can range from subtle performance degradation to complete device failure. Precision integrated circuits may be more susceptible to damage because even small parametric changes could cause the device not to meet the published specifications.

**DISCLAIMER**

SG Micro Corp reserves the right to make any change in circuit design, or specifications without prior notice.

## PIN CONFIGURATION

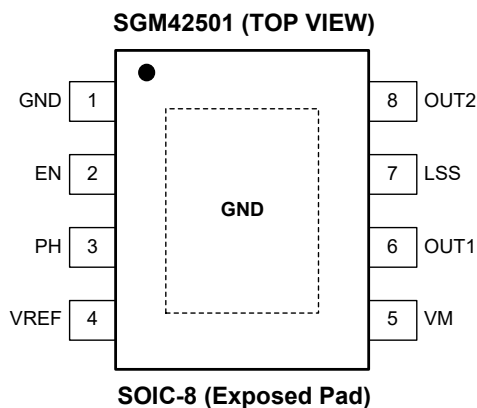

## PIN DESCRIPTION

PIN	NAME	TYPE	FUNCTION
1	GND	G	Ground.
2	EN	I	Enable Input. Logic low to place the H-bridge in brake mode or coast mode.
3	PH	I	Direction Input. Control the direction and speed of the H-bridge.
4	VREF	I	Analog Input. Analog input to set current limit.
5	VM	P	Supply Voltage.
6	OUT1	O	H-Bridge Output 1. Output of H-bridge driving stage.
7	LSS	O	Power Return. Sense resistor connection (option) or connect to power pad ground directly.
8	OUT2	O	H-Bridge Output 2. Output of H-bridge driving stage.
Exposed Pad	GND	-	Exposed Pad. Exposed pad for enhanced thermal dissipation.

NOTE: I: input, O: output, G: ground, P: power for the circuit.

## ELECTRICAL CHARACTERISTICS

(T<sub>J</sub> = +25°C, unless otherwise noted.)

PARAMETER	SYMBOL	CONDITIONS	MIN	TYP	MAX	UNITS
<b>Power Supply (VM)</b>						
Power Supply Voltage	V <sub>M</sub>		7		40	V
Power Supply Current	I <sub>VM</sub>	V <sub>M</sub> = 12V		2	3	mA
Standby Mode Supply Current	I <sub>VMQ</sub>	V <sub>M</sub> = 12V		3	5	μA
<b>Logic Level Inputs</b>						
Input Logic Low Voltage	V <sub>IL</sub>	T <sub>J</sub> = -40°C to +125°C			0.5	V
Input Logic High Voltage	V <sub>IH</sub>	T <sub>J</sub> = -40°C to +125°C	1.5			V
Input Logic Hysteresis	V <sub>HYS</sub>			350		mV
Input Logic Low Current	I <sub>IL</sub>	V <sub>EN</sub> or V <sub>PH</sub> = 0V	-1		1	μA
Input Logic High Current	I <sub>IH</sub>	V <sub>EN</sub> or V <sub>PH</sub> = 3.3V		25	100	μA
Pull-Down Resistance	R <sub>PD</sub>	To GND		130		kΩ
Propagation Delay Time	t <sub>PD</sub>	V <sub>EN</sub> or V <sub>PH</sub> to OUTx change		1.1		μs
<b>Motor Driver Outputs (OUT1 and OUT2)</b>						
High-side FET On-Resistance	R <sub>DSON</sub>	V <sub>M</sub> = 24V, I <sub>OUT</sub> = 0.5A		250	300	mΩ
Low-side FET On-Resistance		V <sub>M</sub> = 24V, I <sub>OUT</sub> = 0.5A		160	190	mΩ
Body Diode Forward Voltage <sup>(1)</sup>	V <sub>D</sub>	I <sub>OUT</sub> = 1A		0.8		V
<b>Timing</b>						
Turn-On Time <sup>(2)</sup>	t <sub>ON</sub>	V <sub>M</sub> > V <sub>UVLO</sub> with EN high		130		μs
Crossover Delay	t <sub>COD</sub>			400		ns
VREF Input Voltage Range	V <sub>REF</sub>		0		4	V
VREF Voltage Gain	A <sub>V</sub>	V <sub>REF</sub> /V <sub>LSS</sub> , V <sub>REF</sub> = 2.5V	9.2	10	11.3	V/V
Constant Off-Time	t <sub>OFF</sub>			12.5		μs
Standby Timer	t <sub>ST</sub>	EN = PH = 0V		1	1.5	ms
<b>Protection Circuits</b>						
VM Under-Voltage Lockout	V <sub>UVLO</sub>	V <sub>M</sub> falls until UVLO triggers		6	6.6	V
		V <sub>M</sub> rises until operation recovers		6.2	6.8	
VM Under-Voltage Hysteresis	V <sub>HYS</sub>	Rising to falling threshold	100	200		mV
Over-Current Protection Trip Level	I <sub>OCP</sub>			4		A
Over-Current Deglitch Time	t <sub>OCP</sub>			2		μs
Over-Current Retry Time	t <sub>RETRY</sub>			10		ms
Thermal Shutdown Temperature	T <sub>SD</sub>			165		°C
Thermal Shutdown Temperature Hysteresis	T <sub>HYS</sub>			30		°C

## NOTES:

1. It is recommended that the maximum current of the body diode should be less than 1.5A.
2. t<sub>ON</sub> applies when the device initially powers up, and when it exits standby mode.

PWM CONTROL TIMING DIAGRAM

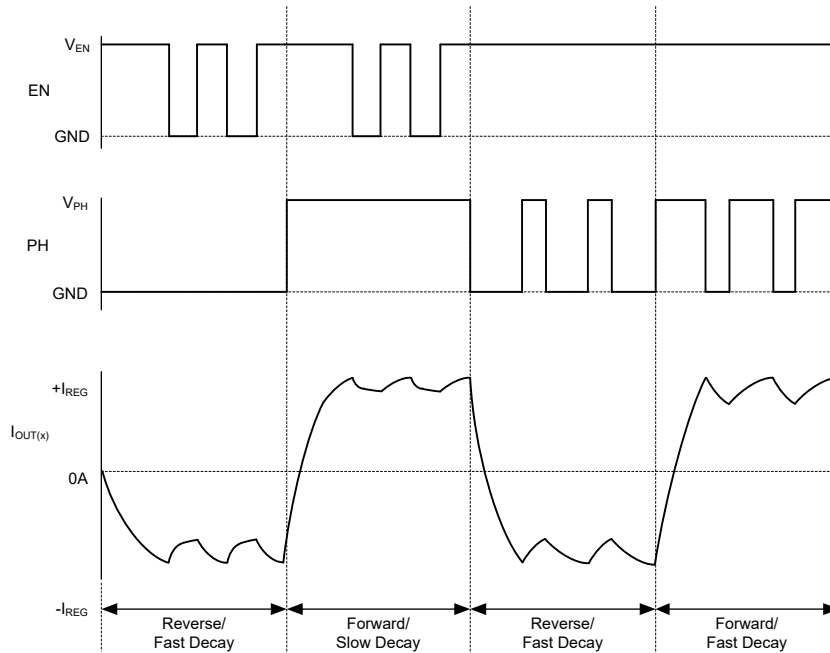

TRUTH TABLE

Table 1. SGM42501 PH/EN Control Truth Table

EN	PH	OUT1	OUT2	Function
1	0	L	H	Reverse
1	1	H	L	Forward
0	1	L	L	Brake (Slow Decay)
0	0	Z	Z	Coast, enter in the low power standby mode after 1ms. It will be a fast decay that discharges through the body diode.

NOTE: Z = high-impedance.

Table 2. SGM42501 PWM Decay Logic

EN	PH	Decay Logic
1	PWM	Fast Decay
PWM	0	Fast Decay
PWM	1	Slow Decay

The inputs can also be used for PWM control, for example, the speed of a DC motor.

The PWM signal can be applied to EN or PH pin.

If PWM signal is applied to EN pin, the PH pin is set to high or low to control the motor direction. When PH is high, the motor is running forward, and the decay mode is the slow decay. When PH is low, the motor is running reverse, and the decay mode is the fast decay.

If PWM signal is applied to PH pin, the decay mode is fast decay and the EN pin needs to be set high to enable the output. When PWM duty cycle is from 50% to 100%, the motor is running forward. When PWM duty cycle is from 0% to 50%, the motor is running reverse.

FUNCTIONAL BLOCK DIAGRAM

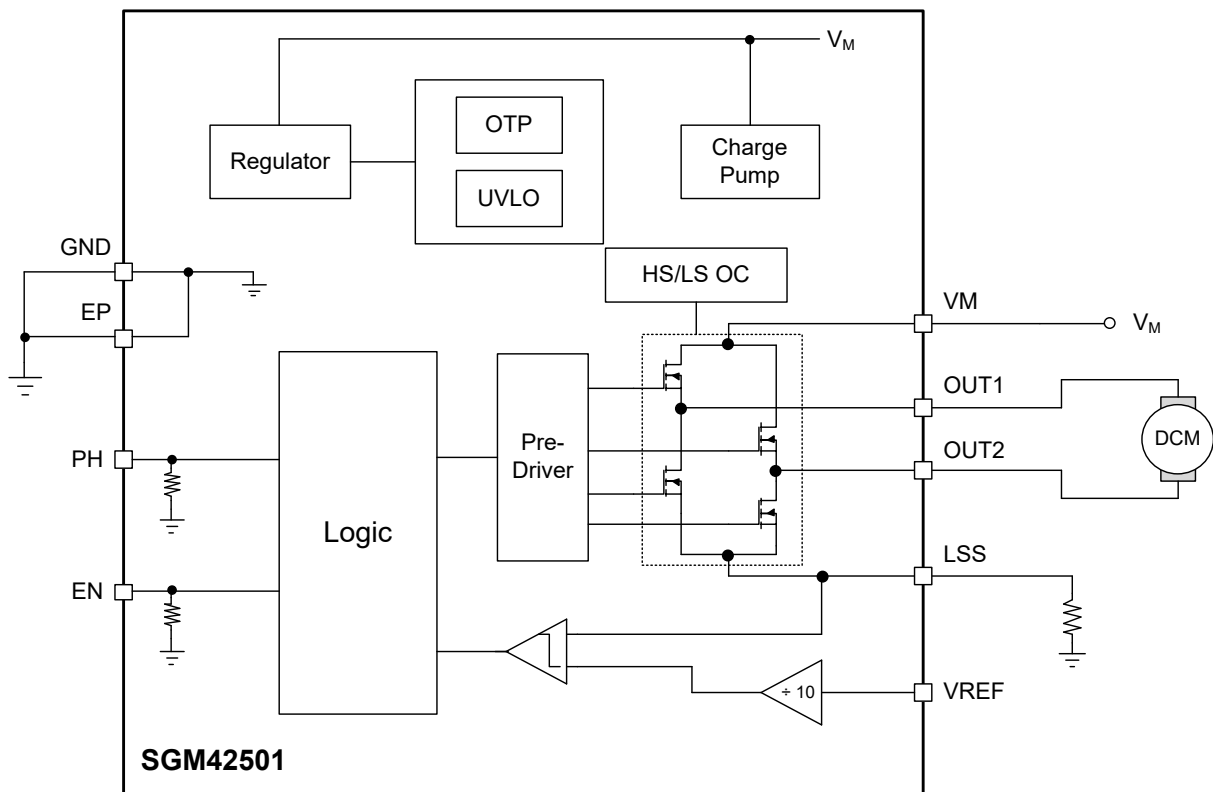
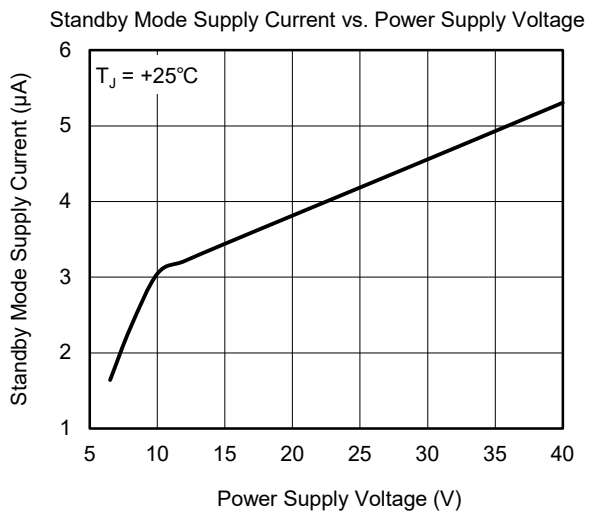
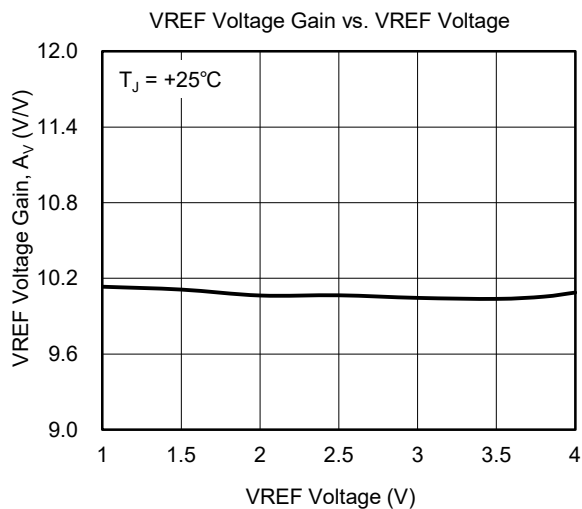
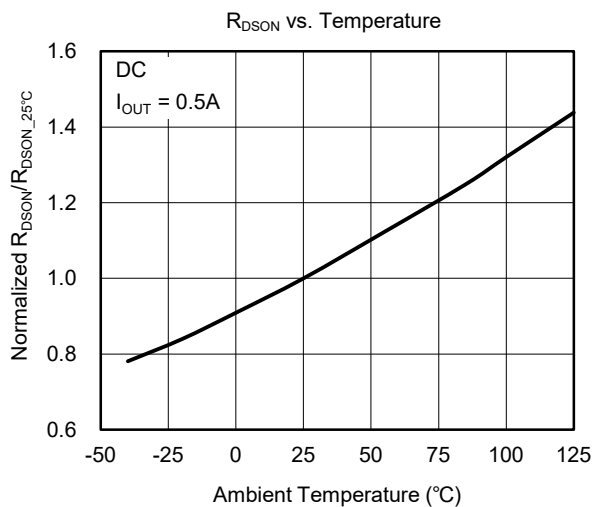

Figure 2. SGM42501 Functional Block Diagram

TYPICAL PERFORMANCE CHARACTERISTICS



## DETAILED DESCRIPTION

### Device Operation

The SGM42501 is typically used to drive a DC motor. An internal charge pump generates the necessary gate-drive voltage. The SGM42501 operates from 7V to 40V motor power supply, which can supply a 3.6A peak current. Full protection features include over-current protection, under-voltage lockout and over-temperature protection.

### Standby Mode

For SGM42501, the device will go to standby mode if EN/PH pins are low for longer than 1ms. If entering the standby mode, the output MOSFET, charge pump, and regulator are turned off for saving power.

### Internal PWM Current Control

The current in the output is limited using fixed off-time control circuitry. If the motor current goes over the current limit setting, the two low-side MOSFETs are both turned on for  $t_{OFF}$  time, slow decay mode is used to adjust the current.

### $V_{REF}$

The current limit is decided by  $V_{REF}$  and  $R_S$  together, please refer to Equation 1:

$$I_{TRIPMAX} = \frac{V_{REF}}{10 \times R_S} \quad (1)$$

### Over-Current Protection (OCP)

Each MOSFET is protected by its own preset over-current limit. In case of an over-current (any direction), the whole bridge will be disabled (shutdown), and the device will retry after  $t_{RETRY}$ . An over-current will occur due to a short between a switching node and ground, VM supply line, or the other node of the bridge (a winding short).

### Thermal Shutdown (TSD)

The driver is shutdown if a junction over-temperature occurs in the device. Once the temperature goes back to the safe level, the device resumes its operation.

### Under-Voltage Lockout (UVLO)

If the voltage on VM pin falls below its under-voltage lockout threshold, the device will be disabled. The device resumes operation when the power supply goes back above UVLO thresholds.



APPLICATION INFORMATION

Sense Pin (LSS)

If PWM current control is used, it is recommended to place a low-value resistor between the LSS and GND pins for current sensing. In order to detect the output current, the ground trace IR drop should be minimized. Surface mounted and low inductance sense resistor is recommended. It is necessary to consider the package, since I^2 x R heat is generated in the sense resistor. And during PCB layout, place the resistor near to the motor driver as close as possible.

Ensure that the maximum voltage of LSS (±500mV) is not exceeded at the maximum load, and select the appropriate resistance value. This rating may be exceeded for a short time during an over-current event.

Ground and Layout Guidelines

The power supply VM is suggested to be decoupled with a bulk capacitor in parallel with a lower value ceramic capacitor placed as close as practicable to the device.

The exposed pad on the bottom of the device provides a path for heat dissipation. The pad should be soldered directly to an exposed surface on the PCB board to achieve better thermal performance. Thermal vias are also helpful to dissipate the heat.

It is good to have a low impedance single-point ground, known as a star ground, which is located close to the SGM42501. The copper ground plane located under the device thermal pad is typically used as the star ground.

REVISION HISTORY

NOTE: Page numbers for previous revisions may differ from page numbers in the current version.

Table with 2 columns: Revision Description and Page. Includes entries for JANUARY 2023 - REV.A to REV.A.1 and Changes from Original (OCTOBER 2022) to REV.A.

PACKAGE OUTLINE DIMENSIONS

SOIC-8 (Exposed Pad)

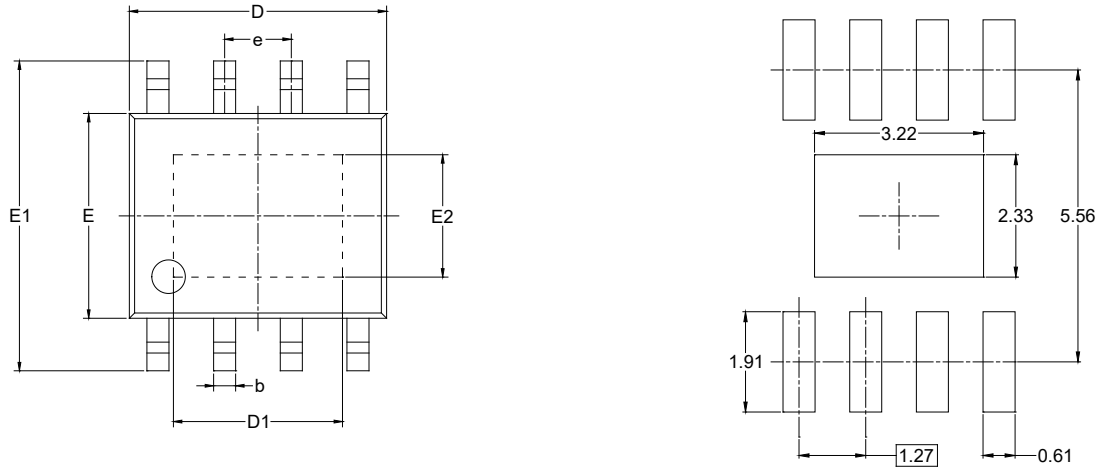

RECOMMENDED LAND PATTERN (Unit: mm)

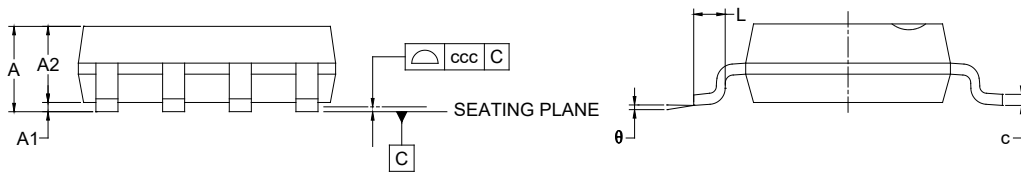

Symbol	Dimensions In Millimeters		
	MIN	MOD	MAX
A			1.700
A1	0.000	-	0.150
A2	1.250	-	1.650
b	0.330	-	0.510
c	0.170	-	0.250
D	4.700	-	5.100
D1	3.020	-	3.420
E	3.800	-	4.000
E1	5.800	-	6.200
E2	2.130	-	2.530
e	1.27 BSC		
L	0.400	-	1.270
$\theta$	0°	-	8°
ccc	0.100		

NOTES:

1. This drawing is subject to change without notice.
2. The dimensions do not include mold flashes, protrusions or gate burrs.
3. Reference JEDEC MS-012.

# PACKAGE INFORMATION

## TAPE AND REEL INFORMATION

### REEL DIMENSIONS



### TAPE DIMENSIONS



NOTE: The picture is only for reference. Please make the object as the standard.

### KEY PARAMETER LIST OF TAPE AND REEL

Package Type	Reel Diameter	Reel Width W1 (mm)	A0 (mm)	B0 (mm)	K0 (mm)	P0 (mm)	P1 (mm)	P2 (mm)	W (mm)	Pin1 Quadrant
SOIC-8 (Exposed Pad)	13"	12.4	6.40	5.40	2.10	4.0	8.0	2.0	12.0	Q1

000001

# PACKAGE INFORMATION

## CARTON BOX DIMENSIONS



NOTE: The picture is only for reference. Please make the object as the standard.

## KEY PARAMETER LIST OF CARTON BOX

Reel Type	Length (mm)	Width (mm)	Height (mm)	Pizza/Carton
13"	386	280	370	5

DD0002