

A-INL-M12-N-S - Counter nut

1411240

<https://www.phoenixcontact.com/us/products/1411240>

Please be informed that the data shown in this PDF document is generated from our online catalog. Please find the complete data in the user documentation. Our general terms of use for downloads are valid.

Counter nut, for threads M12 x 1.5, color: silver



Commercial data

Item number	1411240
Packing unit	100 pc
Minimum order quantity	100 pc
Sales key	BF68
Product key	BF7DZX
Catalog page	Page 688 (C-2-2019)
GTIN	4046356923712
Weight per piece (including packing)	1.963 g
Weight per piece (excluding packing)	1.919 g
Customs tariff number	74198090
Country of origin	IN

A-INL-M12-N-S - Counter nut

1411240

<https://www.phoenixcontact.com/us/products/1411240>

Technical data

Product properties

Product type	Flat nut
Thread type	M12

Data management status

Article revision	00
------------------	----

Dimensions

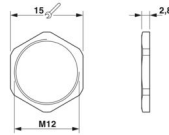
Dimensional drawing	
Length	2.8 mm
Diameter	12 mm
Connecting thread diameter	12 mm
Wrench size, counter nut	15 mm
Hexagon angular dimension	16.5 mm
Thread type connection side	M12 x 1.5
Thread pitch	1.5 mm

Material specifications

Material	Brass, nickel-plated
----------	----------------------

Cable/line

Halogen-free	yes
--------------	-----

Environmental and real-life conditions

Ambient conditions

Ambient temperature (operation)	-70 °C ... 220 °C
---------------------------------	-------------------

A-INL-M12-N-S - Counter nut

1411240

<https://www.phoenixcontact.com/us/products/1411240>



Drawings

Dimensional drawing

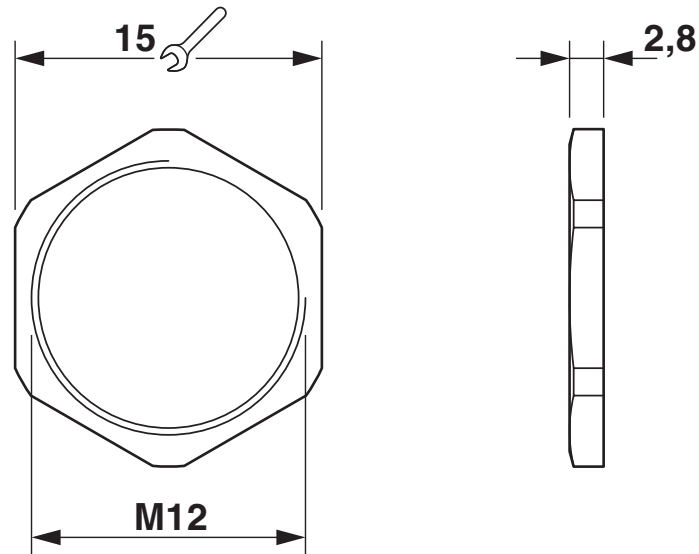

A-INL-M12-N-S - Counter nut



1411240

<https://www.phoenixcontact.com/us/products/1411240>

Classifications

ECLASS

ECLASS-11.0	27144424
ECLASS-13.0	27140807

ETIM

ETIM 9.0	EC000879
----------	----------

UNSPSC

UNSPSC 21.0	31161700
-------------	----------

A-INL-M12-N-S - Counter nut



1411240

<https://www.phoenixcontact.com/us/products/1411240>

Environmental product compliance

EU RoHS

Fulfills EU RoHS substance requirements	Yes
Exemption	6(c)

China RoHS

Environment friendly use period (EFUP)	EFUP-50
	An article-related China RoHS declaration table can be found in the download area for the respective article under "Manufacturer declaration". For all articles with EFUP-E, no China RoHS declaration table issued and required.

EU REACH SVHC

REACH candidate substance (CAS No.)	Lead(CAS: 7439-92-1)
SCIP	c5782d7b-cf9a-47ef-b855-1f1f49e5ec29

Phoenix Contact 2024 © - all rights reserved
<https://www.phoenixcontact.com>

Phoenix Contact USA
586 Fulling Mill Road
Middletown, PA 17057, United States
(+717) 944-1300
info@phoenixcon.com