

ADF18S28B

AC-DC Converter Technical Manual V1.1

Full-Brick
AC-DC Converter

90 - 290 V AC
Input

28 V DC Output

18 A Current

Negative logic

Description

The ADF18S28B is a new generation isolated AC-DC converter that uses an industry standard full-brick structure, featuring high efficiency and power density with low output ripple and noise. It operates from an input voltage range of 90 V AC to 290 V AC, and provides the rated output voltage of 28 V DC as well as the maximum output current of 18 A.

Operational Features

- Rated input voltage: 110/220 V AC
- Output current: 0 - 18 A
- Efficiency: 92% (28 V DC, 18 A)

Mechanical Features

- Industry standard full-brick (L x W x H): 116.8 mm x 61.0 mm x 12.7 mm (4.60 in. x 2.40 in. x 0.50 in.)
- Weight: 190 g

Control Features

- Remote on/off
- Remote sense
- Output voltage Trim
- PMBus communication

Protection Features

- Input undervoltage protection
- Input overvoltage protection
- Output overcurrent protection (Self-recovery)
- Output overvoltage protection (Latch off)
- Output short circuit protection (Self-recovery)
- Overtemperature protection (Self-recovery)



ADF18S28B

Safety Features

- TUV, UL, CE certification
- Meet UL60950-1, EN 60950-1 and IEC 60950-1
- Meet RoHS6 requirement

Applications

- Servers/Storages
- Routers/Switches
- Telecommunications equipment
- Enterprise networks

ADF18S28B

AC-DC Converter Technical Manual V1.1

Designation Explanation

ADF 18 S 28 B
1 2 3 4 5

- 1 — AC input, digital control, full-brick
- 2 — Output current: 18 A
- 3 — Single output
- 4 — Output voltage: 28 V
- 5 — With a baseplate

Mechanical Diagram

Pin Description

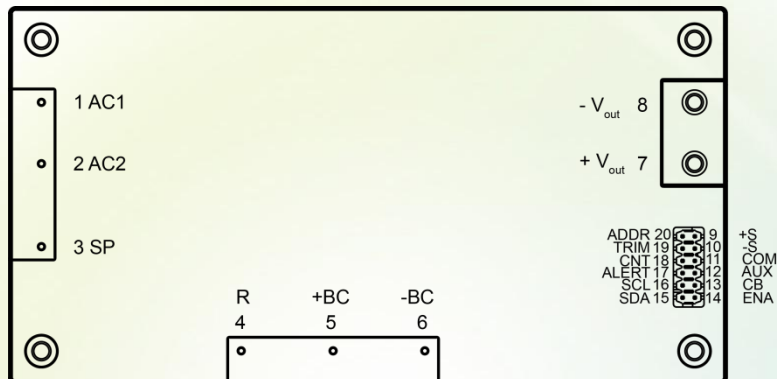

Pin No.	Name	Function	Pin No.	Name	Function
1	AC1	AC input	11	COM	Common ground
2	AC2		12	AUX	Auxiliary power supply
3	SP	Surge protection	13	CB	Current balance for parallel operation
4	R	External resistor for inrush current protection	14	ENA	Enable signal or input power failure signal
5	+BC	Boost output voltage (+)	15	SDA	PMBus serial data line
6	-BC	Boost output voltage (-)	16	SCL	PMBus serial clock line
7	+V _{out}	Output voltage (+)	17	ALERT	PMBus alert
8	-V _{out}	Output voltage (-)	18	CNT	On/Off control (output side)
9	+S	Remote sense (+)	19	TRIM	Adjustment of output voltage
10	-S	Remote sense (-)	20	ADDR	Module address

ADF18S28B

AC-DC Converter Technical Manual V1.1

Mechanical Diagram

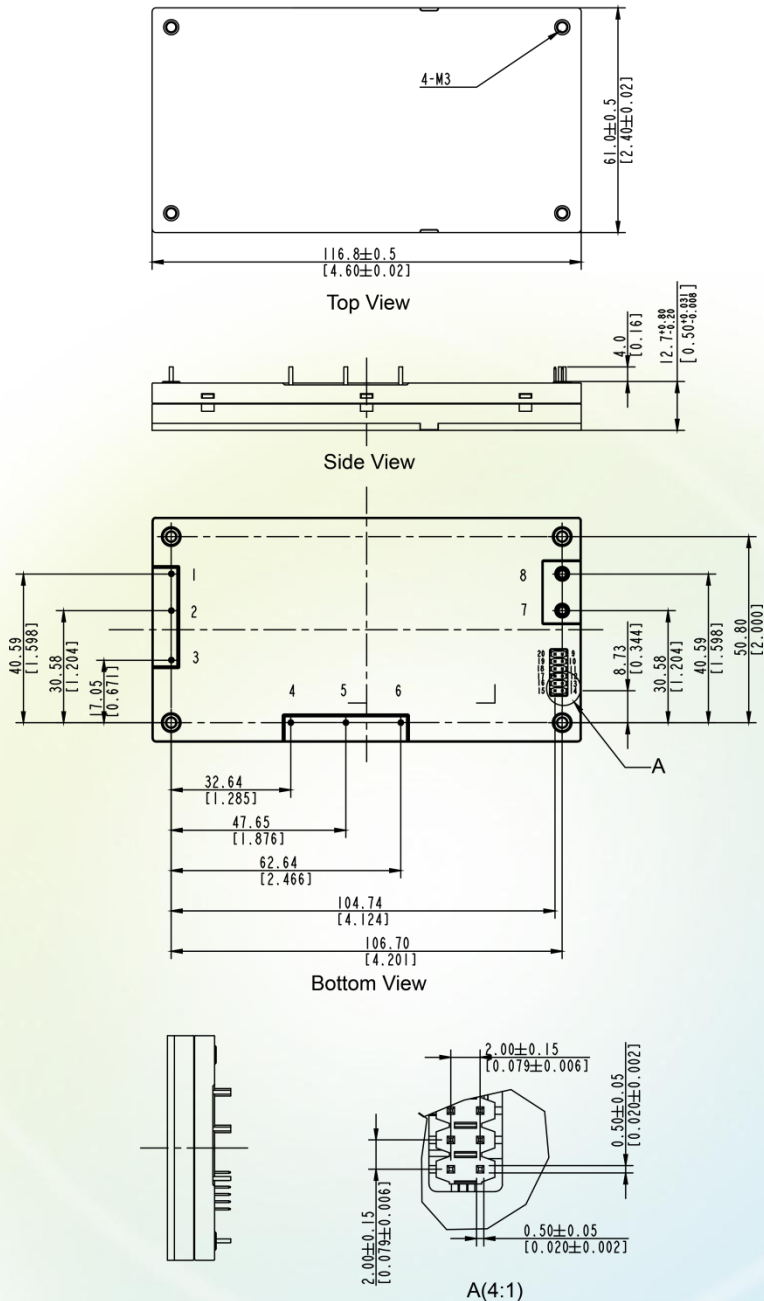

NOTE

1. All dimensions in mm [in.]. Tolerances: $x.x \pm 0.5$ mm [$x.xx \pm 0.02$ in.], $x.xx \pm 0.25$ mm [$x.xx \pm 0.010$ in.] except special declaration.
2. Pin 1 - 6 are 1.00 ± 0.05 mm [0.039 ± 0.002 in.] diameter, pin 7 and pin 8 are 2.0 ± 0.05 mm [0.079 ± 0.002 in.] diameter.
3. Unit: MKS

ADF18S28B

AC-DC Converter Technical Manual V1.1

Electrical Specifications

Parameter	Min.	Typ.	Max.	Unit	Notes & Conditions
Environment characteristics					
Operating ambient temperature	-40	-	85	°C	-
Storage and transportation temperature	-55	-	125	°C	-
Operating and storage humidity	10	-	95	%RH	Non-condensing
Altitude range	0	-	5000	m	Certification: 4000 m
Baseplate temperature	-40	-	90	°C	-
Absolute maximum ratings					
Input voltage Continuous	-	-	315	V AC	-
Baseplate temperature	-	-	90	°C	Conduction cooled
Voltage to SCL/SDA/ADDR/CB	-	-	3.6	V	-
Module number of parallel operation	-	-	2	pcs	-
Input characteristics					
Operating input voltage	90	-	290	V AC	-
Rated input voltage	100	110/220	240	V AC	-
Maximum input current	-	-	8	A	$V_{in} = 90$ V AC, 100% load
Input inrush current	-	-	20	A	$V_{in} = 110$ V AC
	-	-	40	A	$V_{in} = 220$ V AC
Input frequency	47	50/60	63	Hz	-
Power factor	0.95	-	-	-	$T_A = 25^\circ\text{C}$, $V_{in} = 110/220$ V AC, 100% load
Total harmonic distortion (THD)	-	-	10	%	$T_A = 25^\circ\text{C}$, $V_{in} = 110/220$ V AC, $P_{out} = 500$ W
No-load loss	-	-	10	W	$T_A = 25^\circ\text{C}$, $V_{in} = 110$ V AC
	-	-	12	W	$T_A = 25^\circ\text{C}$, $V_{in} = 220$ V AC
Standby power loss	-	-	5	W	$T_A = 25^\circ\text{C}$, $V_{in} = 110/220$ V AC
Output characteristics					
Output voltage trim range	20	-	32	V DC	By I2C or analog, the analog mode takes priority over the I2C mode
Output voltage set point	27.72	28.00	28.28	V DC	$T_A = 25^\circ\text{C}$, $V_{in} = 110/220$ V AC, 50% load
Output power	-	-	500	W	See Figure 3

ADF18S28B

AC-DC Converter Technical Manual V1.1

Electrical Specifications

Parameter	Min.	Typ.	Max.	Unit	Notes & Conditions
Output characteristics					
Line regulation	-0.3	-	0.3	%	$V_{out} = 28\text{ V DC}$, $P_{out} = 500\text{ W}$
Load regulation	-0.8	-	0.8	%	-
Regulated voltage precision	-3	-	3	%	The whole range of V_{in} , I_{out} and T_A
Temperature coefficient	-0.02	-	0.02	%/°C	The whole range of V_{in} , I_{out} and T_A
External load capacitor	470×3	-	470×11	μF	Output capacitor: low ESR aluminum capacitor (Recommend product model: EKY-630ELL471MK25S NCC)
	390	-	390×2	μF	Boost voltage bulk capacitor: long life aluminum capacitor (Recommend product model: ELXS451VSN391MR50S NCC)
Output ripple and noise (peak to peak)	-	-	320	mV	-5°C ≤ T_A ≤ 85°C Oscilloscope bandwidth: 20 MHz
	-	-	640	mV	-25°C ≤ T_A < -5°C Oscilloscope bandwidth: 20 MHz
	-	-	640	mV	-40°C ≤ T_A < -25°C Oscilloscope bandwidth: 20 MHz
Hold up time	10	-	-	ms	Output capacitor: 470 μF × 3 Bulk capacitor: 390 μF $T_A = 25^\circ\text{C}$, 100% load, from input power outage drop to 90% V_{out}
Output voltage delay time	-	-	8	s	From V_{in} connection to 10% V_{out}
Output voltage rise time	-	-	100	ms	From 10% V_{out} to 90% V_{out} , $T_A \geq -25^\circ\text{C}$
	-	-	400	ms	From 10% V_{out} to 90% V_{out} , -40°C ≤ T_A < -25°C When the temperature is below -25°C, there are no requirement on the output voltage rise waveform
Output voltage overshoot	-	-	5	%	The whole range of V_{in} , I_{out} and T_A
Current sharing accuracy	-10	-	10	%	Each output power > 200 W. The voltage difference between parallel modules should be less than 5%
Protection characteristics					
Input undervoltage protection					
Startup threshold	-	-	90	V AC	-
Shutdown threshold	74	-	85	V AC	-
Hysteresis	5	-	-	V AC	-

ADF18S28B

AC-DC Converter Technical Manual V1.1

Electrical Specifications

Parameter	Min.	Typ.	Max.	Unit	Notes & Conditions
Protection characteristics					
Input overvoltage protection					
Startup threshold	290	-	-	V AC	-
Shutdown threshold	295	-	310	V AC	
Hysteresis	5	-	-	V AC	
Output overvoltage protection	-	-	37	V	Latch off
Output overcurrent protection	105	-	150	%	Self-recovery
Output short circuit protection	-	-	-	-	Self-recovery; The converter is not damaged even with long-term short circuits
Overtemperature protection					Self-recovery; The values are obtained by measuring the temperature of the middle of the baseplate
Baseplate	95	-	-	°C	
Hysteresis	5	-	-	°C	
Dynamic characteristics					
Overshoot amplitude	-	-	5	%	T _A = 25°C, V _{in} = 110/220 V AC Current change rate: 0.1 A/μs, Load: 25% - 50% - 25%; 50% - 75% - 50%
Recovery time	-	-	250	μs	
Efficiency					
100% load	88	89	-	%	T _A = 25°C, V _{in} = 110 V AC; I _{out} = 18 A
	91	92	-	%	T _A = 25°C, V _{in} = 220 V AC; I _{out} = 18 A
50% load	88	89	-	%	T _A = 25°C, V _{in} = 110 V AC; I _{out} = 9 A
	90	92	-	%	T _A = 25°C, V _{in} = 220 V AC; I _{out} = 9 A
Other characteristics					
Remote on/off voltage					Negative logic
Low level	0	-	0.8	V	
High level	2.4	-	3.5	V	
AUX	10	-	14	V	Auxiliary power output, the output current is less than 20 mA
ENA	-	-	-	-	See Enable (ENA)
+S	-	-	5	%V _{out}	See Remote Sense
-S	-	-	0.5	V	
CB	0	-	3.3	V	Sharing bus, CB to -S
TRIM	0	-	2.5	V	TRIM to -S

ADF18S28B

AC-DC Converter Technical Manual V1.1

Electrical Specifications

Parameter	Min.	Typ.	Max.	Unit	Notes & Conditions
Other characteristics					
Input voltage reported precision	-10	-	10	V	$T_A = 25^\circ\text{C}$, $V_{in} = 90 - 290 \text{ V AC}$
Insulation characteristics					
Input to output insulation voltage	-	-	4242	V DC	Reinforced insulation; The leakage current should be less than 10 mA, test voltage ramp up less than 500 V/S
Input to baseplate insulation voltage	-	-	3535	V DC	
Output to baseplate insulation voltage	-	-	707	V DC	
Input to output insulation resistance	10	-	-	M Ω	Normal atmospheric pressure; 90% humidity; 500 V DC
Input to baseplate insulation resistance	10	-	-	M Ω	
Output to baseplate insulation resistance	10	-	-	M Ω	
Reliability characteristics					
Mean time between failures (MTBF)	-	1.2	-	Million hours	$T_{\text{Baseplate}} = 25^\circ\text{C}$, Telcordia SR332 Method 1 Case3; Normal Input/Rated Output, 80% load

Specifications are subject to change without notice.

ADF18S28B

AC-DC Converter Technical Manual V1.1

Characteristic Curves

Conditions: $T_A = 25^\circ\text{C}$.

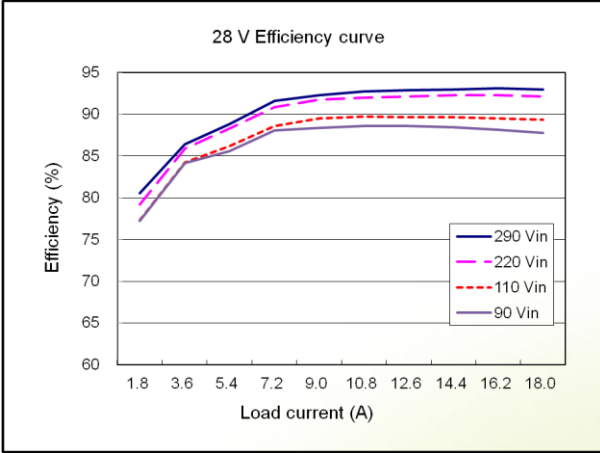

Figure 1: Efficiency

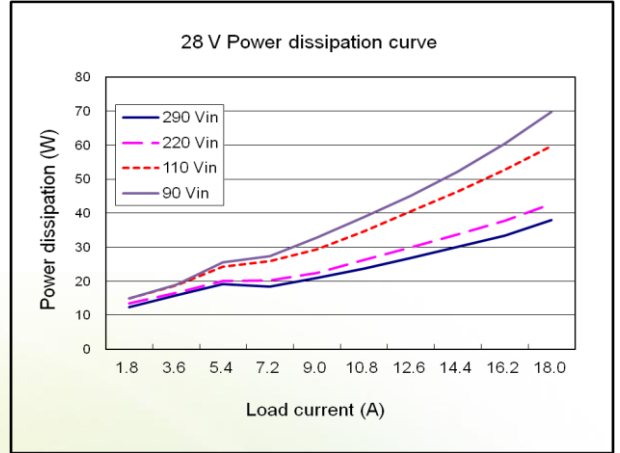

Figure 2: Power dissipation

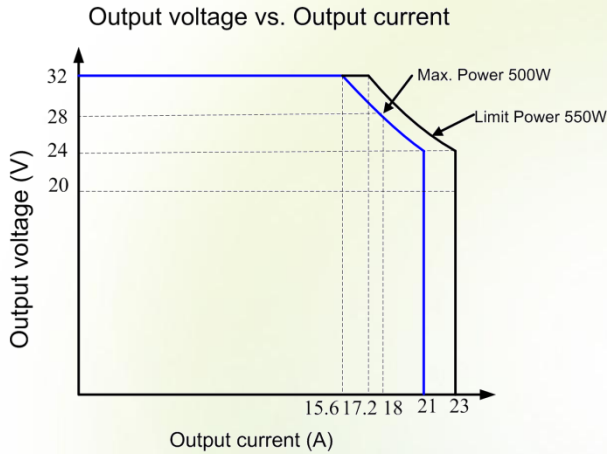

Figure 3: Output voltage vs. Output current

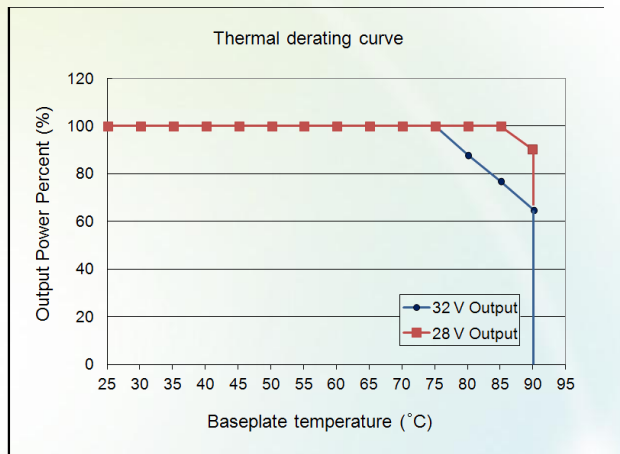

Figure 4: Thermal derating curve ($V_{in} = 110/220\text{ V}$, ambient temperature $T_A = 85^\circ\text{C}$)

ADF18S28B

AC-DC Converter Technical Manual V1.1

Typical Waveforms

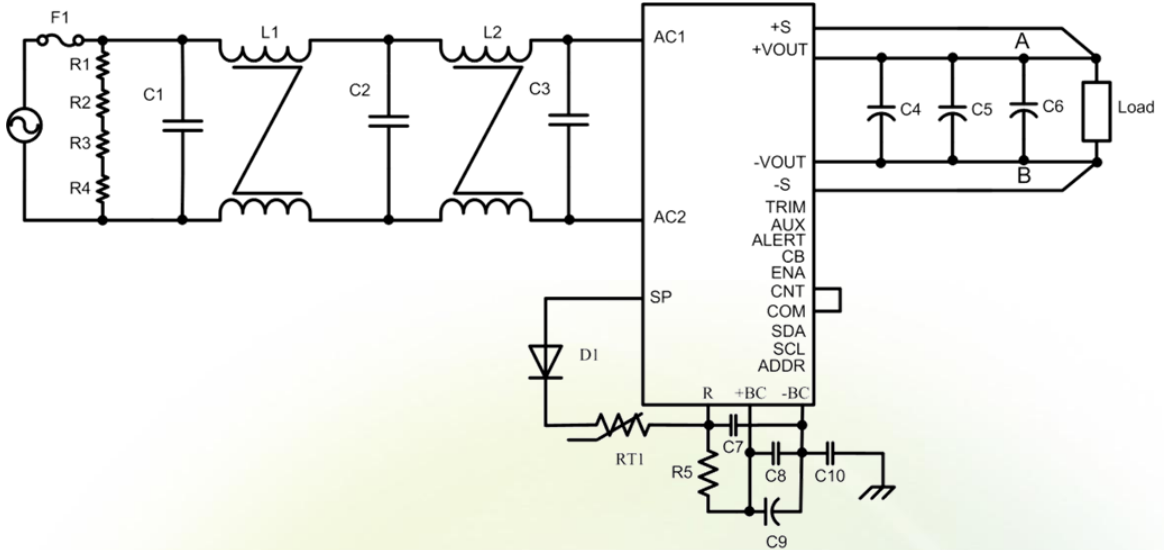

Figure 5: Test set-up diagram

- F1: 15 A, 250 V AC
- C1, C3: The 1 $\mu\text{F}/275$ V AC film capacitor is recommended.
- C2: The 0.68 $\mu\text{F}/275$ V AC film capacitor is recommended.
- C4, C5, C6: The 470 $\mu\text{F}/63$ V low ESR aluminum electrolytic capacitor is recommended.
- C7, C8: The 1.5 $\mu\text{F}/450$ V film capacitor is recommended.
- C9: The 390 $\mu\text{F}/450$ V long life (5000 h) aluminum electrolytic capacitor is recommended.
- C10: The 2200 pF capacitor is recommended.
- L1, L2: 3.5 mH
- R1, R2, R3, R4: 100 k Ω /0.25 W resistor
- R5: Cement resistor 75 Ω /5 W
- RT1: Negative Temperature Coefficient (NTC) resistor 1 Ω
- D1: 1 kV/3 A

NOTE

Points A and B, which are for testing the output voltage ripple, are 25 mm (0.98 in.) away from the $V_{\text{out}(+)}$ pin and the $V_{\text{out}(-)}$ pin.

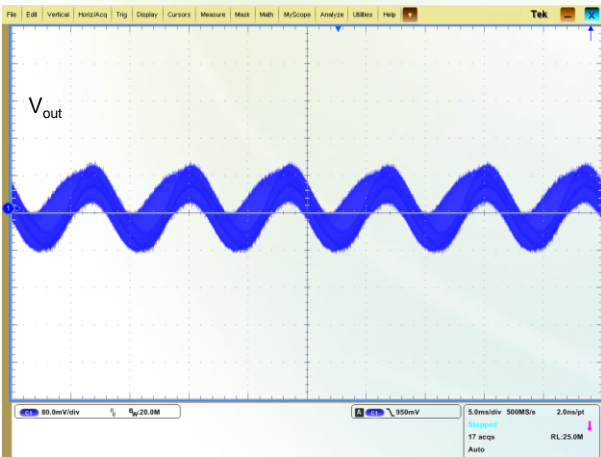

Figure 6: Output voltage ripple
(For point AB in the test set-up diagram,
 $V_{\text{in}} = 110$ V AC, $V_{\text{out}} = 28$ V, $I_{\text{out}} = 18$ A)

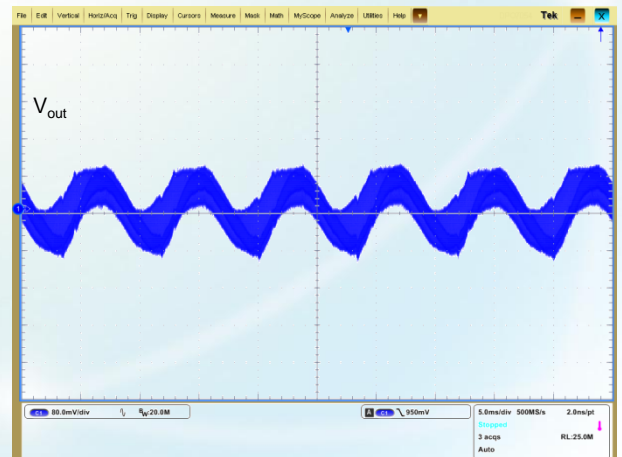

Figure 7: Output voltage ripple
(For point AB in the test set-up diagram,
 $V_{\text{in}} = 220$ V AC, $V_{\text{out}} = 28$ V, $I_{\text{out}} = 18$ A)

ADF18S28B AC-DC Converter Technical Manual V1.1

Typical Waveforms

Conditions: $T_A = 25^\circ\text{C}$.

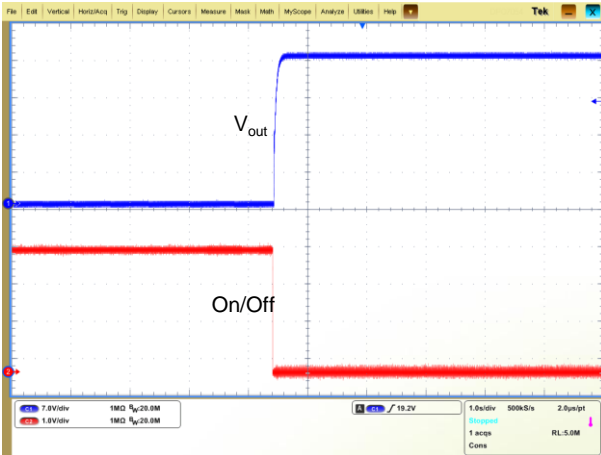

Figure 8: Startup from On/Off ($V_{in} = 110\text{ V AC}$, 100% load)

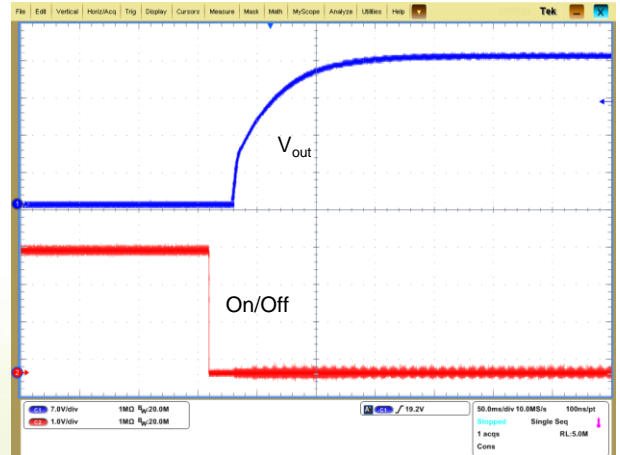

Figure 9: Startup from On/Off ($V_{in} = 110\text{ V AC}$, 100% load)

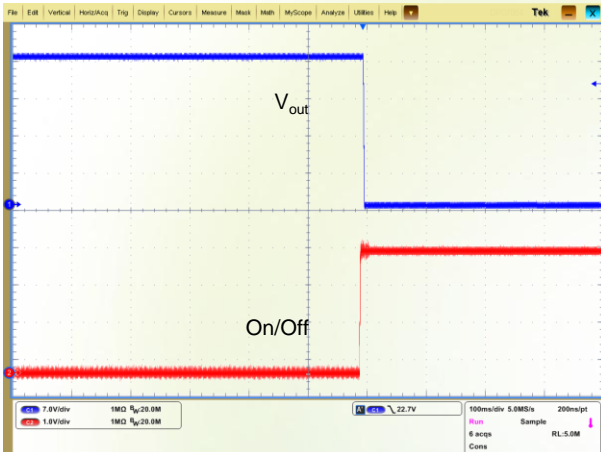

Figure 10: Shutdown from On/Off ($V_{in} = 110\text{ V AC}$, 100% load)

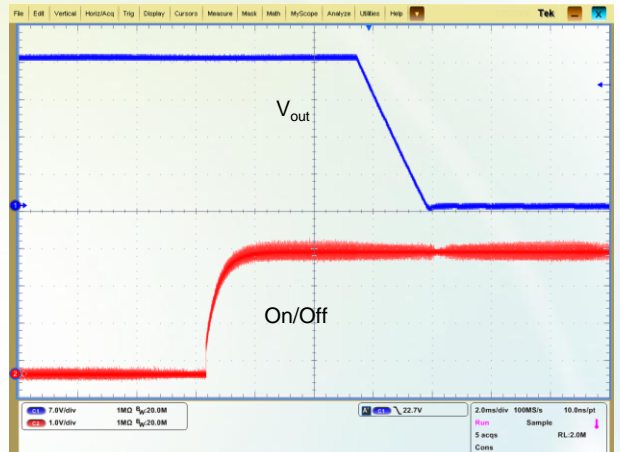

Figure 11: Shutdown from On/Off ($V_{in} = 110\text{ V AC}$, 100% load)

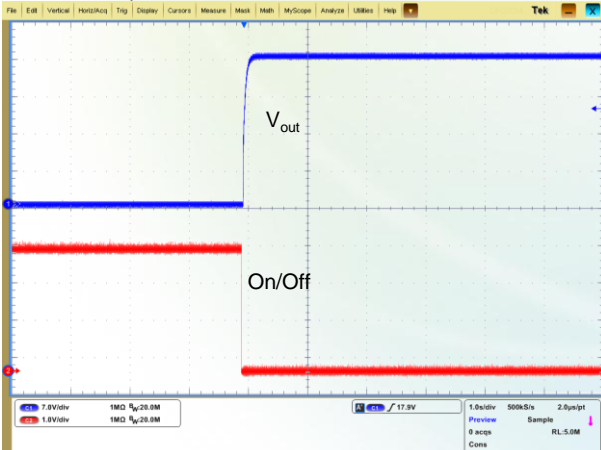

Figure 12: Startup from On/Off ($V_{in} = 220\text{ V AC}$, 100% load)

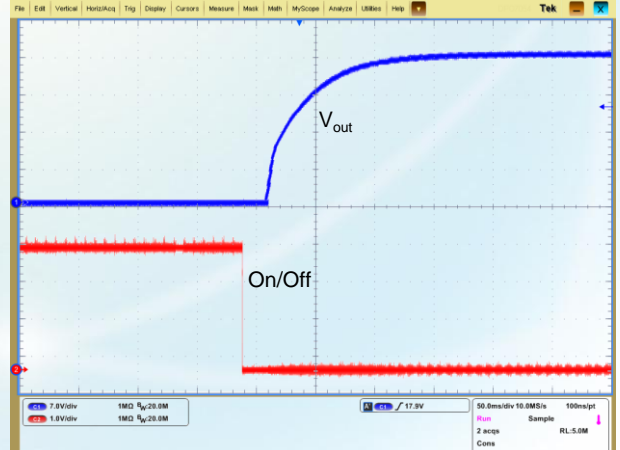

Figure 13: Startup from On/Off ($V_{in} = 220\text{ V AC}$, 100% load)

ADF18S28B AC-DC Converter Technical Manual V1.1

Typical Waveforms

Conditions: $T_A = 25^\circ\text{C}$.

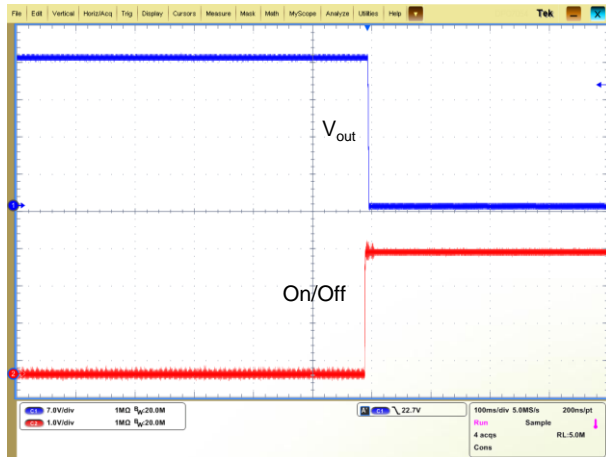

Figure 14: Shutdown from On/Off ($V_{in} = 220\text{ V AC}$, 100% load)

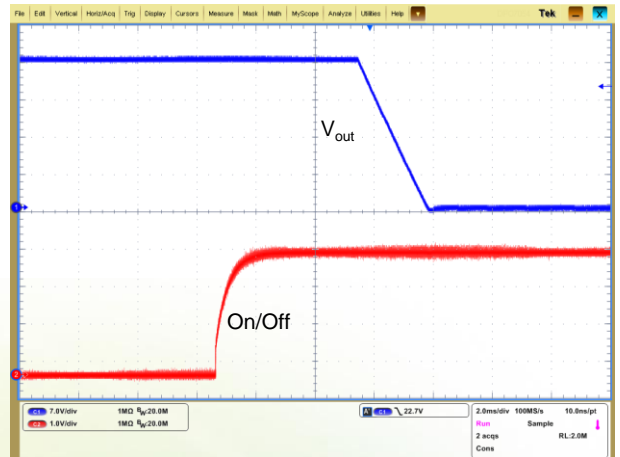

Figure 15: Shutdown from On/Off ($V_{in} = 220\text{ V AC}$, 100% load)

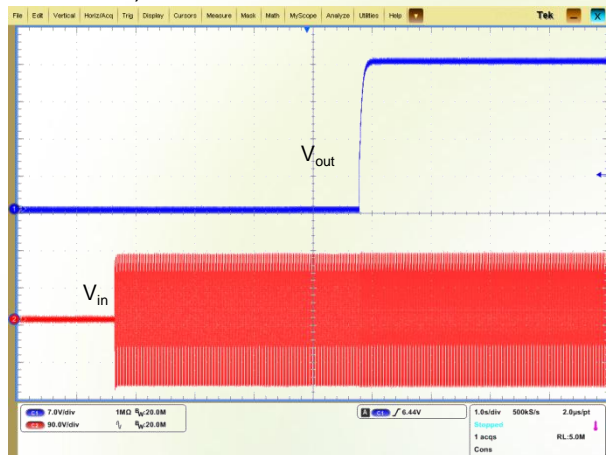

Figure 16: Startup by power on ($V_{in} = 110\text{ V AC}$, 100% load)

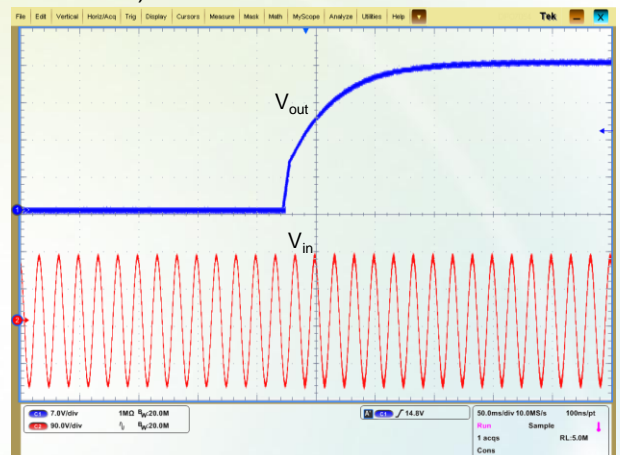

Figure 17: Startup by power on ($V_{in} = 110\text{ V AC}$, 100% load)

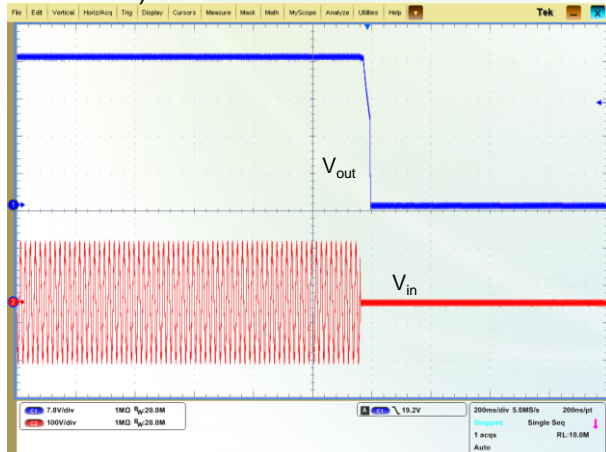

Figure 18: Shutdown by power off ($V_{in} = 110\text{ V AC}$, 100% load)

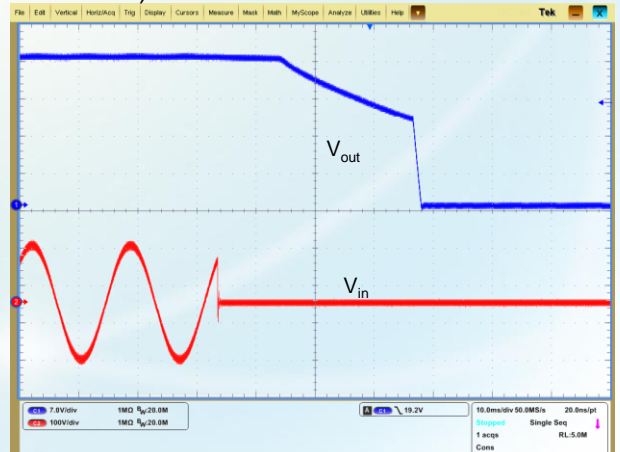

Figure 19: Shutdown by power off ($V_{in} = 110\text{ V AC}$, 100% load)

ADF18S28B

AC-DC Converter Technical Manual V1.1

Typical Waveforms

Conditions: $T_A = 25^\circ\text{C}$.

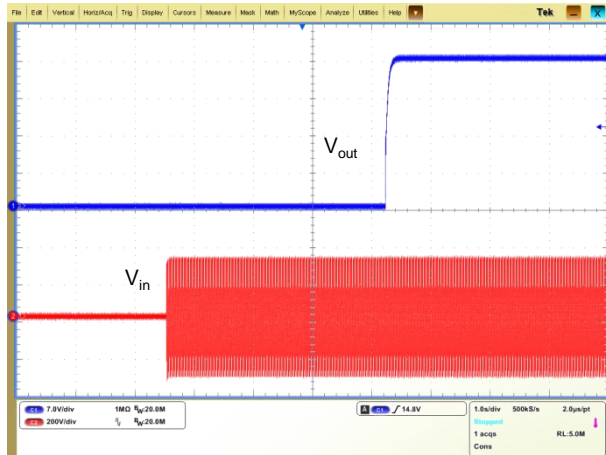

Figure 20: Startup by power on ($V_{in} = 220\text{ V AC}$, 100% load)

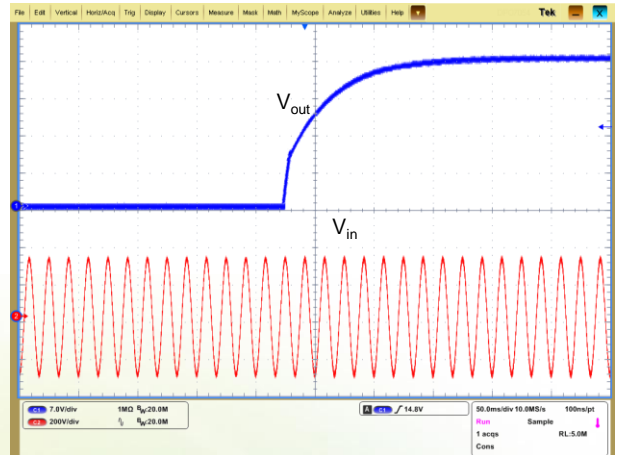

Figure 21: Startup by power on ($V_{in} = 220\text{ V AC}$, 100% load)

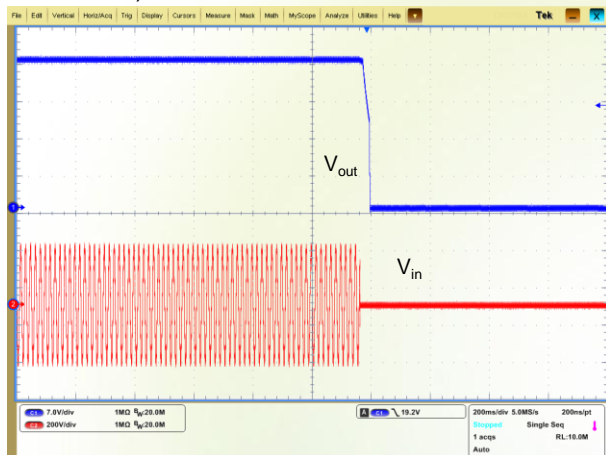

Figure 22: Shutdown by power off ($V_{in} = 220\text{ V AC}$, 100% load)

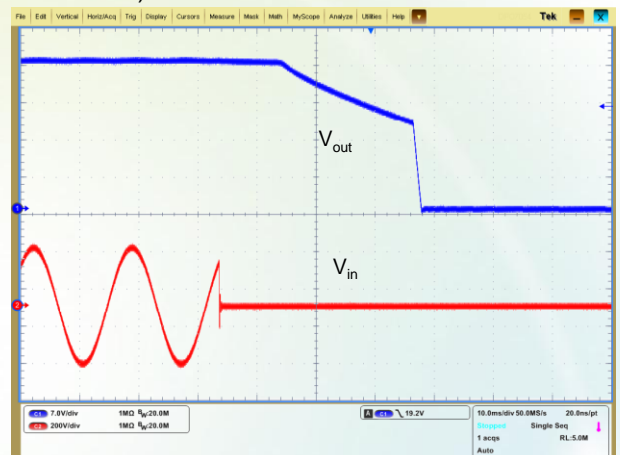

Figure 23: Shutdown by power off ($V_{in} = 220\text{ V AC}$, 100% load)

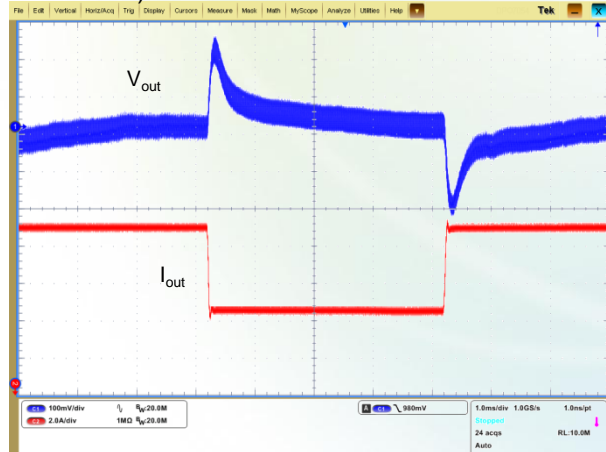

Figure 24: Output voltage dynamic response ($V_{in} = 110\text{ V AC}$, load: 50% - 25% - 50%, $di/dt = 0.1\text{ A}/\mu\text{s}$)

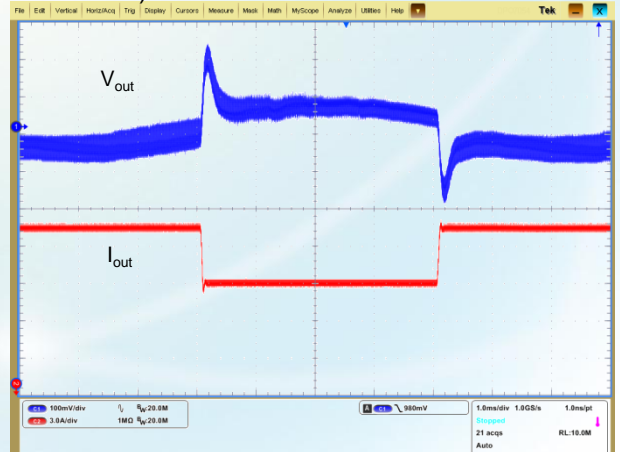

Figure 25: Output voltage dynamic response ($V_{in} = 110\text{ V AC}$, load: 75% - 50% - 75%, $di/dt = 0.1\text{ A}/\mu\text{s}$)

ADF18S28B

AC-DC Converter Technical Manual V1.1

Typical Waveforms

Conditions: $T_A = 25^\circ\text{C}$.

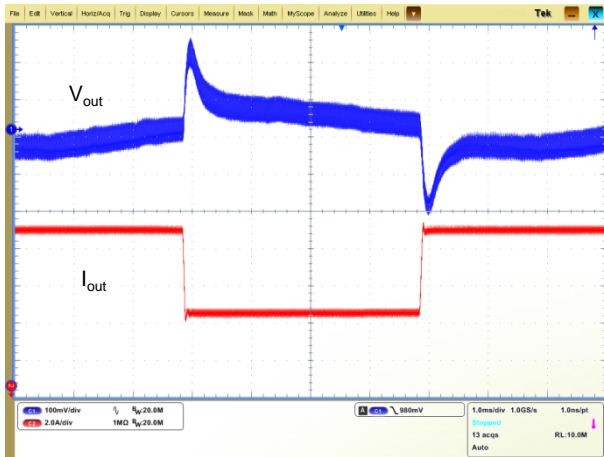

Figure 26: Output voltage dynamic response ($V_{in} = 220\text{ V AC}$, load: 50% - 25% - 50%, $di/dt = 0.1\text{ A}/\mu\text{s}$)

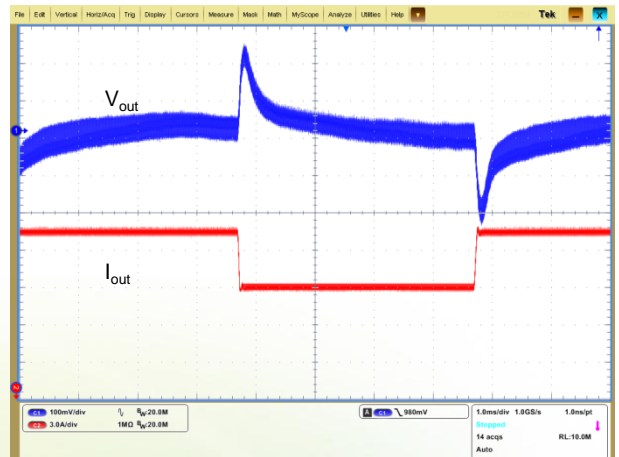

Figure 27: Output voltage dynamic response ($V_{in} = 220\text{ V AC}$, load: 75% - 50% - 75%, $di/dt = 0.1\text{ A}/\mu\text{s}$)

ADF18S28B

AC-DC Converter Technical Manual V1.1

Typical Circuit Application

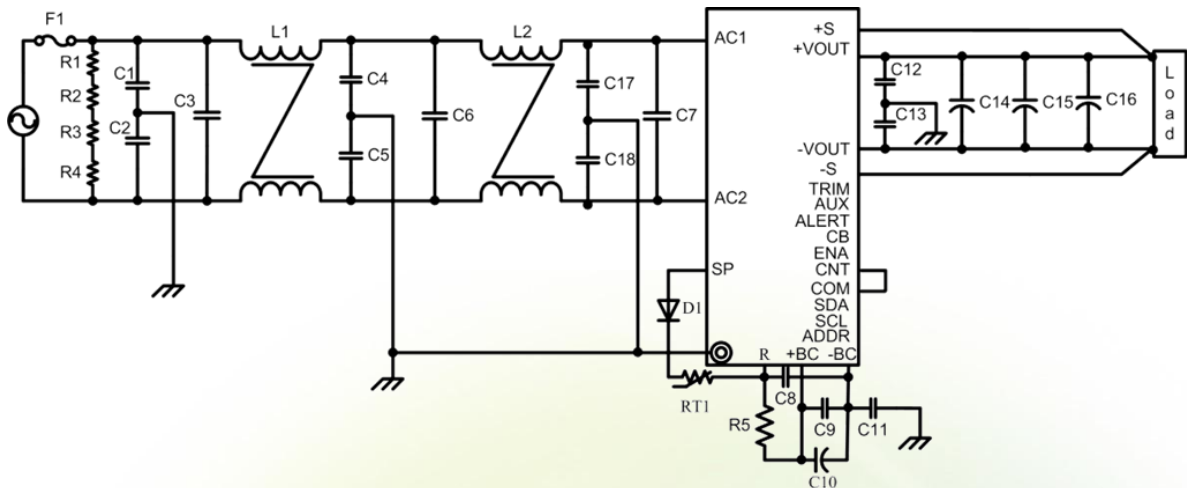

Figure 28: Typical circuit application

R1, R2, R3, R4: 0.25 W, 100 k Ω
F1: 15 A, 250 V AC

L1, L2: 3.5 mH
C1, C2: Ceramic capacitor, 1 nF, 250 V
C3, C7: Film capacitor, 1 μ F, 275 V AC
C4, C5: 10 nF, 250 V AC
C6: Film capacitor, 0.68 μ F, 275 V AC
C8, C9: Film capacitor, 1.5 μ F, 450 V
C10: Long life (5000 h) aluminum electrolytic capacitor, 390 μ F, 450 V
(Recommended product model: ELXS451VSN391MR50S NCC.)
C11: 2200 pF
C12, C13: 100 nF, 1 kV
C14, C15, C16: Low ESR aluminum electrolytic capacitor, 470 μ F, 63 V
(Recommended product model: EKY-630ELL471MK25S NCC.)
C17, C18: 1 nF, 250 V

D1: 1 kV, 3 A
R5: Cement resistor, 5 W, 75 Ω
RT1: Negative Temperature Coefficient (NTC) resistor 1 Ω

NOTE

C10, C14, C15, C16: When the temperature is lower than -25°C, double the recommended capacitor.

Remote Sense

This function is used to compensate for voltage drops on R_w . The +S, -S, $V_{out}(+)$, and $V_{out}(-)$ terminals should meet the following requirements:

$$\begin{aligned} [V_{out}(+) - (+S)] &\leq 5\%V_{out} \\ [(-S) - V_{out}(-)] &\leq 0.5 V \end{aligned}$$

(V_{out} is the rated output voltage. $20 V \leq [V_{out}(+) - V_{out}(-)] \leq 32 V$)

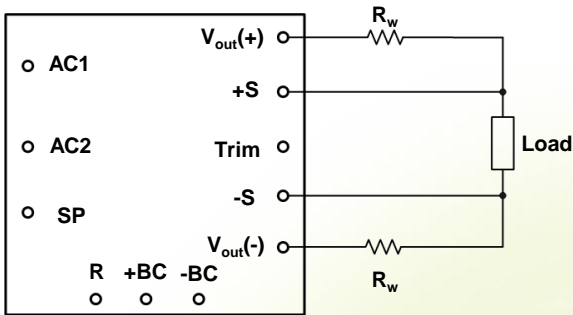

Figure 29: Configuration diagram for remote sense

R_w indicates the line impedance between the output terminal and the load.

If the remote sense function is disabled, the +S terminal directly connects to the $V_{out}(+)$ terminal and the -S terminal directly connects to the $V_{out}(-)$ terminal.

Output Voltage Trim

The output voltage can be adjusted according to the trim range specification by using the Trim pin.

Trim Up

The output voltage can be increased by installing an external resistor between the Trim pin and the +S pin.

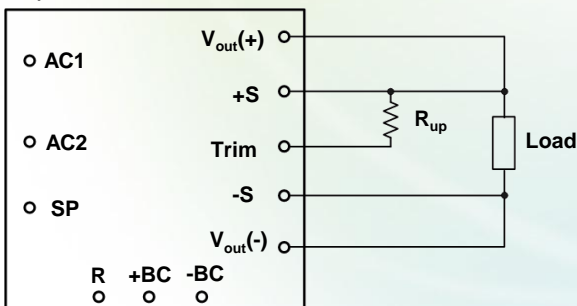

Figure 30: Configuration diagram for Trim up

The relationship between R_{up} and V_{out} :

$$R_{up} = \frac{26550 \times V_{out}}{V_{out} - 28} - 3300(\Omega)$$

Trim Down

The output voltage can be decreased by installing an external resistor between the Trim pin and the -S pin.

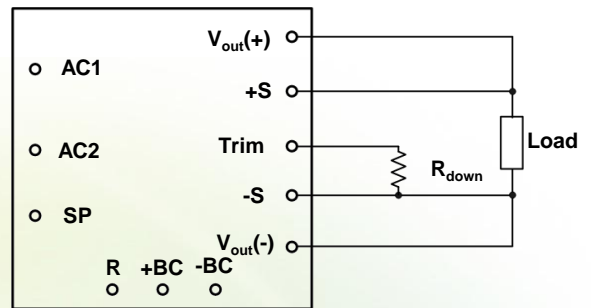

Figure 31: Configuration diagram for Trim down

The relationship between R_{down} and V_{out} :

$$R_{down} = \frac{2000 \times V_{out}}{28 - V_{out}} - 3300(\Omega)$$

NOTE

1. If the Trim pin is not used, it should be left open.
2. When the output voltage adjustment is used, be sure not to exceed the output voltage range; otherwise, the protection function will be activated.
3. Ensure that the actual output power does not exceed the maximum output power when raising the voltage.

Enable (ENA)

Enable signal means that the output voltage of the inverter is normal and can supply power for load at the second side (Maximum sink current is 10 mA and maximum applied voltage is 75 V). When output voltage goes over 15 V at start up, ENA signal is low level; when output voltage drops below 13 V or input power failure, ENA signal is high resistance. The logic of Enable is as following:

Logic Enable	ENA	Output Voltage
Negative Logic	High resistance	$\leq 13 V$ or Input fault, input power failure
	Low resistance	$> 15 V$

ADF18S28B

AC-DC Converter Technical Manual V1.1

Enable (ENA)

The enable signal is pulled up to the AUX by a 10 kΩ external resistor, indicated by an LED. The recommended circuit diagram of enable is shown in Figure 32:

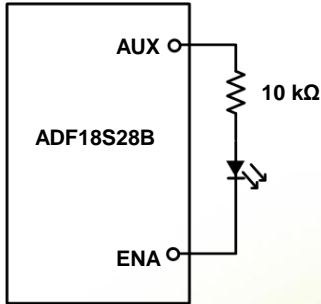

Figure 32: Recommended circuit diagram of Enable

Remote CNT (On/Off)

Remote control function realizes output enable or disable without turning the input power supply on and off. When this output On/Off control is not used, be sure to short CNT to COM terminal. The logic of On/Off are as following:

Logic Enable	On/Off	28 V Output
Negative Logic	Low level	On
	High level or left open	Off

The configuration diagram of CNT (On/Off) is as following:

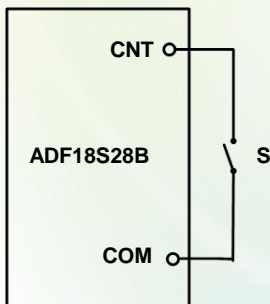

Figure 33: Configuration diagram of CNT (On/Off) signal

Auxiliary Power Supply (AUX)

The AUX terminal supplies auxiliary power for an external circuit with a typical output voltage of 12 V. Be careful not to short-circuit the AUX terminal and other terminals or the power module; otherwise, the power module would be damaged. Do not connect the AUX terminal if you do not need to supply power to any external circuit.

Parallel Operation (CB terminal)

When several power modules are used in parallel, an output current can be equally drawn from each one by connecting the CB terminals of all modules. A maximum of two units of the same module can be connected. The output power of two modules connected in parallel is equal to or less than 90% of the power of two fully loaded modules.

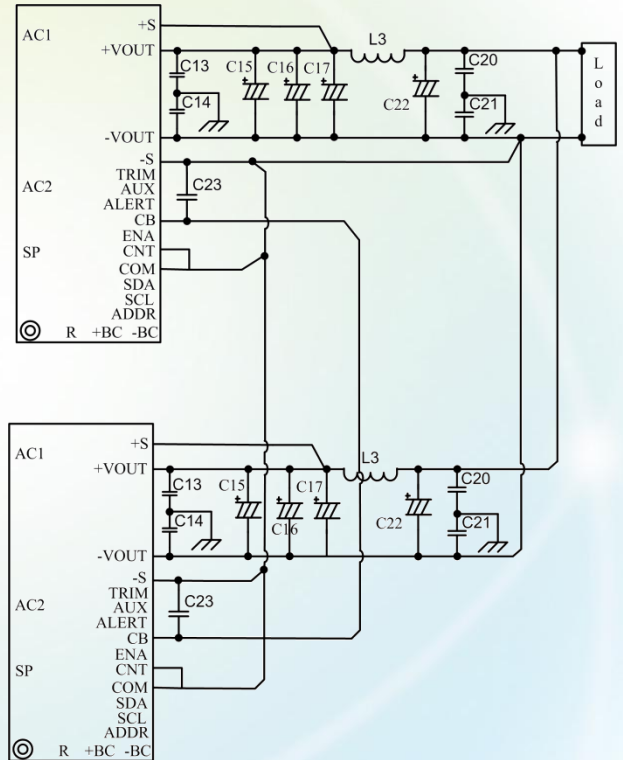

Figure 34: The circuit for parallel operation

NOTE

1. L3: High frequency inductor 0.3 μH
2. C22: Aluminum electrolytic capacitor 63 V, 470 μF
3. C23: 1 μF, 16 V
4. Other capacitor parameters see **EMC**.

PMBus Communication

The converter communicates with the system over the PMBus. PMBus address with the following table:

R (ADDR pull-down resistor)	Address
Open	Invalid
200 kΩ	0x5F
174 kΩ	0x5E
150 kΩ	0x5D
124 kΩ	0x5C
100 kΩ	0x5B
75 kΩ	0x5A
49.9 kΩ	0x59
24.9 kΩ	0x58
Ground	Invalid

Bit is as follows:

Bit	7	6	5	4	3	2	1	0
-	Address							Read/Write

Monitor and Faults

The converter communicates with the system over the PMBus. The ADF18S28B provides the following monitoring and communication functions and fault detection functions:

Monitoring functions:

- Module information
- Input voltage
- Input power
- Output voltage
- Output power
- Baseplate temperature
- CNT (On/Off)

Faults detection functions:

- Reports faults for input faults
- Reports faults for output overvoltage
- Reports faults for output overcurrent
- Reports faults for baseplate overtemperature

SCL and SDA

The SCL and SDA signal has an internal pull-up resistor, connected to the communication bus through the fault isolation circuit. Figure 35 shows the SCL and SDA connection diagram.

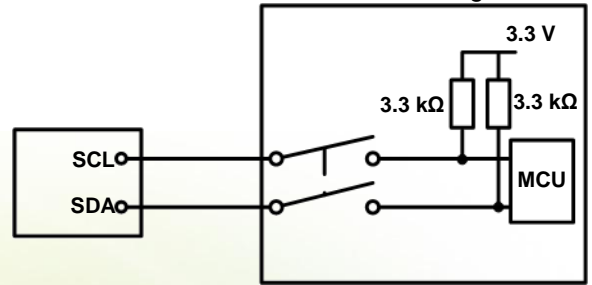

Figure 35: SCL and SDA connection diagram

PMBus Timing Diagram

The power supply supports both 100 kHz and 400 kHz clock rates, and 100 kHz is the default one. T_{set} is the duration for which SDA keeps its value unchanged before SCL increases. T_{hold} is the duration for which SDA keeps its value unchanged after SCL decreases. The communication will fail if the time is not consistent with the specifications.

The following table lists the timing characteristics of the PMBus communications interface and Figure 36 shows the timing diagram of the interface.

Parameter	Min.	Typ.	Max.	Unit
Logic Input Low (V_{IL})	-	-	1.1	V
Logic Input High (V_{IH})	2.1	-	-	V
Logic output Low (V_{OL})	-	-	0.25	V
Logic output High (V_{OH})	2.7	-	-	V
PMBus setting-up time	100	-	-	ns
PMBus holding time	0	-	-	ns
Clock/data fall time (t_f)	20+	-	300	ns
Clock/data rise time (t_r)	0.1Cb	-	300	ns
Total capacitance of one bus line (C_b)	-	-	400	pF

ADF18S28B

AC-DC Converter Technical Manual V1.1

PMBus Communication

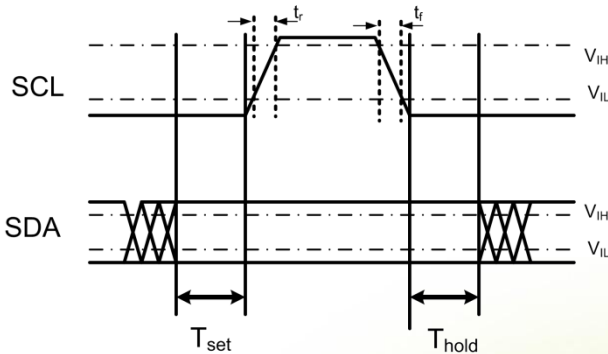

Figure 36: PMBus timing diagram

PMBus Commands

Hex Code	Command Name	Data Type	Data Byte	Data Format
Control commands				
01h	OPERATION	Read/Write Byte	1	-
03h	CLEAR_FAULTS	Send Byte	0	-
Output commands				
20h	VOUT_MODE	Read Byte	1	-
21h	VOUT_COMMAND	Read/Write Word	2	Linear 16
Alarm commands				
51h	OT_WARN_LIMIT	Read/Write Word	2	Linear 11
Status commands				
79h	STATUS_WORD	Read Word	2	-
Monitoring commands				
88h	READ_VIN	Read Word	2	Linear 11
8Bh	READ_VOUT	Read Word	2	Linear 16
8Ch	READ_IOUT	Read Word	2	Linear 11
8Dh	READ_TEMPERATURE_1	Read Word	2	Linear 11
96h	READ_POUT	Read Word	2	Linear 11

Hex Code	Command Name	Data Type	Data Byte	Data Format
Monitoring commands				
97h	READ_PIN	Read Word	2	Linear 11
98h	PMBUS_REVISION	Read Byte	1	-
E9h	MFR_STATUS_WORD	Read Word	2	-
ECh	MFR_WRITE_SYSTIME	Write Block	4	Time: S Low byte in the former, the high byte in the post
EFh	MFR_READ_LAST_ACDCROP_TIME	Read Block	8	
F6h	WRITE_STANDBY	Write Byte	1	0x20: RESET 0x00: Standby

Data Format

●Linear 11 Data Format

The linear data format is a two byte value with an 11-bit, two's complement mantissa and a 5-bit, two's complement exponent or scaling factor, as shown in the following Figure 37.

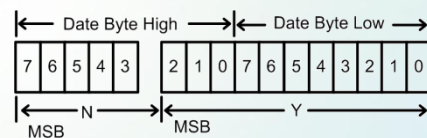

Figure 37: Linear 11 Data Format

The relationship between the N, Y, and actual value is given by the following equation:

$$X = Y \times 2^N$$

where

X is the value

Y is the 11-bit, two's complement mantissa.

N is the 5-bit, two's complement exponent.

●VOUT Data Format

Commands related to output voltage are the VOUT_COMMAND, VOUT_MODE and READ_VOUT. They are unsigned integers using the Linear 16 formats, as shown in the following Figure 38.

ADF18S28B

AC-DC Converter Technical Manual V1.1

PMBus Communication

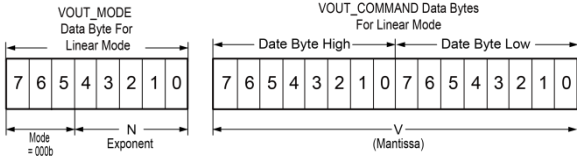

Figure 38: VOUT Data Format

The power supply is not required to support the VOUT_COMMAND, but must adhere to the VOUT data format. The output voltage is calculated as follows:

$$\text{Voltage} = V \times 2^N$$

where

Voltage is the output voltage value.

V is the 16-bit unsigned integer.

N is the 5-bit signed integer (two's complement).

Command Descriptions

OPERATION (01h): By default the Power supply is turned ON at power up as long as Enable is active low.

The Operation command is used to turn the Power Supply ON or OFF via the PMBus. The data byte below follows the OPERATION command.

Function	Data Byte
ON	0x80
RESET	0x00
OFF	0x55

To RESET the power supply cycle the power supply OFF, wait at least 10 seconds, and then turn ON. All alarms and shutdowns are cleared during a restart.

CLEAR_FAULTS (03h): This command clears the latch fault bits.

VOUT_MODE (20h): This command is used to determine the data type and parameters using PMBus command.

VOUT_COMMAND (21h): This command is used to change the output voltage of the power supply. The default value is 28 V. Voltage margin range: 20 V - 32 V.

STATUS_WORD (79h): Module fault information, latch off.

Bit	Fault Name	Fault Definition
b15 - b6	-	-
b5	VOUT_OV	1 - Overvoltage 0 - Normal
b4	IOUT_OC	1 - Overcurrent 0 - Normal
b3	-	-
b2	OVER_TEMP ERATURE	1 - Overtemperature 0 - Normal
b0, b1	-	-

MFR_STATUS_WORD (E9h): Power state. Don't latch.

Bit	Fault Name	Fault Definition
b15 - b1	-	-
b0	REMOTE ON/OFF	1 - OFF 0 - ON

MFR_WRITE_SYSTIME (ECh): As the converter does not have a time chip. The system uses the ECh command to deliver the system time to the converter. The converter then runs based on the delivered system time in unit of seconds. To ensure time accuracy, it is recommended that the system synchronize time to the converter every 10 minutes. The MFR_WRITE_SYSTIME command format is shown in Figure 39:

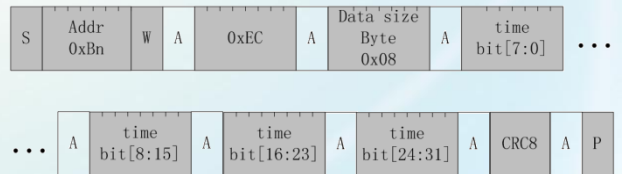

Figure 39: MFR_WRITE_SYSTIME command format



NOTE

S: Start Condition; R: Read bit value of 1; W: Write bit value of 0; A: Acknowledge bit, may be ACK or NACK; P: Stop Condition.

PMBus Communication

MFR_READ_LAST_ACDROP_TIME (EFh): The converter can record the last disconnection time. It reads the time using the EFh command. The EFh data format is shown in the figure. The time occupies four bytes and the high-order byte takes precedence over the low-order byte during transmission.

The MFR_READ_LAST_ACDROP_TIME command format is shown in Figure 40:

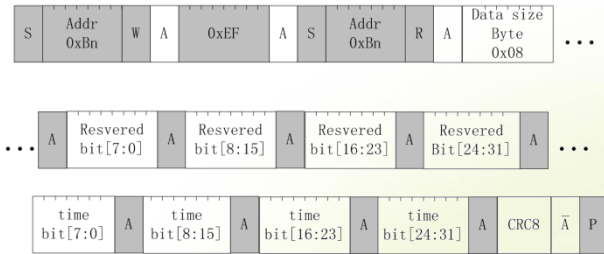

Figure 40: MFR_READ_LAST_ACDROP_TIME command format

The converter uses 8-bit cyclic redundancy check (CRC). The generator polynomial is $C(x) = x^8 + x^2 + x + 1$, or 0b10000111 if expressed in binary form.

The power supply is compliant with the Power Management Bus (PMBus) Protocol Specification rev1.2 requirements. For details about the PMBus Commands, see the **PMBus Protocol Specification rev1.2**.

Input Overvoltage Protection

The converter will shut down after the input voltage exceeds the input overvoltage protection threshold for shutdown. The converter will start to work again after the input voltage reaches the input overvoltage recovery threshold for startup. For the Hysteresis, see the **Protection characteristics**.

Input Undervoltage Protection

The converter will shut down after the input voltage drops below the undervoltage protection threshold for shutdown. The converter will start to work again after the input voltage reaches the input undervoltage recovery threshold for startup. For the Hysteresis, see the **Protection characteristics**.

Output Overvoltage Protection

When the voltage directly across the output pins exceeds the output overvoltage protection threshold, the converter will enter hiccup mode. If the converter experiences five or more times of overvoltage due to an internal fault within 20s, the converter locks out. You need to restart the converter to unlock it. It must be more than 20s since input source power-off to power-on. The converter dynamic overvoltage does not exceed 39 V.

Output Overcurrent Protection

When the output current exceeds the output overcurrent protection threshold, the converter will enter a hiccup mode. When the fault condition is removed, the converter will automatically restart.

Overtemperature Protection

A temperature sensor on the converter senses the average temperature of the module. It protects the converter from being damaged at high temperatures. When the temperature exceeds the overtemperature protection threshold, the output will shut down. If the temperature falls by or below the overtemperature protection recovery threshold more than 5 minutes after the converter shuts down, the output recovers. Note that the sensor does not sense the temperature within 5 minutes after the output shuts down. Therefore, even if the temperature falls to a very low level within 5 minutes after the output shuts down, there is still no output.

Cooling Characteristics

When the power module is running, the temperature of the baseplate must not exceed 90°C. The power module supports natural cooling and fan cooling. Customers can select heat sink models depending on the onsite conditions.

ADF18S28B

AC-DC Converter Technical Manual V1.1

EMC

Figure 41 shows the EMC test set-up diagram. The acceptance standard is required as the conducted emission limits of CISPR22 Class B with 6 dB margin. The operation with Surges/Impulse Current, the level of Surge is CM/DM 6 kV/6 kV 2 Ω (1.2/50), and the level of Impulse Current is CM/DM 5 kA/5 kA (8/20).

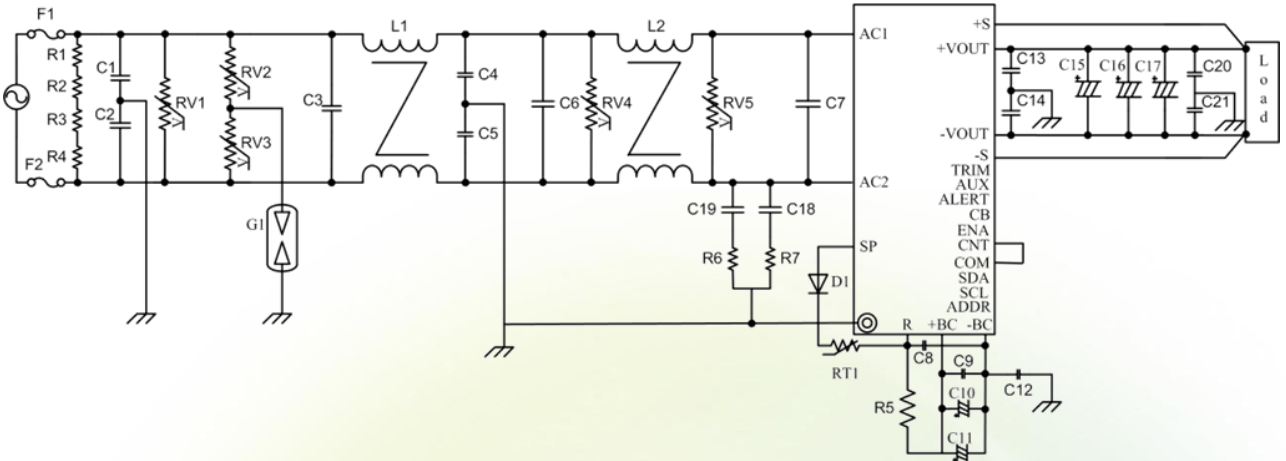

Figure 41: EMC test set-up diagram

R1, R2, R3, R4: 0.25 W, 100 k Ω
RV1: 620 V - 385 V - 12 kA
RV2, RV3: 750 V - 460 V - 12 kA
RV4: 620 V - 385 V - 12 kA
RV5: 620 V - 385 V - 4.5 kA

L1, L2: 3.5 mH, 220 V, 10 A
C1, C2: Ceramic capacitor, 1 nF, 250 V
C3, C7: Film capacitor, 1 μ F, 275 V AC
C4, C5: 0.01 μ F, 250 V
C6: Film capacitor, 0.68 μ F, 275 V AC
C8, C9: Film capacitor, 1.5 μ F, 450 V
C10, C11: Long life (5000 h) aluminum electrolytic capacitor, 390 μ F, 450 V
(Recommended product model: ELXS451VSN391MR50S NCC.)

C12: 2200 pF
C13, C14: 100 nF, 1 kV
C15, C16, C17: Low ESR aluminum electrolytic capacitor, 470 μ F, 63 V
(Recommended product model: EKY-630ELL471MK25S NCC.)

C18, C19: 1 nF, 250 V
C20, C21: 22 nF, 1 kV

D1: 1 kV, 3 A
R5: Cement resistor, 5 W, 75 Ω
R6, R7: 0.25 W, 22 Ω
RT1: Negative Temperature Coefficient (NTC) resistor 1 Ω
G1: 10 kA, 1.5 kV
F1, F2: 15 A, 250 V AC

NOTE

C10, C11, C15, C16, C17: When the temperature is lower than -25°C, double the recommended capacitor.

ADF18S28B

AC-DC Converter Technical Manual V1.1

Qualification Testing

Parameter	Units	Condition
High Accelerated Life Test (HALT)	6	Low temperature limit: -60°C; high temperature limit: 110°C; vibration limit: 40 G; temperature slope: 40°C per minute; vibration frequency range: 10 Hz - 10000 Hz
Temperature Humidity Bias (THB)	12	Maximum input voltage; 85°C; 85% RH; 1000 operating hours under lowest load power
High Temperature Operation Bias (HTOB)	12	Rated input voltage; air flow: 0.5 m/s (100 LFM) to 5 m/s (1000 LFM); ambient temperature between +45°C and +55°C; 1000 operating hours; 50% to 80% load
Power and Temperature Cycling Test (PTC)	12	Rated input voltage; air flow: 0.5 m/s (100 LFM) to 5 m/s (1000 LFM); ambient temperature between -40°C and +85°C; 1000 operating hours; 50% load; temperature slope: 15°C per minute; dwell time: 22 minutes

Thermal Consideration

Thermal Test Point

Sufficient airflow should be provided to ensure reliable operating of the converter. Therefore, thermal components are mounted on the top surface of the converter to dissipate heat to the surrounding environment by conduction, convection and radiation. Proper airflow can be verified by measuring the temperature at the middle of the baseplate.

Middle of the baseplate



Figure 42: Thermal test point

Power Dissipation

The converter power dissipation is calculated based on efficiency. The following formula reflects the relationship between the consumed power (P_d), efficiency (η), and output power (P_o): $P_d = P_o(1-\eta)/\eta$

ADF18S28B

AC-DC Converter Technical Manual V1.1

Mechanical Consideration

Installation

Although the converter can be mounted in any direction, free airflow must be taken.

Soldering

The converter is compatible with standard wave soldering or hand soldering. No reflow soldering is allowed.

1. For wave soldering, the temperature on converter is specified to maximum 260°C for maximum 7 seconds.
2. For hand soldering, the iron temperature should be maintained at 350°C to 420°C, and applied to the converter pins for less than 10 seconds.

The converter can be rinsed using the isopropyl alcohol (IPA) solvent or other proper solvents.

HUAWEI TECHNOLOGIES CO., LTD.
Huawei Industrial Base Bantian Longgang
Shenzhen 518129
People's Republic of China
www.huawei.com