

- NOTES:
- MATERIAL:
 - HOUSING: PA9T (KURARU GN2330), UL94 V-0; COLOR: BLACK
 - DUMMY CARD: LCP (E488i)
 - CONTACT: PHOSPHOR BRONZE, C5191-H t=0.25mm.
 - FINISH:
 - CONTACT:
 - SELECTIVE GOLD PLATING ON CONTACT AREA.
 - 100u" MIN. MATTE-TIN PLATING ON SOLDER TAIL AREA.
 - 50u" MIN. NICKEL UNDERPLATING OVERALL.
 - "⌀" IS MAJOR DIMENSION FOR QC
 - "Ⓢ" SHOWS FAI MEASUREMENT ITEMS.
 - PRODUCT SPEC: PS-3GIO-01
 - PACKAGING SPEC: 318304001
 - PART NO.

3157 - 10X0XD

PCI EXPRESS Series No. _____ Packing Options
 HSG Color _____ D: Tray With Dummy Card
 0: Natural No. of Pins
 1: Black 0: 36P
 Contact Plating _____ 1: 64P
 0: 30u" Gold 2: 98P
 1: 15u" Gold 3: 164P
 2: 1u" Gold

DIMENSIONS				
POSITION	A ±0.20	B $+0.15/-0.05$	C ±0.15	D $+0.00/-0.15$
36	25.00	7.65	6	23
64	39.00	21.65	20	37
98	56.00	38.65	37	54
164	89.00	71.65	70	87

				TOLERANCE	
				LINEAR	ANGLES
				X.±0.30	X'±
				.X±0.20	.X'±
0		Terry	Jun,27,2012	.XX±0.15	.XX'±
REV	ECN NO.	NAME	DATE	.XXX±0.08	.XXX'±

UMax conn 东莞市友贸实业有限公司
 DONGGUAN UMAXCONN ENTERPRISE LIMITED

APPD: Jason MAT'L:
 CHKD: Schumi FINISH:
 DRWN: Terry Q'TY:

TITLE: PCI EXPRESS CARD EDGE CONNECTOR STRADDLE MOUNT TYPE

PART NO. 3157-10X0XD

DWG NO. 315705001

UNITS	MM	SCALE	1 : 1	SHEET	1 OF 2	REV	0

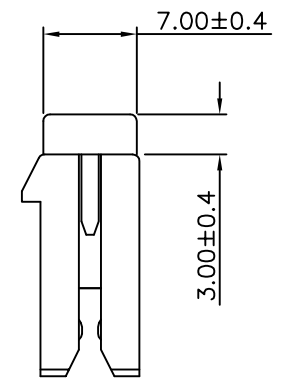
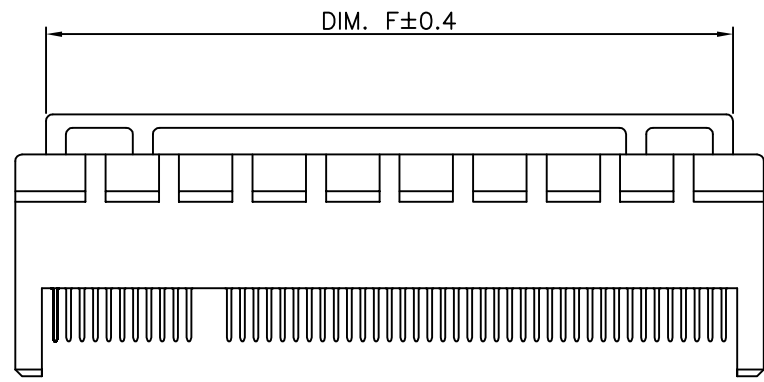
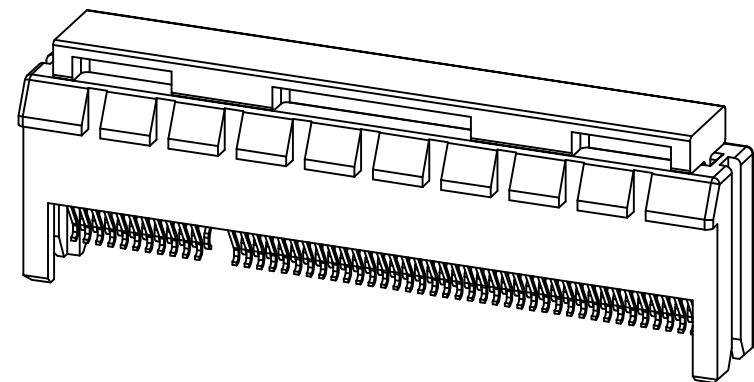
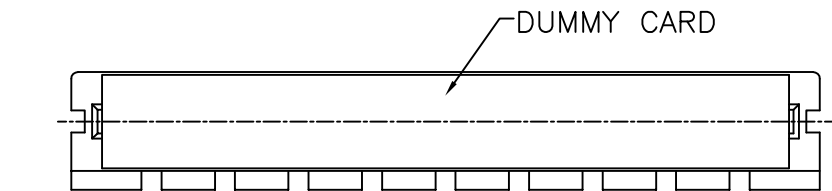

8.1	20.4
64	34.4
98	51.4
164	84.4
POSITION	DIM F

ASSEMBLY WITH CAP CONDITION

REV	SEE SHEET 1	NAME	DATE
	ECN NO.		

TOLERANCE	
LINEAR	ANGLES
X.±0.30	X'±
.X±0.20	.X'±
.XX±0.15	.XX'±
.XXX±0.08	.XXX'±

UMax conn 东莞市友贸实业有限公司
DONGGUAN UMAXCONN ENTERPRISE LIMITED

APPD: Jason MAT'L:
CHKD: Schumi FINISH:
DRWN: Terry Q'TY:

TITLE: PCI EXPRESS CARD EDGE CONNECTOR STRADDLE MOUNT TYPE

PART NO. 3157-10X0XD

DWG NO. 315705001

	UNITS	SCALE	SHEET	REV
	MM	1 : 1	2 OF 2	0