



FEATURES

- Wide operating voltage:
 - 36V ~ 57V
- Output Current
 - 5V, 2A
 - 12V, 1.1A
- Output voltage ripple: 70mV_{PP}, (5V@2A)
- High Efficiency 86% (input 48V, Load 12V@1.1A)
- Overcurrent /short circuit protection
- High reliability: designed to meet 500k hour MTBF
- Minimal space on PCB:
 - -R: 27.9 mm x 17.8 mm x 12.6mm
 - SMD: 27.9 mm x 20.6 mm x 13.3mm
- Operating temperature: -40~+85°C
- No derating to +TBD°C, inside closed box
- UL/IEC/EN60950 compliant
- RoHS Compliant available

APPLICATIONS

- IP Camera
- IP Phone
- Wireless Access Point
- Video Supervisory

Description

The **MQ7813** series of modules are designed to extract power from a conventional twisted pair Category 5 Ethernet cable, conforming to the IEEE 802.3af Power-over-Ethernet (PoE) standard. **MQ7813** focus on small-power application like IP camera, IP phone, industrial sensor, gatekeeper etc.

The **MQ7813** signature and control circuit provides the PoE compatibility signature and power classification required by the Power Sourcing Equipment (PSE) before applying up to 13W power to the port. The **MQ7813** is compatible with Class 0 to Class 3 equipment.

The high efficiency DC/DC converter operates over a wide input voltage range and provides a regulated low ripple and low noise output. The DC/DC converter also has built-in overload and short-circuit output protection.

***** **Typical Application Circuit** *****

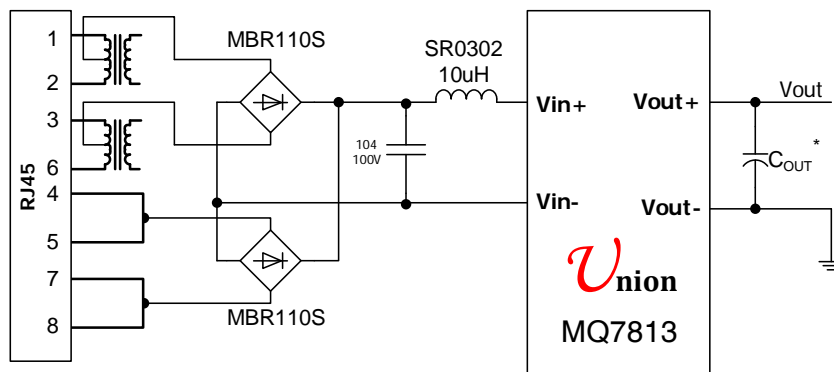

*: Refer to Typical Characteristics.

POE input power module MQ7813

Performance Specifications (at $T_a = +25^\circ\text{C}$)

Model	Input V_{IN} Range (V)	Output				Efficiency (%)
		I_{OUT} (A)	V_{out} (V)	Regulation		
				Line (%)	Load (%)	
MQ7813S050	36~57	2	5.0	1	1	83
MQ7813S120		1.1	12.0	1	1	86

Mechanical Specifications

Dimensions are in millimeters [inches]

Tolerances: x.x mm ± 0.5 mm (x.xx in ± 0.02 in); x.xx mm ± 0.25 mm (x.xxx in ± 0.01 in)

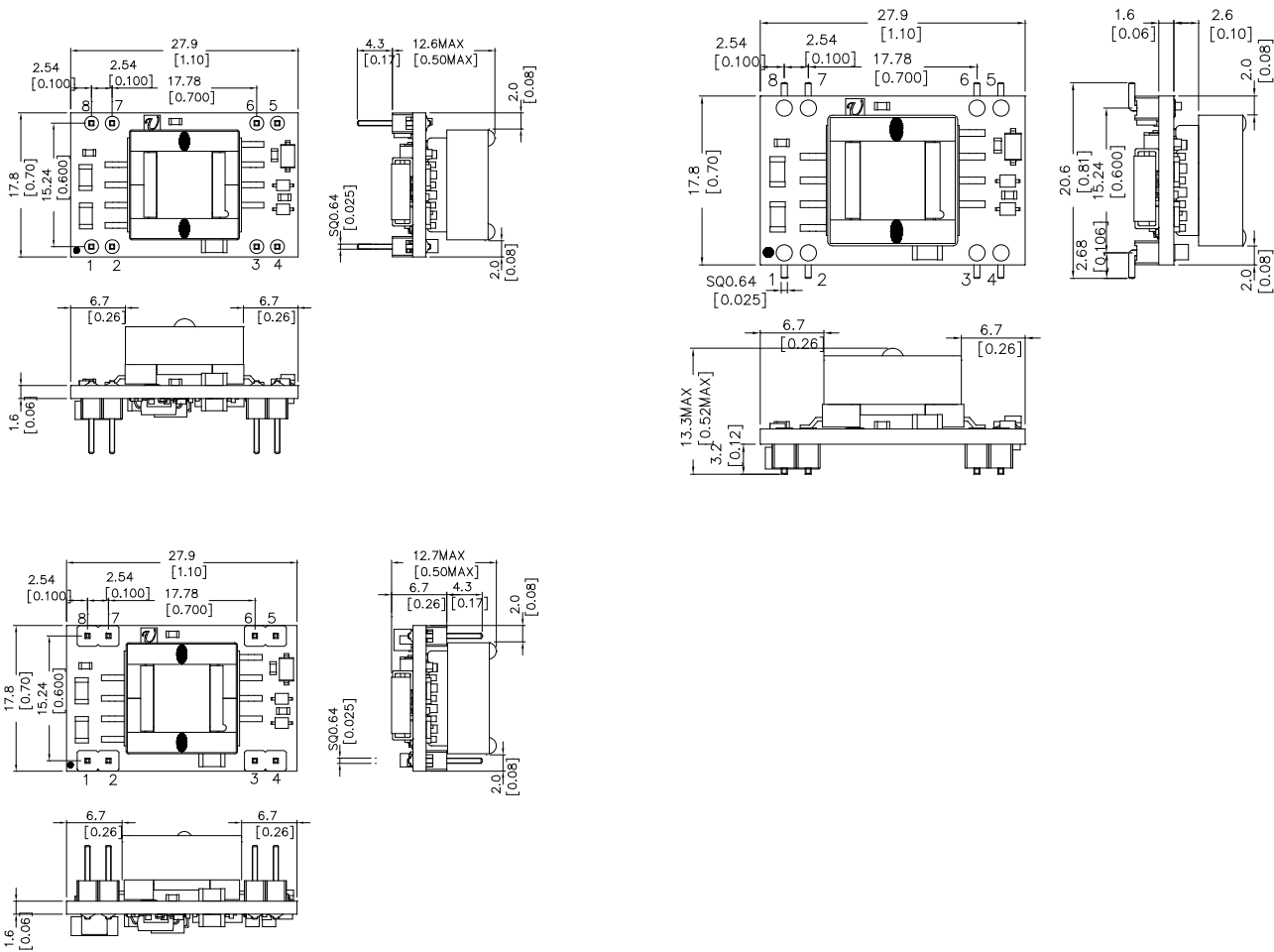

PIN	1,2	3	4	5,6	7,8
DESCRIPTION	V_{OUT+}	V_{OUT-}	TRIM	V_{IN+}	V_{IN-}

Ordering Information

MQ7813T050-BN

Union Microsystems
Power Module P/N#

Reverse pin

Default Output Voltage:
050: 5.0V
120: 12.0V

Package Type:
T: Through Hole
S: SMD

For examples:

MQ7813T120 means MQ7813 in through-hole pin configuration; output voltage is preset to 12V.

Absolute Maximum Ratings

Note: These are stress ratings. Exposure of devices to any of these conditions may adversely affect long-term reliability. Proper operation under conditions other than those listed in the Performance Specifications Table is not implied.

Parameter	Symbol	Min	Max	Unit
Input Voltage	V _{IN}	-		V
Storage Temperature	T _{STG}	-40	125	°C

MQ7813T050 Electrical Specifications: (T_A=+25°C)

Parameter	Condition	Symbol	Min	Typ.	Max	Unit
Input Voltage Range		V _{IN}	36	48	57	V
Output Current		I _o			2	A
Output Voltage Set point	100% load	ΔV _o		2		%
Temperature Regulation	T _A = T _{A.MIN} To T _{A.MAX}	-		0.2		%V _{o.SET}
Line Regulation	See each output's corresponding character figure					
Load Regulation	See each output's corresponding character figure					
Output Ripple and Noise Voltage	I _o =2A, 0~20MHz					
Transient Response	See each output's corresponding character figure					
Overcurrent Protection	48V _{in}	I _o		3.4		A
Under Voltage Lockout Trip Level	Rising V _{IN} , with 10% full load	V _{IN}		38.5	40	V
Under Voltage Lockout Trip Level	Falling V _{IN} , with 10% full load	V _{IN}		30		V
Start-up Time	2A resistive load, no external output capacitors			4		mS
Switching Frequency		F _o		275		kHz
Operating Temperature	Natural convection		-40		85	°C
Vibration	3 Axes, 5 Min Each					
	3 Axes, 6 Times Each					
MTBF					500,000	Hour

POE input power module MQ7813

MQ7813T120 Electrical Specifications: (TA=+25°C)

Parameter	Condition	Symbol	Min	Typ.	Max	Unit
Input Voltage Range		V _{IN}	36	48	57	V
Output Current		I _o			1.1	A
Output Voltage Set point	100% load	ΔV _o		2		%
Temperature Regulation	T _A = T _{A.MIN} To T _{A.MAX}	-		0.2		%V _{o.SET}
Line Regulation	See each output's corresponding character figure					
Load Regulation						
Output Ripple and Noise Voltage						
Transient Response						
Overcurrent Protection	48Vin	I _o		1.54		A
Under Voltage Lockout Trip Level	Rising V _{IN} , with 10% full load	V _{IN}		38.5	40	V
Under Voltage Lockout Trip Level	Falling V _{IN} , with 10% full load	V _{IN}		30		V
Start-up Time	1.1A resistive load, no external output capacitors			4		mS
Switching Frequency		F _o		275		kHz
Operating Temperature	Natural convection		-40		85	°C
Vibration	3 Axes, 5 Min Each					
	3 Axes, 6 Times Each					
MTBF		500,000				Hour

Typical Characteristics: $V_{out}=5V$

Input filter: N/A

Output filter: 100uF/16V*1 Electrolytic cap

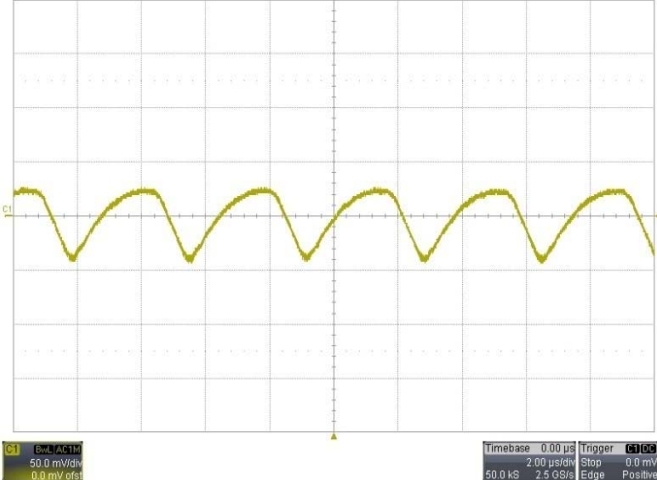

Noise $V_{IN}=40V$, $I_o=2A$, 5~20MHz Bandwidth

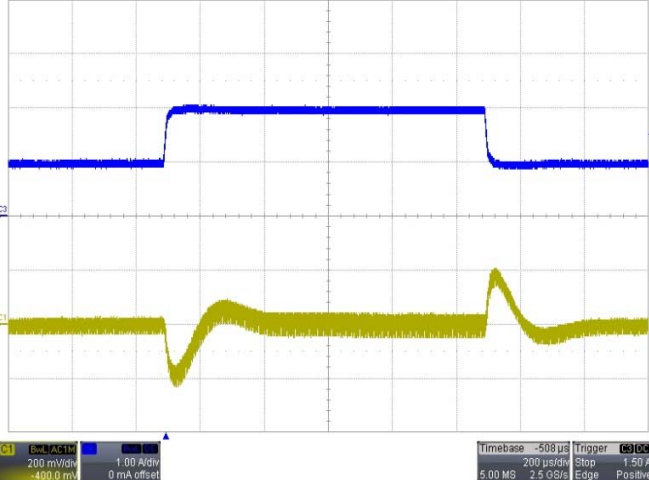

Transient Response, $V_{in}=40V$ $I_o=50\% \sim 100\% \sim 50\%$
(C1: Output Voltage, C3: Load current)

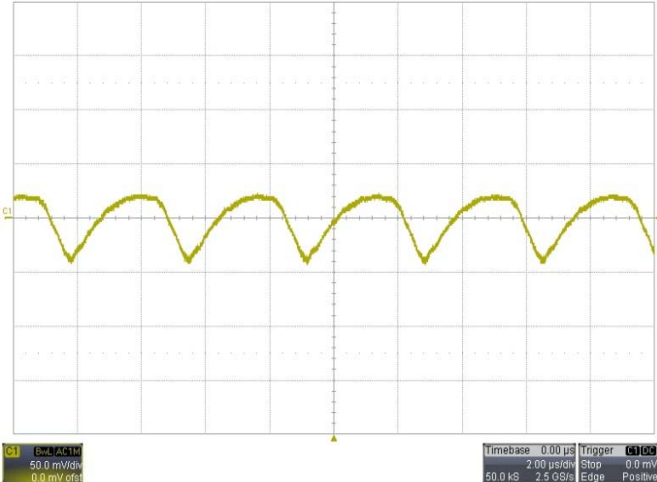

Noise $V_{IN}=48V$, $I_o=2A$, 5~20MHz Bandwidth

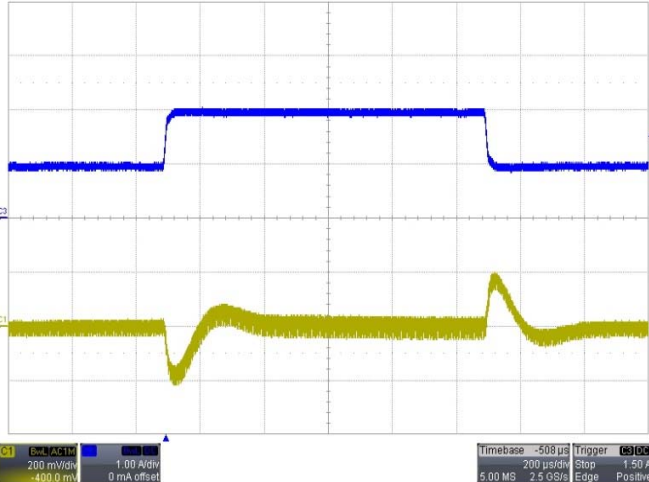

Transient Response, $V_{in}=48V$, $I_o=50\% \sim 100\% \sim 50\%$
(C1: Output Voltage, C3: Load current)

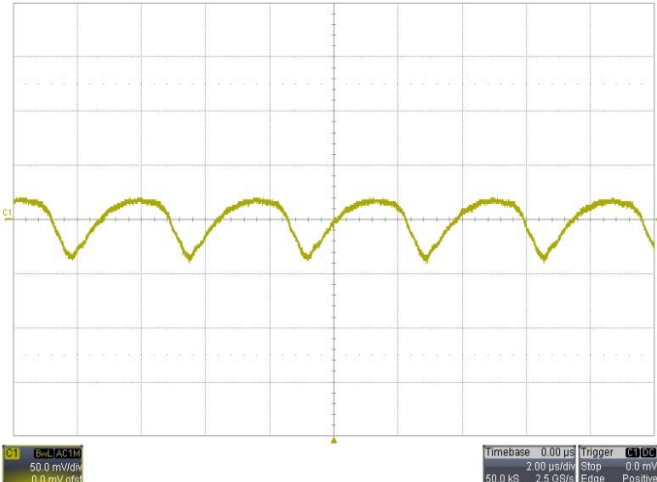

Noise $V_{IN}=57V$, $I_o=0.58A$, 5~20MHz Bandwidth

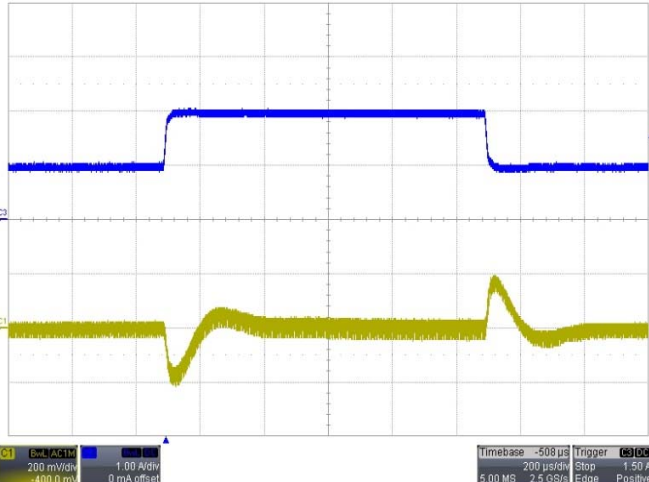

Transient Response $V_{IN}=57V$, $I_o=50\% \sim 100\% \sim 50\%$
(C1: Output Voltage, C3: Load current)

POE input power module MQ7813

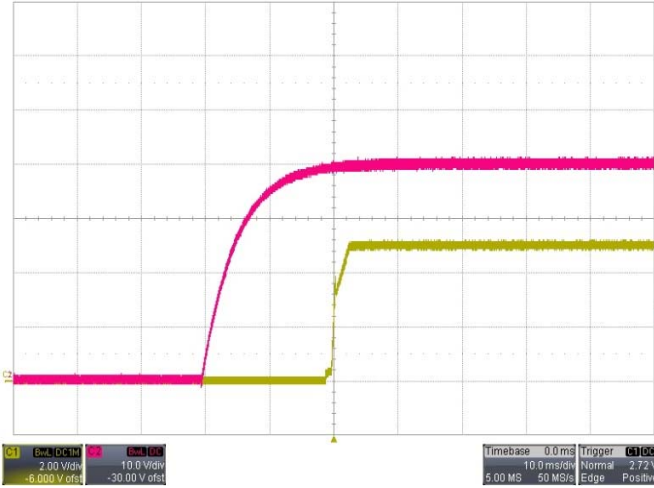

Power Up Vin=40V
(C1: output, C2: input)

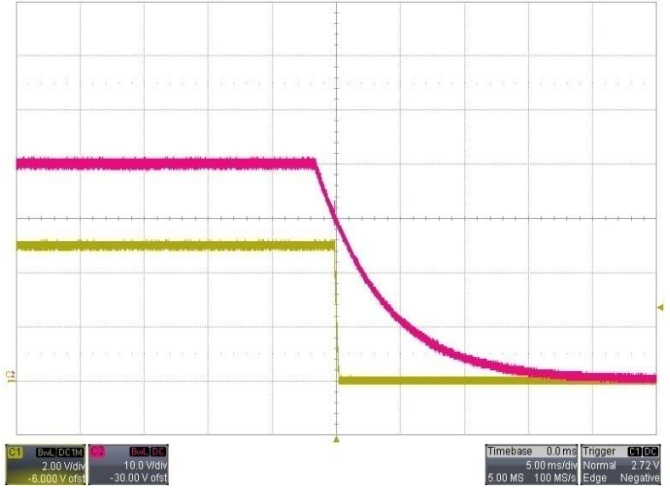

Power Down Vin=40V
(C1: output, C2: input)

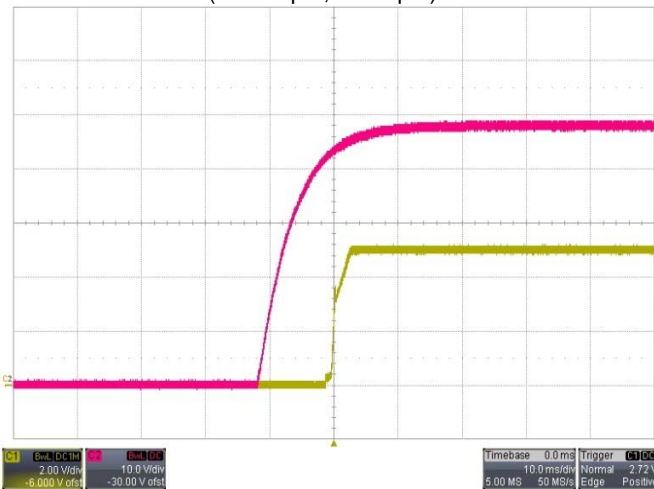

Power Up Vin=48V
(C1: output, C2: input)

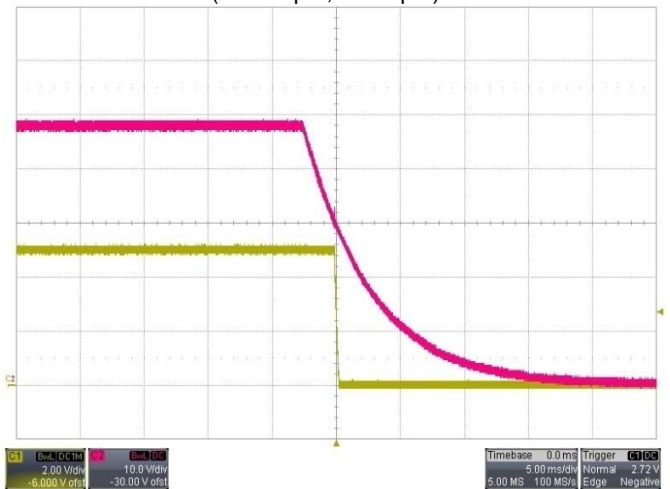

Power Down Vin=48V
(C1: output, C2: input)

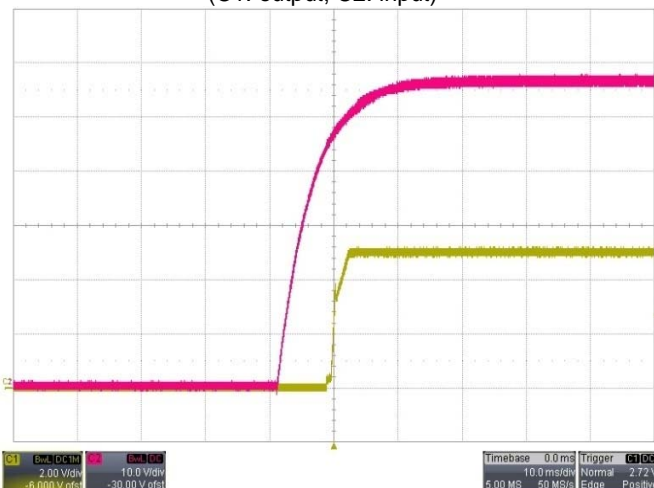

Power Up Vin=57V
(C1: output, C2: input)

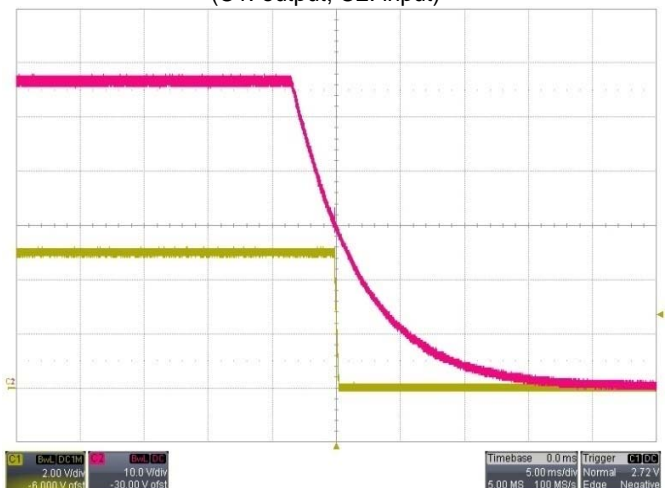

Power Down, Vin=57V
(C1: output, C2: input)

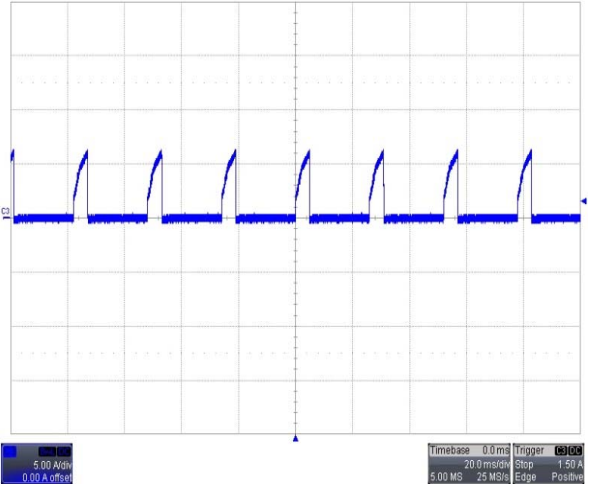

Short-Circuit Output, Vin=40V
(C3: Load current)

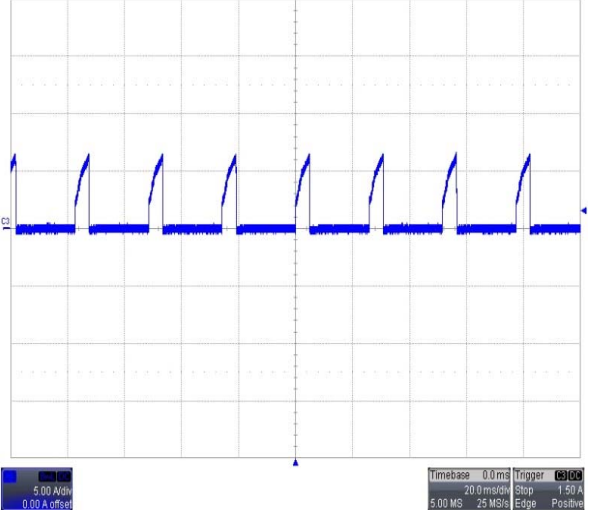

Short-Circuit Output, Vin=48V
(C3: Load current)

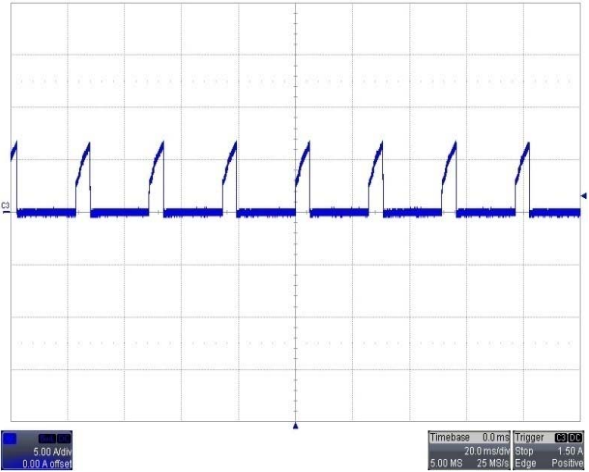

Short-Circuit Output Vin=57V
(C3: Load current)

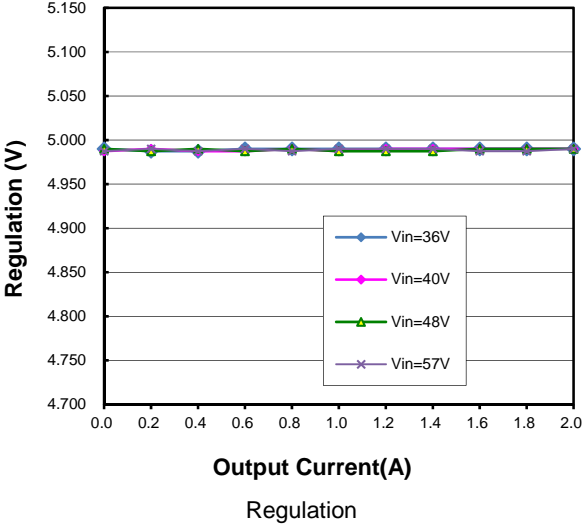
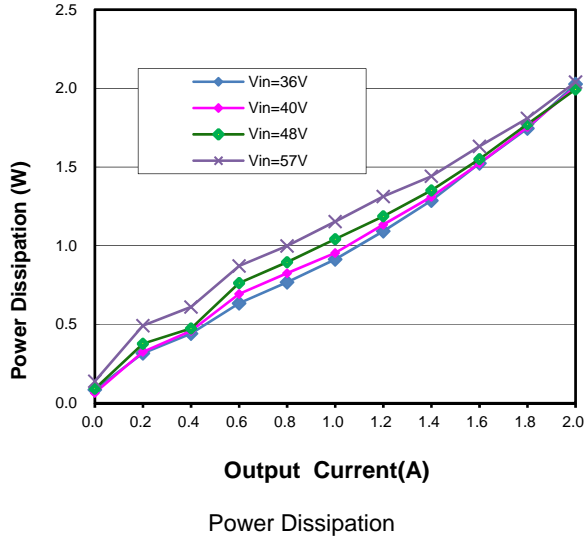
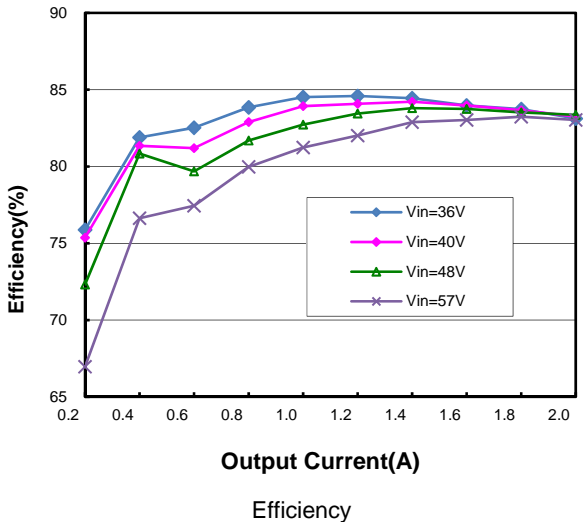

Typical Characteristics: $V_{out}=12V$

Input filter: N/A

Output filter: 68uF/25V*1 Electrolytic cap

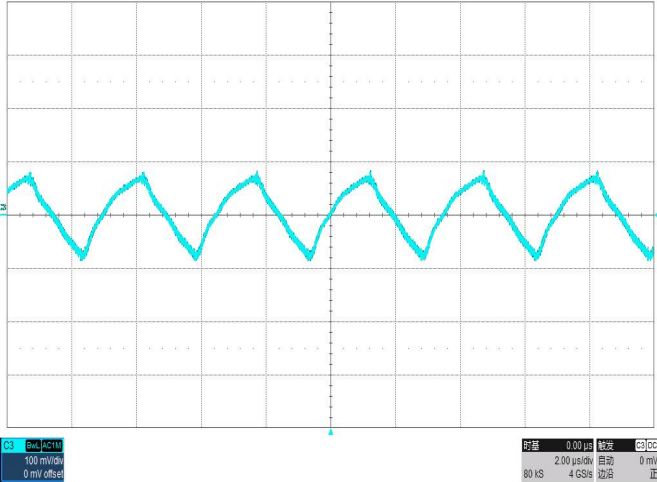

Noise $V_{IN}=36V, I_o=1A, 5\sim 20MHz$ Bandwidth

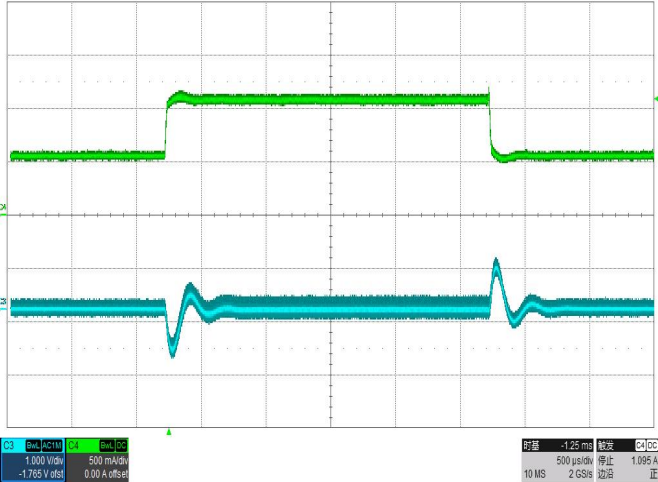

Transient Response, $V_{in}=36V, I_o=50\%\sim 100\%\sim 50\%$
(C3: Output Voltage, C4: Load current)

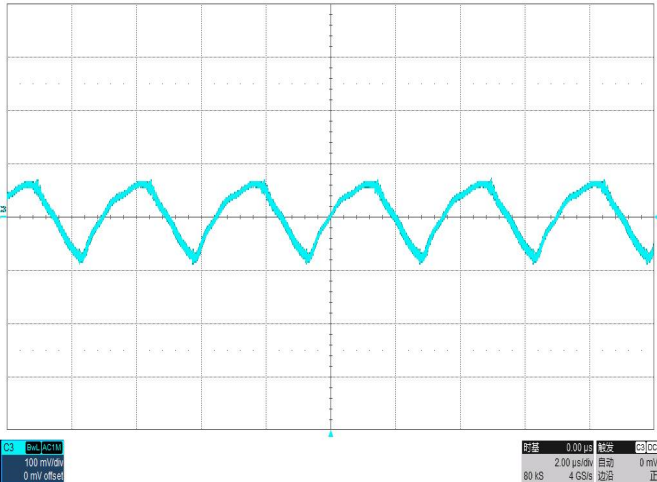

Noise $V_{IN}=48V, I_o=1.1A, 5\sim 20MHz$ Bandwidth

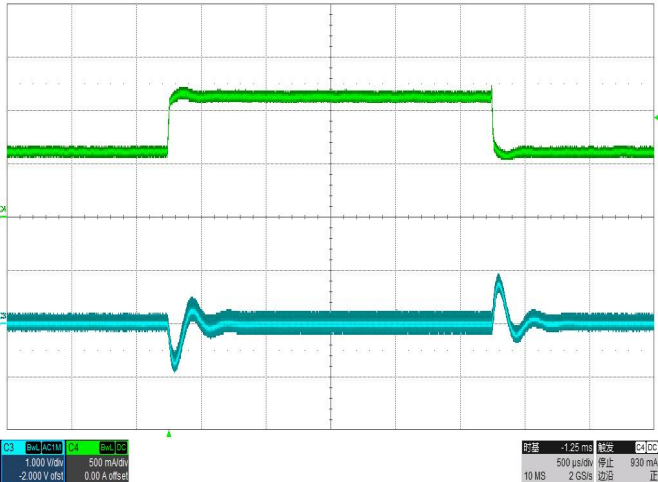

Transient Response, $V_{in}=48V, I_o=50\%\sim 100\%\sim 50\%$
(C3: Output Voltage, C4: Load current)

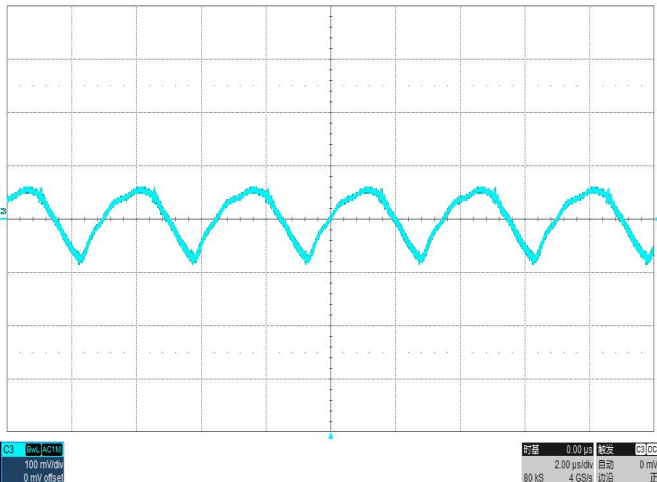

Noise $V_{IN}=57V, I_o=1.1A, 5\sim 20MHz$ Bandwidth

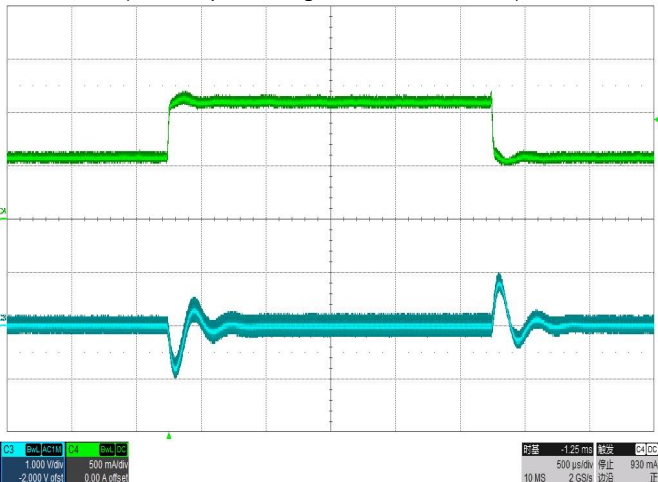

Transient Response $V_{IN}=57V, I_o=50\%\sim 100\%\sim 50\%$
(C3: Output Voltage, C4: Load current)

POE input power module MQ7813

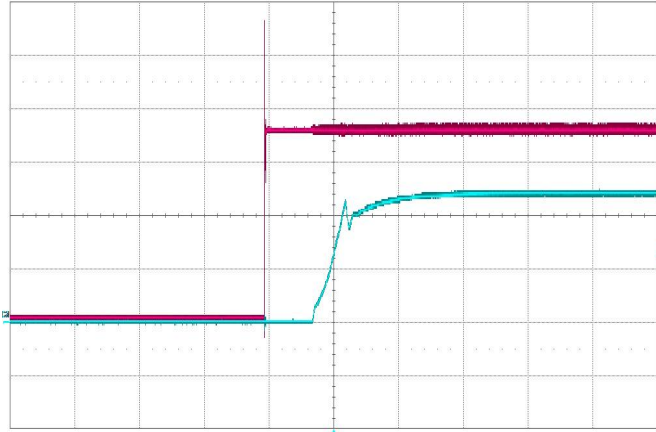

Power Up Vin=36V
(C3: output, C2: input)

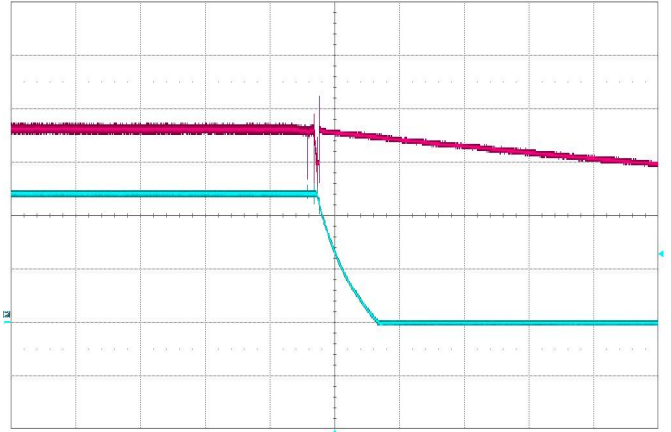

Power Down Vin=36V
(C3: output, C2: input)

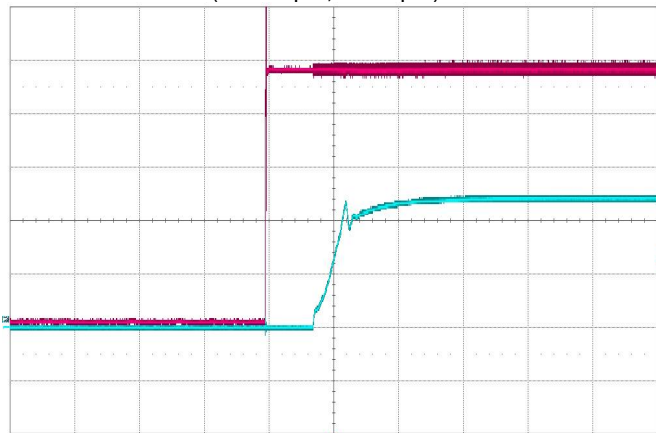

Power Up Vin=48V
(C3: output, C2: input)

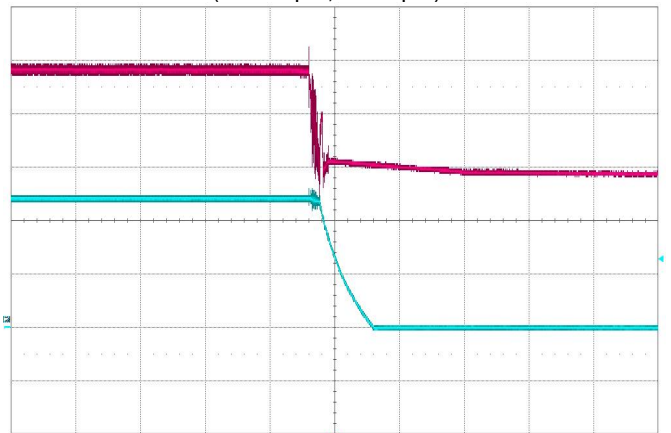

Power Down Vin=48V
(C3: output, C2: input)

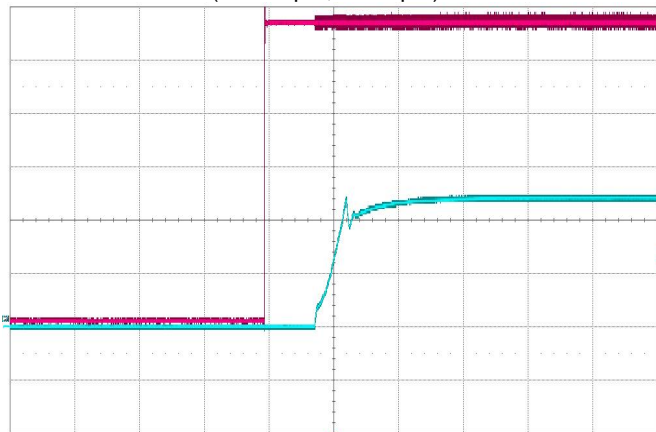

Power Up Vin=57V
(C3: output, C2: input)

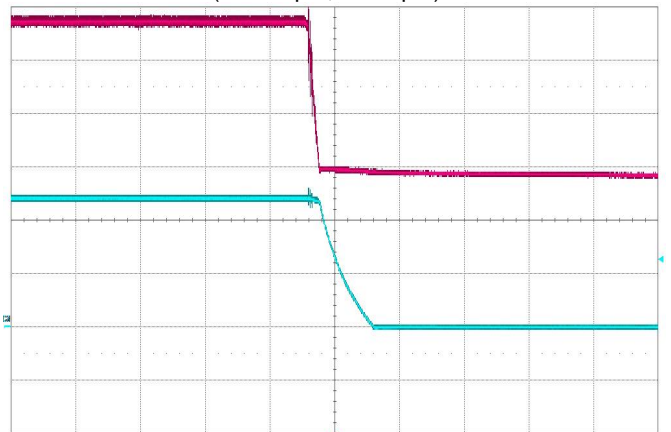

Power Down, Vin=57V
(C3: output, C2: input)

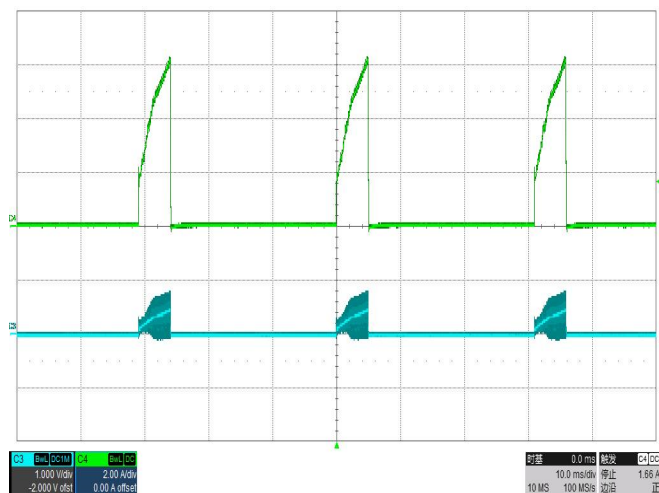

Short-Circuit Output, Vin=36V
(C4: Load current)

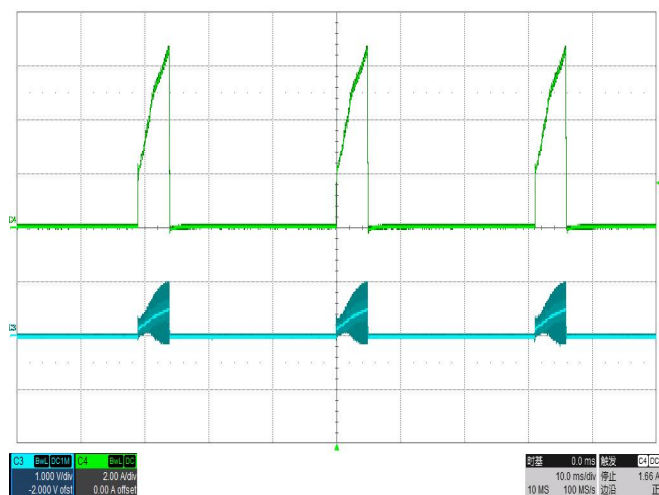

Short-Circuit Output, Vin=48V
(C4: Load current)

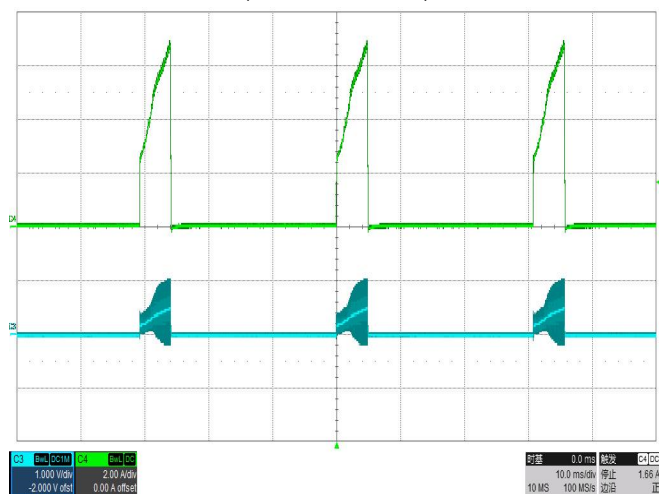

Short-Circuit Output Vin=57V
(C4: Load current)

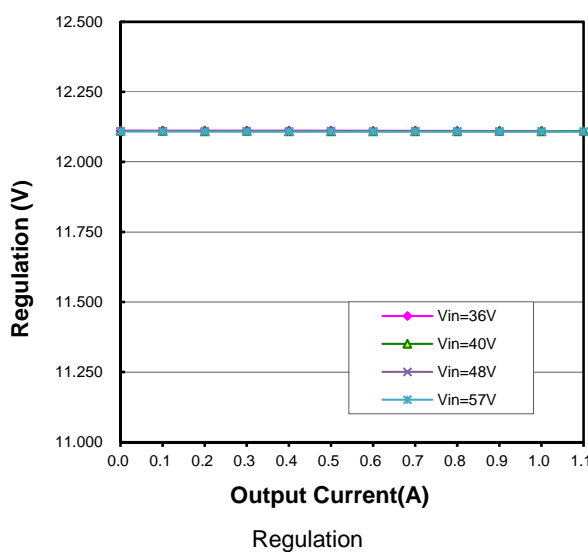
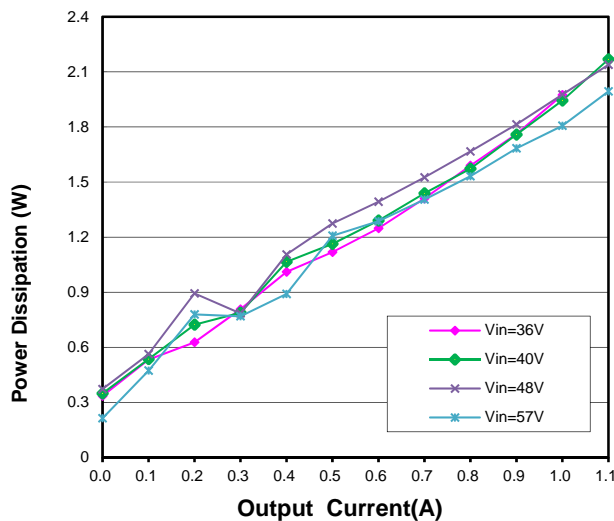
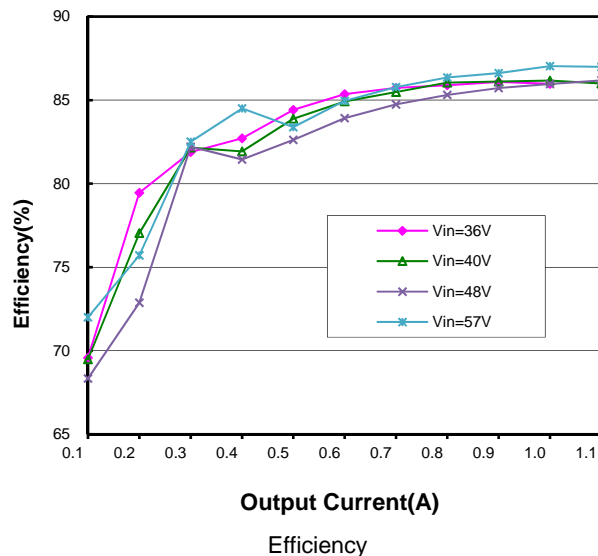

POE input power module MQ7813

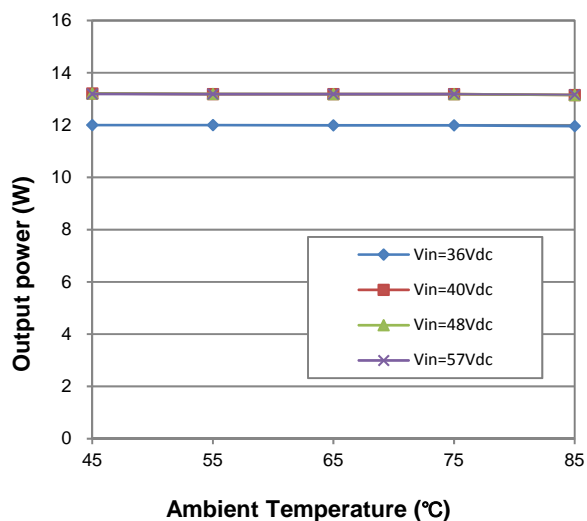

Ambient Temperature (°C)

Derating Curve

(Note: Output power is limited by PD IC internal over-current protection threshold, for 36V input, module only can load 1A.)

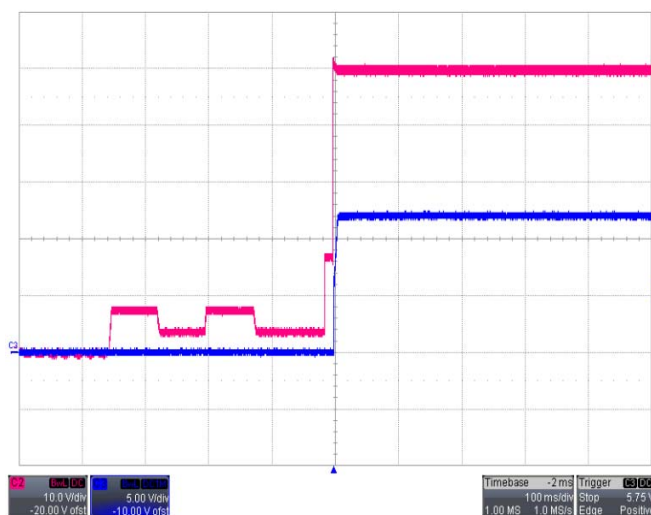

Startup with PSE

C1: MQ7813's output; C2: PSE's output

Recommended Hole Pattern

Dimensions are in millimeters[inches]

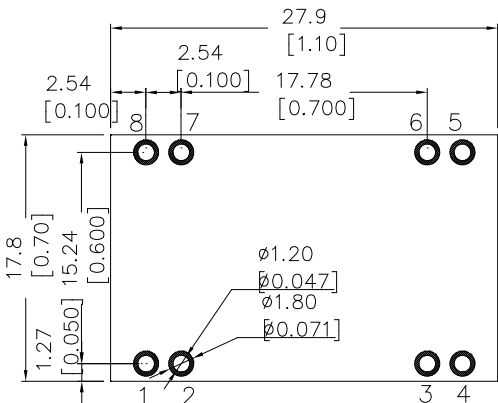

Component-side footprint

Recommended PAD Pattern for "S" package

Unit: millimeters[inches]

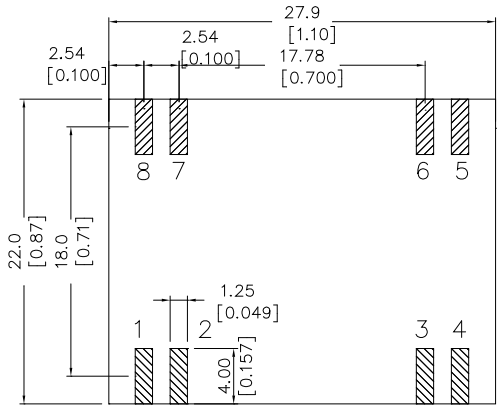

Component-side footprint