

LNTA4001NT1G

S-LNTA4001NT1G

Small Signal MOSFET

1. FEATURES

- Low Gate Charge for Fast Switching
- Small 1.6 X 1.6 mm Footprint
- ESD Protected Gate
- ESD Protected:2000V
- We declare that the material of product compliance with RoHS requirements and Halogen Free.
- S- prefix for automotive and other applications requiring unique site and control change requirements; AEC-Q101 qualified and PPAP capable.

2. APPLICATIONS

- Power Management Load Switch
- Level Shift
- Portable Applications such as Cell Phones, Media Players, Digital Cameras, PDA's, Video Games, Hand Held Computers, etc.

3. DEVICE MARKING AND RESISTOR VALUES

Device	Marking	Shipping
LNTA4001NT1G	TF	3000/Tape&Reel

4. MAXIMUM RATINGS(Ta = 25°C)

Parameter	Symbol	Limits	Unit
Drain-to-Source Voltage	VDSS	20	V
Gate-to-Source Voltage	VGS	±10	V
Continuous Drain Current (Note 1)	ID	238	mA
Power Dissipation (Note 1)	PD	300	mW
Pulsed Drain Current (tp ≤ 10 μs)	IDM	714	mA
Operating Junction and Storage Temperature	Tj, Tstg	-55~+150	°C
Continuous Source Current (Body Diode)	ISD	238	mA
Lead Temperature for Soldering Purposes (1/8" from case for 10 s)	TL	260	°C

5. THERMAL CHARACTERISTICS

Parameter	Symbol	Limits	Unit
Junction-to-Ambient – Steady State (Note 1)	RθJA	416	°C/W

1. Surface-mounted on FR4 board using 1 in sq pad size

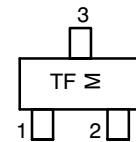
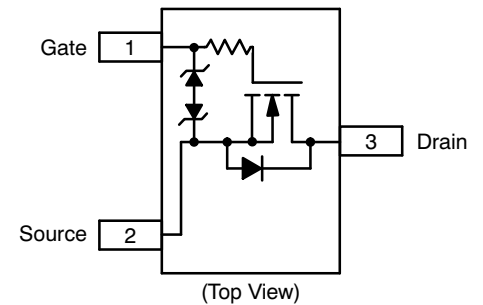
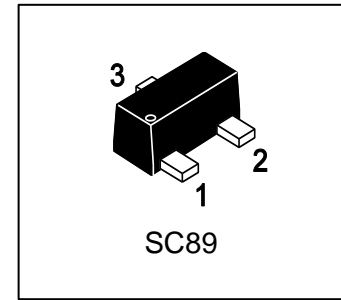

TF = Specific Device Code
M = Month Code

6. ELECTRICAL CHARACTERISTICS (Ta= 25°C)

Characteristic	Symbol	Min.	Typ.	Max.	Unit	
Drain–Source Breakdown Voltage (VGS = 0, ID = 100μA)	VBRDSS	20	-	-	V	
Zero Gate Voltage Drain Current (VGS = 0, VDS = 20 V)	IDSS	-	-	1	μA	
Gate–to–Source Leakage Current (VDS = 0 V, VGS = ±10 V)	IGSS	-	-	±100	μA	
Gate Threshold Voltage (VDS = 3 V, ID = 100μA)	VGS(th)	0.5	1	1.5	V	
Drain–to–Source On Resistance (VGS = 4.5 V, ID = 10 mA) (VGS = 2.5 V, ID = 10 mA)	RDS(on)	- -	1.5 2.2	3 3.5	Ω	
Input Capacitance (VDS = 5.0 V, f = 1 MHz, VGS = 0 V)	Ciss	-	11.5	20	pF	
Output Capacitance (VDS = 5.0 V, f = 1 MHz, VGS = 0 V)	Coss	-	10	15	pF	
Reverse Transfer Capacitance (VDS = 5.0 V, f = 1 MHz, VGS = 0 V)	Crss	-	3.5	6	pF	
Turn–On Delay Time	(VGS = 4.5 V, VDS = 5 V, ID = 10 mA, RG = 10 Ω)	td(ON)	-	13	-	ns
Rise Time		tr	-	15	-	
Turn–Off Delay Time		td(OFF)	-	98	-	
Fall Time		tf	-	60	-	
Diode Forward Voltage (VGS = 0 V, IS = 10 mA)	VSD	-	0.66	0.8	V	

2. Pulse Test: pulse width $\leq 300 \mu\text{s}$, duty cycle $\leq 2\%$.

3. Switching characteristics are independent of operating junction temperatures.

7. ELECTRICAL CHARACTERISTICS CURVES

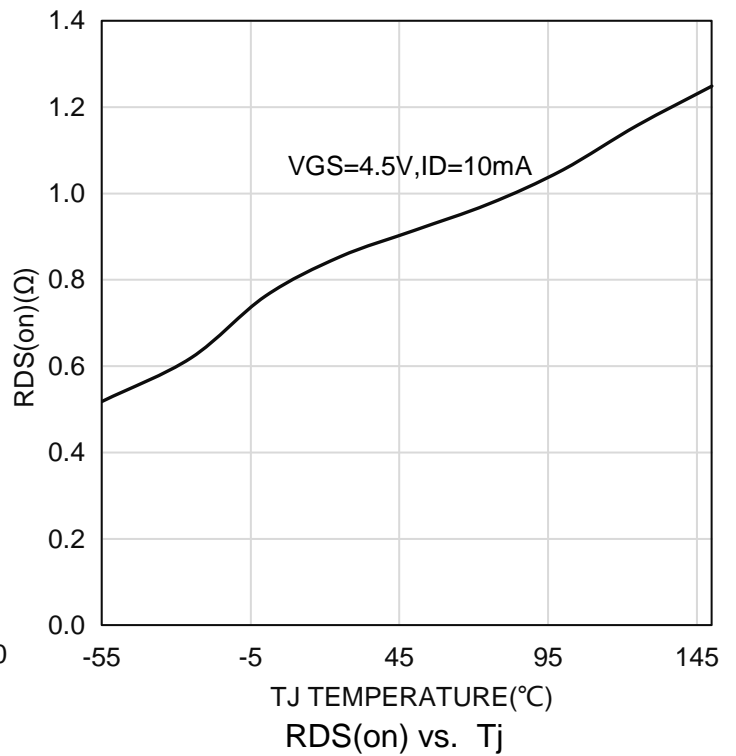
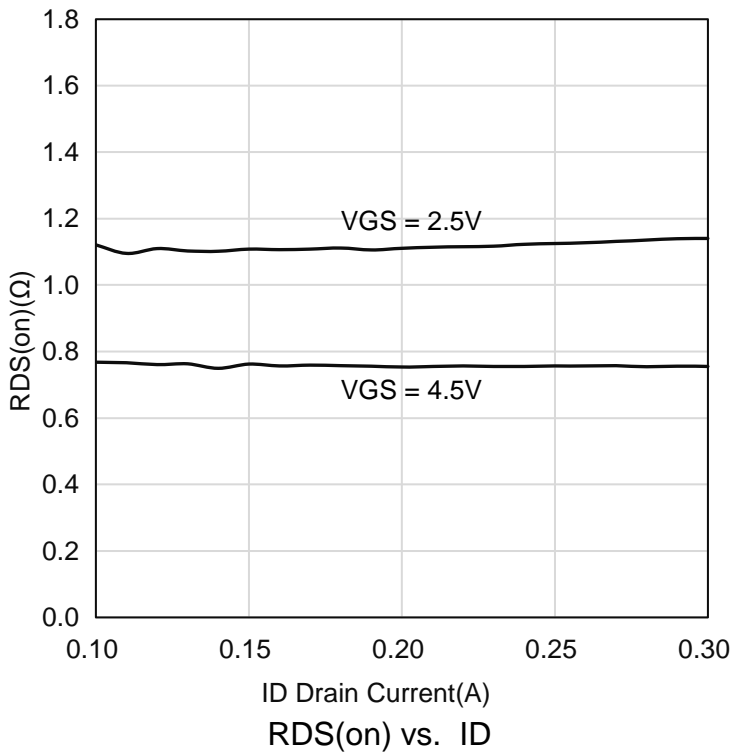
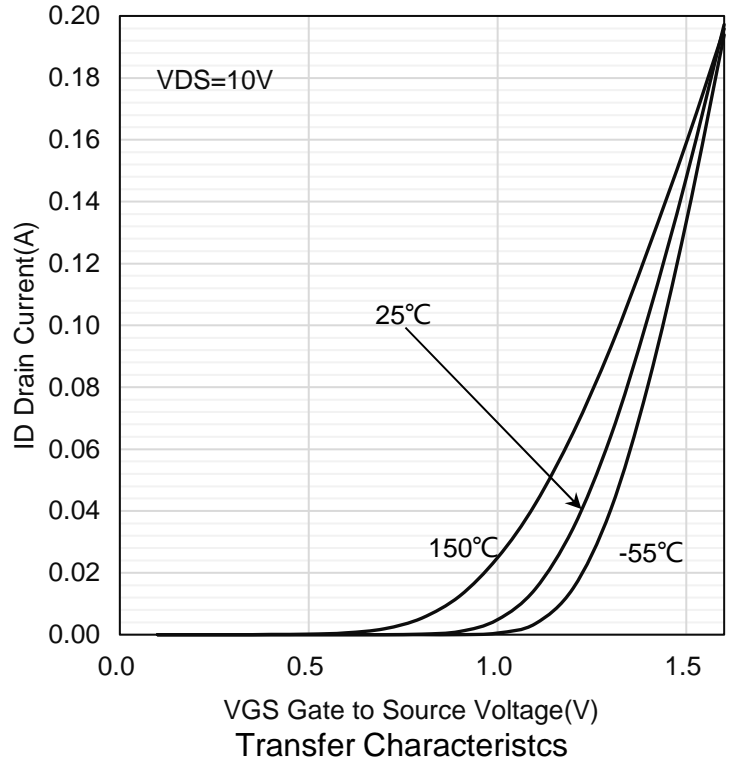
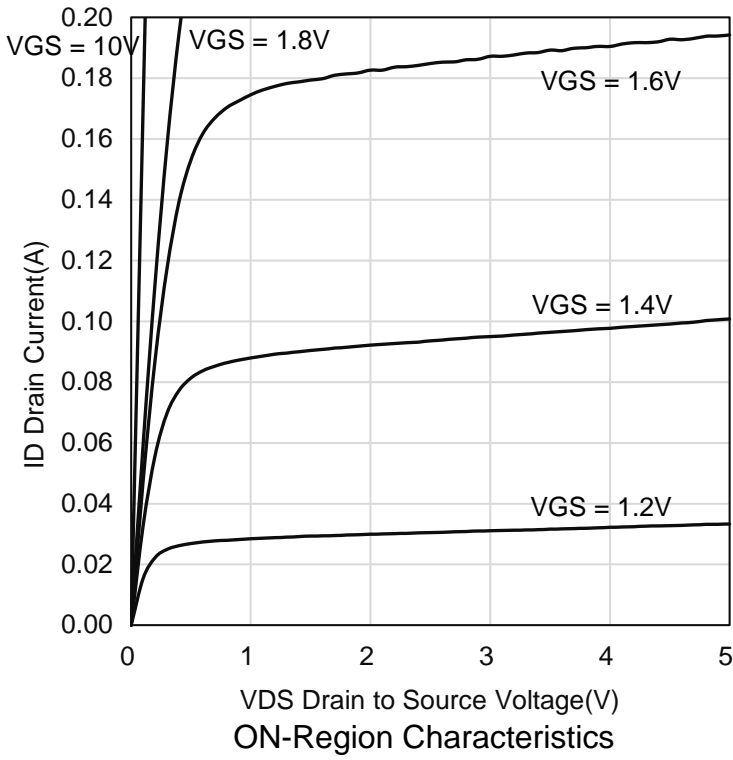

7.ELECTRICAL CHARACTERISTICS CURVES(Con.)

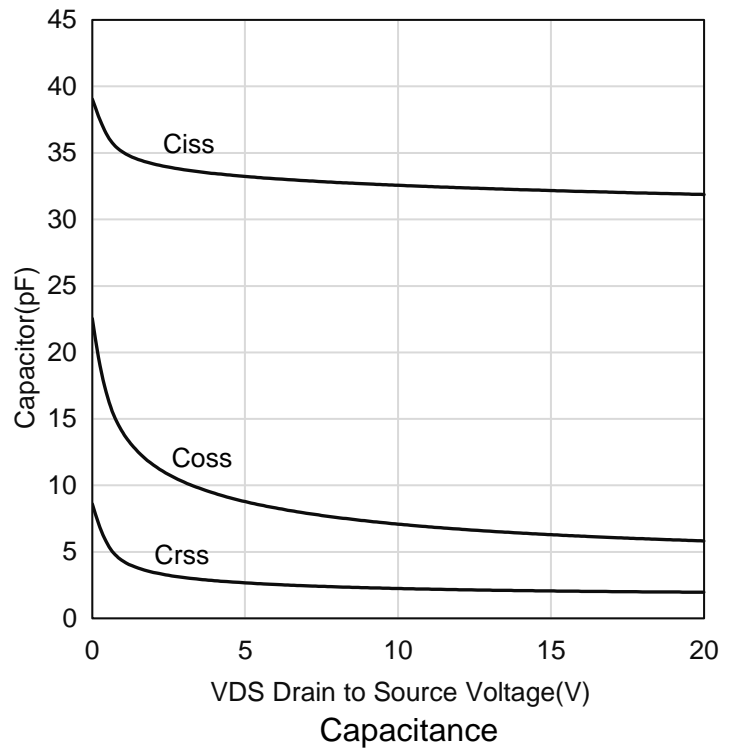
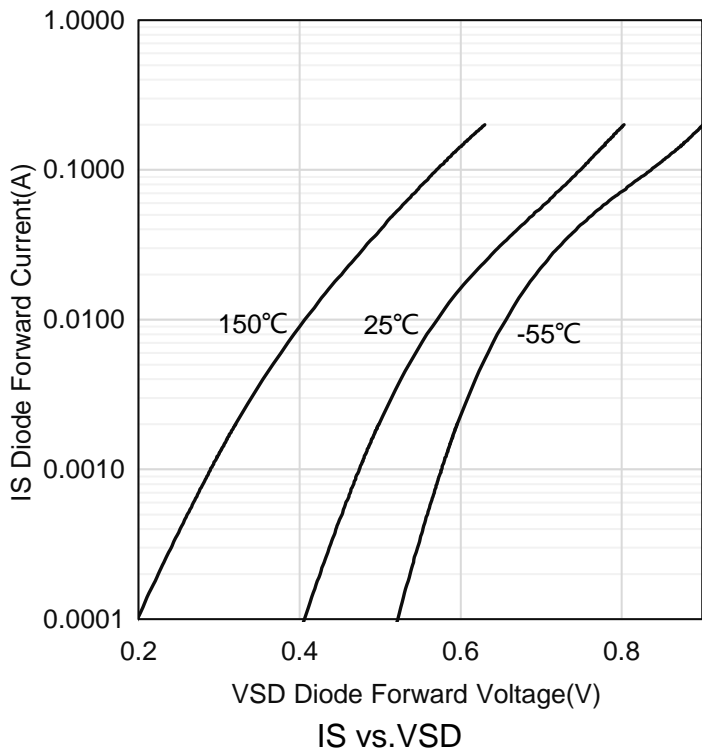
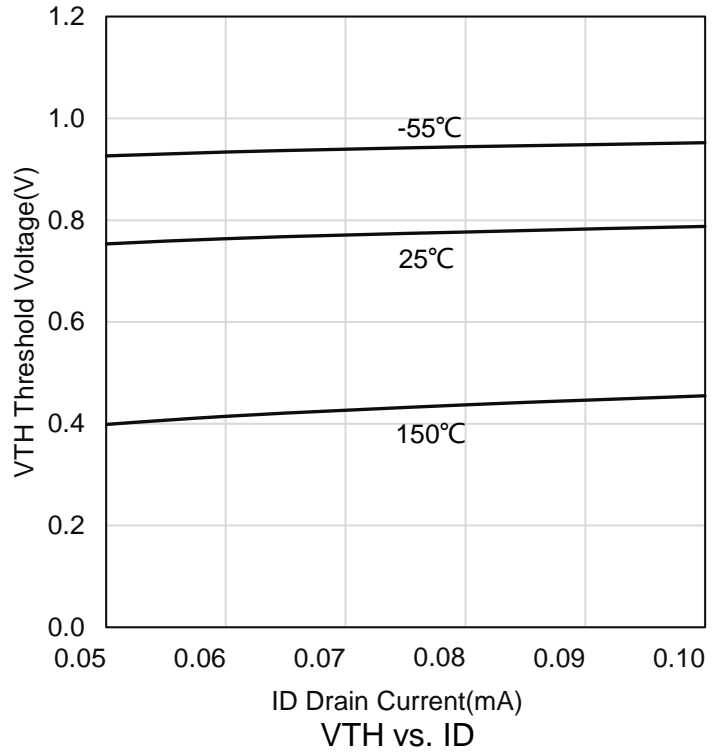
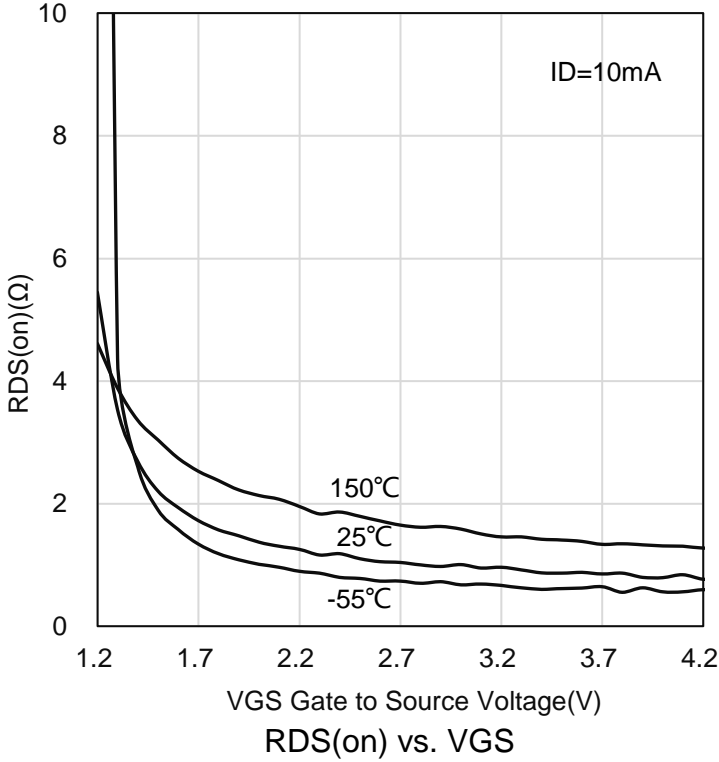

8.OUTLINE AND DIMENSIONS

Notes:

1. DIMENSIONING AND TOLERANCING PER ANSI Y14.5M, 1982.
2. CONTROLLING DIMENSION: MILLIMETERS.
3. MAXIMUM LEAD THICKNESS INCLUDES LEAD FINISH. MINIMUM LEAD THICKNESS IS THE MINIMUM THICKNESS OF BASE MATERIAL.
4. DIMENSIONS A AND B DO NOT INCLUDE MOLD FLASH, PROTRUSIONS OR GATE BURRS.

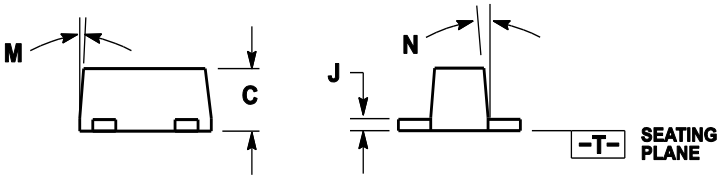
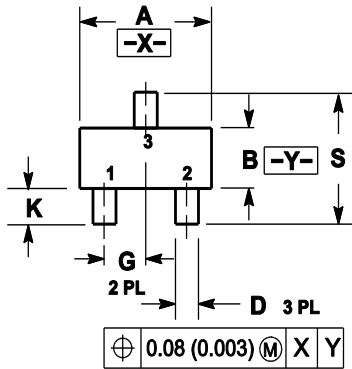

DIM	MILLIMETERS			INCHES		
	MIN	NOM	MAX	MIN	NOM	MAX
A	1.50	1.60	1.70	0.059	0.063	0.067
B	0.75	0.85	0.95	0.030	0.034	0.040
C	0.60	0.70	0.80	0.024	0.028	0.031
D	0.23	0.28	0.33	0.009	0.011	0.013
G	0.50BSC			0.020BSC		
H	0.53REF			0.021REF		
J	0.10	0.15	0.20	0.004	0.006	0.008
K	0.30	0.40	0.50	0.012	0.016	0.02
L	1.10REF			0.043REF		
M	---	---	10°	---	---	10°
N	---	---	10°	---	---	10°
S	1.50	1.60	1.70	0.059	0.063	0.067

9.SOLDERING FOOTPRINT

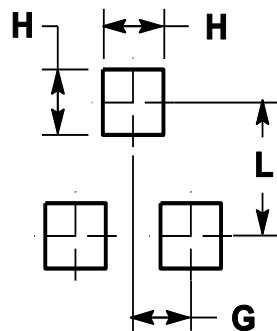

DISCLAIMER

- Before you use our Products, you are requested to carefully read this document and fully understand its contents. LRC shall not be in any way responsible or liable for failure, malfunction or accident arising from the use of any LRC's Products against warning, caution or note contained in this document.
- All information contained in this document is current as of the issuing date and subject to change without any prior notice. Before purchasing or using LRC's Products, please confirm the latest information with a LRC sales representative.