

LTVS8H4.5CBT5G

LTVS8H4.5CBT5G

Features

- Reverse stand-off voltage: $\pm 4.5V$ Max
- Low clamping voltage
- Complies with IEC 61000-4-2 standards:
 Air discharge: $\pm 30kV$
 Contact discharge: $\pm 30kV$
- RoHS Compliant
- MSL level :1

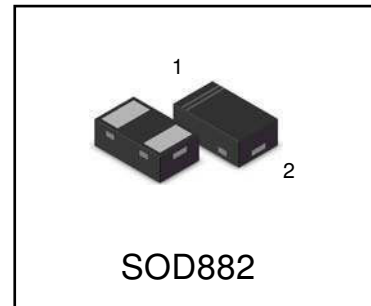

Ordering information

Device	Marking	Shipping
LTVS8H4.5CBT5G	B8	10000/Tape&Reel

Absolute Maximum Ratings ($T_A=25^{\circ}C$ unless otherwise specified)

Parameter	Symbol	Value	Unit
Peak Pulse Power (8/20 μ s)	Ppk	315	W
Peak Pulse Current (8/20 μ s)	I _{PP}	35	A
Operating Temperature Range	T _J	-55 to +125	$^{\circ}C$
Storage Temperature Range	T _{stg}	-55 to +150	$^{\circ}C$

LTVS8H4.5CBT5G

Electrical Characteristics

($T_A = 25^\circ\text{C}$ unless otherwise noted)

Symbol	Parameter
I_{PP}	Maximum Reverse Peak Pulse Current
V_C	Clamping Voltage @ I_{PP}
V_{RWM}	Reverse standoff voltage
I_R	Maximum Reverse Leakage Current @ V_{RWM}
V_{BR}	Breakdown Voltage @ I_T
I_T	Test Current
V_{TRIG}	Reverse trigger voltage
I_{TRIG}	Reverse trigger current

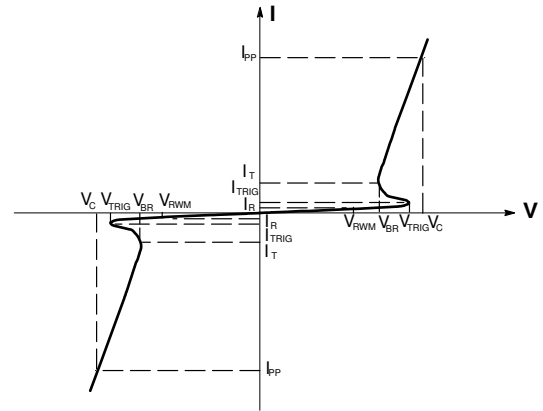

Bi-Directional TVS

Electrical Characteristics ($T_A=25^\circ\text{C}$ unless otherwise specified)

Parameter	Symbol	Min	Typ	Max	Unit	Test Condition
Reverse Working Voltage	V_{RWM}			4.5	V	
Breakdown Voltage	V_{BR}	4.8		6	V	$I_R = 1\text{ mA}$
Reverse Leakage Current	I_R			1	μA	$V_R = 4.5\text{V}$
Clamping Voltage	V_C			9	V	$I_{PP} = 35\text{A}$ (8 x 20 μs pulse)
Junction Capacitance	C_J		70		pF	$V_R = 0\text{V}$, $f = 1\text{MHz}$

LTVS8H4.5CBT5G

Typical Performance Characteristics ($T_A=25^{\circ}\text{C}$ unless otherwise Specified)

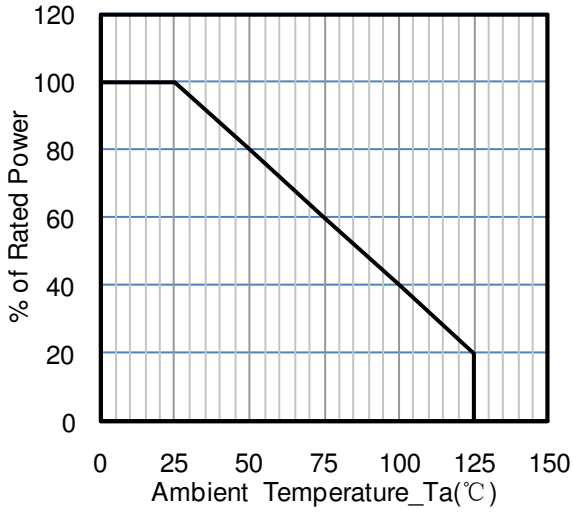

Fig1. Power Derating Curve

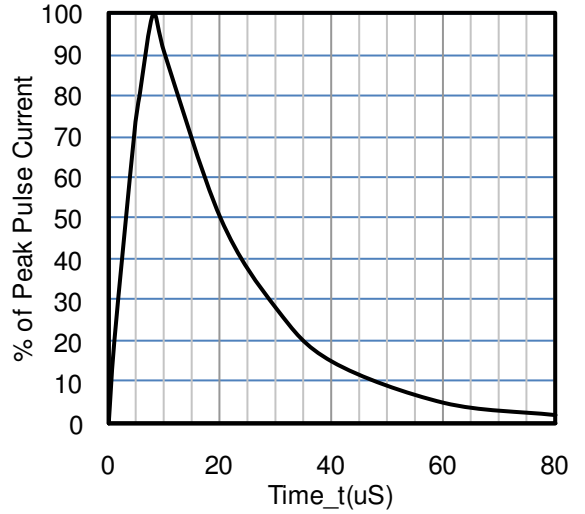

Fig2. 8 X 20uS Pulse Waveform

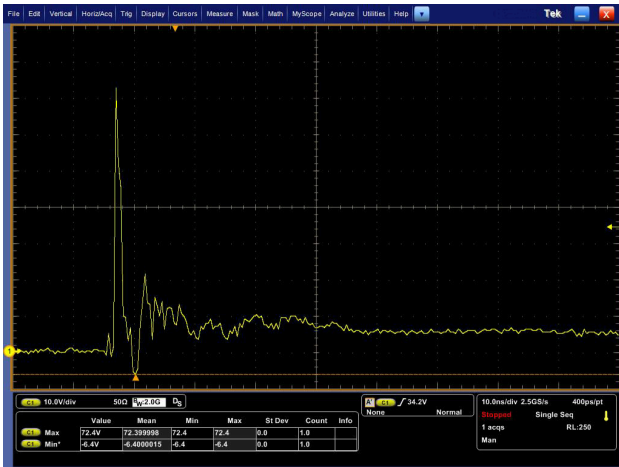

Figure 3. ESD Elamping Voltage Screenshot Positive 8 kV Eontact per IEE61000-4-2



Figure 4. ESD Elamping Voltage Screenshot Negative 8 kV Eontact per IEE61000-4-2

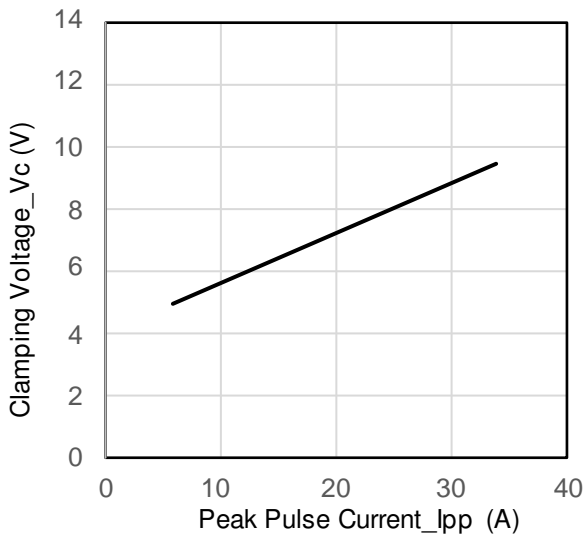
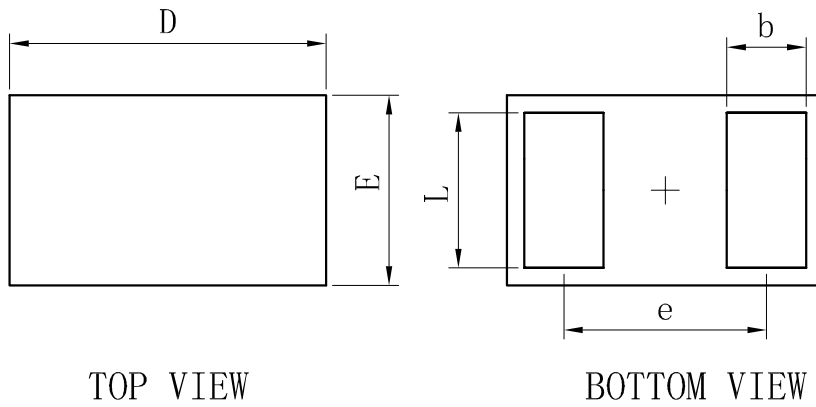

Figure 5. Clamping Voltage vs. Peak Pulse Current

LTVS8H4.5CBT5G

OUTLINE AND DIMENSIONS



SOD882			
Dim	Min	Typ	Max
D	0.95	1.00	1.05
E	0.55	0.60	0.65
e	-	0.64	-
L	0.44	0.49	0.54
b	0.20	0.25	0.30
A	0.43	0.48	0.53
A1	0	-	0.05
A3	0.127REF.		
All Dimensions in mm			

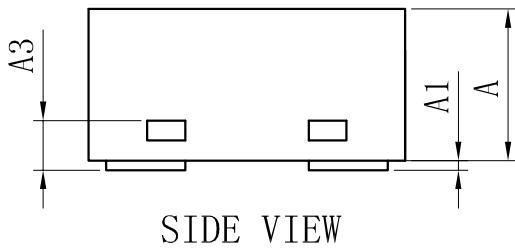

SOLDERING FOOTPRINT

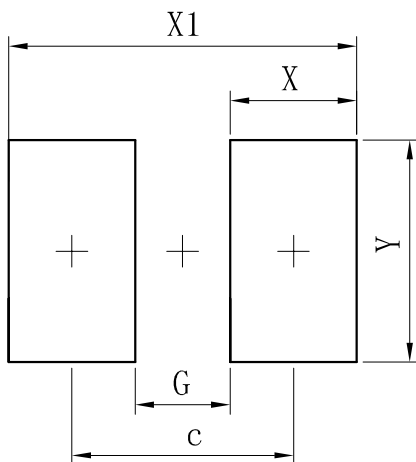

Dimensions	(mm)
c	0.70
G	0.30
X	0.40
X1	1.10
Y	0.70

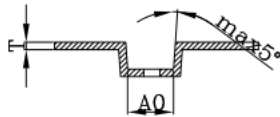
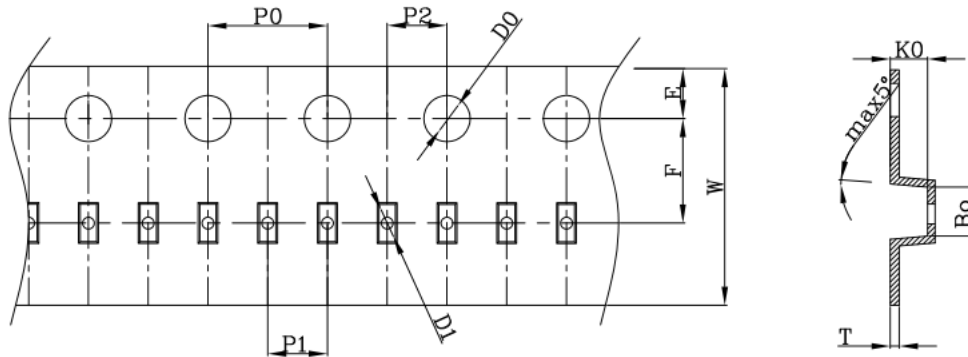
NOTE:

1. material: PC
2. 10 sprocket hole pitch cumulative tolerance ± 0.2 ;
3. camber not to exceed 1mm in 250mm;
4. All dimension should be met requirement of EIA-481-D;
5. Material must be met requirement of Rohs

SYMBOL	A0	B0	K0	P0	P1	P2
SPEC	0.69 \pm 0.05	1.19 \pm 0.05	0.63 \pm 0.05	4.00 \pm 0.05	2.00 \pm 0.05	2.00 \pm 0.05
SYMBOL	T	E	F	D0	D1	W
SPEC	0.2 \pm 0.02	1.75 \pm 0.1	3.50 \pm 0.05	1.55 \pm 0.05	0.4 \pm 0.1	8.00 \pm 0.1

TAPE AND REEL SPECIFICATIONS AND PACKAGING SPECIFICATIONS

Embossed Tape and Reel is used to facilitate automatic pick and place equipment feed requirements. The tape is used as the shipping container for various products and requires a minimum of handling. The antistatic/conductive tape provides a secure cavity for the product when sealed with the "peel - back" cover tape.

- . Two Reel Sizes Available (7" and 13")
- . Used for Automatic Pick and Place Feed Systems
- . Minimizes Product Handling
- . EIA 481, -1, -2
- . SOD - 123, SC - 59, SC - 70 / SOT - 323 , SC -70ML / SOT -363, SOT- 23, TSOP - 6, SOD - 323 SOD - 523 ,SOD-923,SOD-882 SOT- 723, SOT-883,SOD - 723 ,SC-89,SOT-1123,DFN0603 in 8 mm Tape
- . SOT - 223 in 12 mm Tape
- . SO - 14, SO -16 in 16 mm Tape

Use the standard device title and add the required suffix as listed in the option table on the following page. Note that the individual reels have a finite number of devices depending on the type of product contained in the tape. Also note the minimum lot size is one full reel for each line item, and orders are required to be in increments of the single reel quantity.

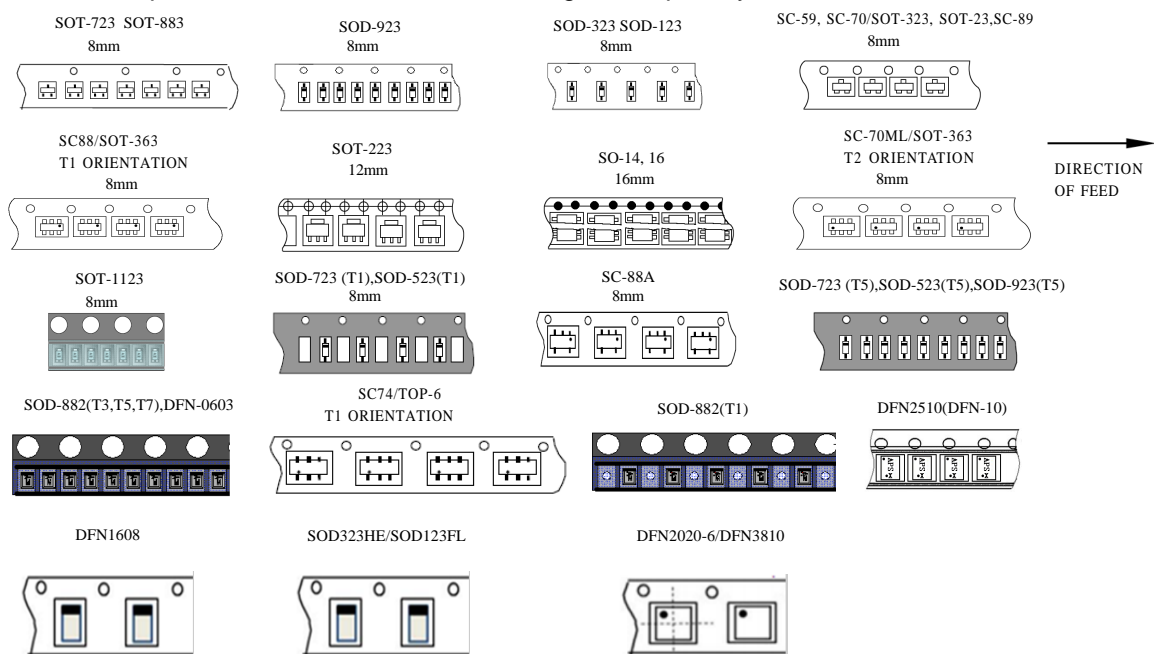

EMBOSSSED TAPE AND REEL ORDERING INFORMATION

Package	Tape Width (mm)	Pitch mm (inch)	Reel Size mm (inch)	Devices Per Reel and Minimum Order Quantity	Device Suffix
DFN-0603	8	2.0 ± 0.1 (.079 ± .004)	178 (7)	15,000	T1
SC-59	8	4.0 ± 0.1 (.157 ± .004)	178 (7)	3,000	T1
SC-70	8	4.0 ± 0.1 (.157 ± .004)	178 (7)	3,000	T1
SOT-323	8		330 (13)	10,000	T3
SO-14	16	8.0 ± 0.1 (.315 ± .004)	178 (7)	500	R1
	16		330 (13)	2,500	R2
SO-16	16	8.0 ± 0.1 (.315 ± .004)	178 (7)	500	R1
	16		330 (13)	2,500	R2
SOD-123	8	4.0 ± 0.1 (.157 ± .004)	178 (7)	3,000	T1
	8		330 (13)	10,000	T3
SOT-23 SC-89	8	4.0 ± 0.1 (.157 ± .004)	178 (7)	3,000	T1
	8		330 (13)	10,000	T3
SOT-223	12	8.0 ± 0.1 (.315 ± .004)	178 (7)	1,000	T1
	12		330 (13)	4,000	T3
SC-88A	8	4.0 ± 0.1 (.157 ± .004)	178 (7)	3,000	T1
SOT-363	8		178 (7)	10,000	T3
TSOP-6	8	4.0 ± 0.1 (.157 ± .004)	178 (7)	3,000	T1
SOD-323	8	4.0 ± 0.1 (.157 ± .004)	178 (7)	3,000	T1
SOD-923 SOT-1123	8	2.0 ± 0.1 (.079 ± .004)	178 (7)	8,000	T5
SOT-723 SOD-723	8	4.0 ± 0.1 (.157 ± .004)	178 (7)	4,000	T1
	8	2.0 ± 0.1 (.079 ± .004)	178 (7)	8,000	T5
SOD-882	8	4.0 ± 0.1 (.157 ± .004)	178 (7)	5,000	T1
SOT-883		2.0 ± 0.1 (.079 ± .004)		8,000	T3
		2.0 ± 0.1 (.079 ± .004)		10,000	T5
SOD-523	8	4.0 ± 0.1 (.157 ± .004)	178 (7)	3,000	T1
	8	2.0 ± 0.1 (.079 ± .004)	178 (7)	8,000	T5
DFN-2510 DFN-10	8	4.0 ± 0.1 (.157 ± .004)	178 (7)	3,000	T1
DFN1608	8	4.0 ± 0.1 (.157 ± .004)	178 (7)	10,000	T5
SOD323HE	8	4.0 ± 0.1 (.157 ± .004)	178 (7)	3,000	T1
SOD123FL	8	4.0 ± 0.1 (.157 ± .004)	178 (7)	3,000	T1
DFN2020-6S DFN3810	8	4.0 ± 0.1 (.157 ± .004)	178 (7)	4,000	T2
	12	4.0 ± 0.1 (.157 ± .004)	178 (7)	4,000	T2

EMBOSSED TAPE AND REEL DATA FOR DISCRETES CARRIER TAPE SPECIFICATIONS

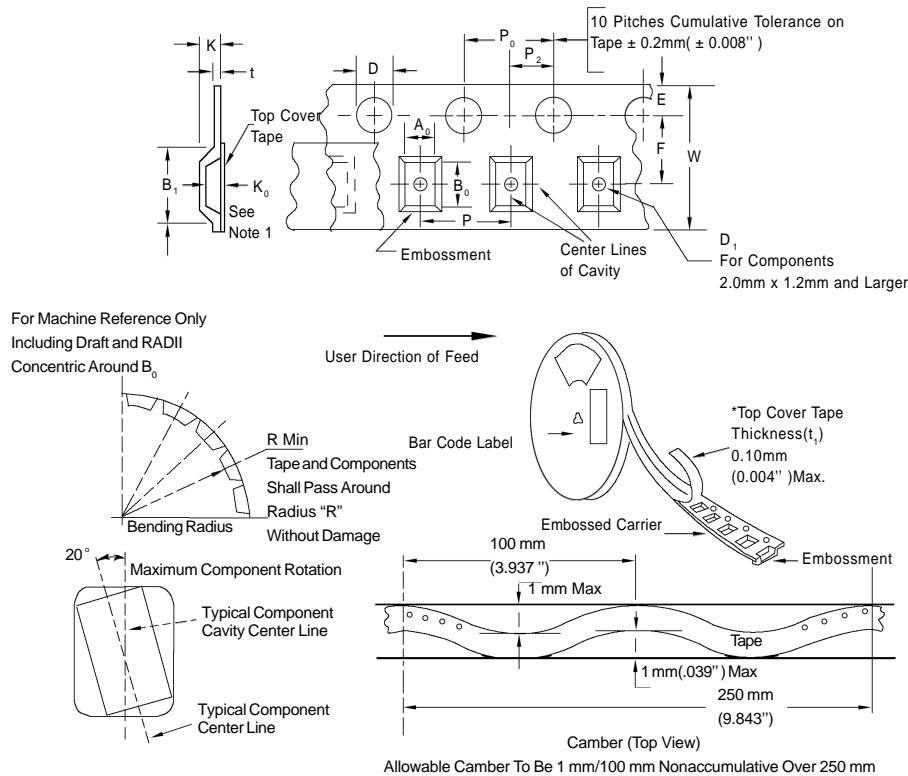

DIMENSIONS

Tape Size	B_1 Max	D	D_1	E	F	K	P_0	P_2	RMin	TMax	WMax
8mm	4.55mm (.179'')	1.5+0.1mm - 0.0	1.0Min (.039'')	1.75±0.1mm (.069±.004)	3.5±0.05mm (.138±.002'')	2.4mmMax (.094'')	4.0 ± 0.1mm (.157 ± .004'')	2.0 ± 0.1mm (.079 ± .002'')	25mm (.98'')	0.6mm (.024'')	8.3mm (.327'')
12mm	8.2mm (.323'')	(.059+.004'') -0.0	1.5mmMin (.060'')		5.5±0.05mm (.217±.002'')	6.4mmMax (.252'')			30mm (1.18'')		12 ± .30mm (.470 ± .012'')
16mm	12.1mm (.476'')				7.5±0.10mm (.295±.004'')	7.9mmMax (.311'')					16.3mm (.642'')
24mm	20.1mm (.791'')				11.5±0.1mm (.453±.004'')	11.9mmMax (.468'')					24.3mm (.957'')

Metric dimensions govern - English are in parentheses for reference only.

NOTE 1: A_0 , B_0 , and K_0 are determined by component size. The clearance between the components and the cavity must be within .05 mm min. to .50 mm max.,

NOTE 2: the component cannot rotate more than 10° within the determined cavity.

NOTE 3: If B_1 exceeds 4.2 mm (.165'') for 8 mm embossed tape, the tape may not feed through all tape feeders.

NOTE 4: Measure for 50+/-10 empty pockets at the tape leader using the ruler provided on the machine.

NOTE 5: At the end of counter units the handler will seal 110+/-10 empty pockets.

EMBOSSED TAPE AND REEL DATA FOR DISCRETES CARRIER TAPE SPECIFICATIONS

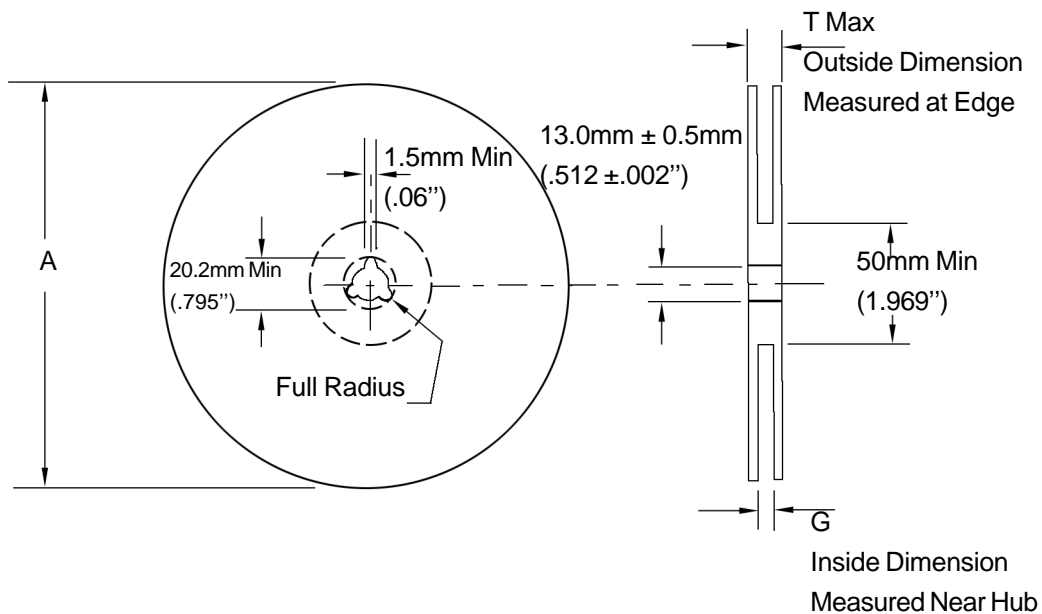

Size	A Max	G	T Max
8 mm	178.0mm (7.0")	8.4mm+1.5mm, -0.0 (.33"+.039", -0.00)	10.9mm (.43")
12 mm (SOP-8) (150Mil)	330.2mm (13.0")	12.4mm+0.2mm, -0.0 (.49"+.008", -0.00)	18.6mm (.73")

Reel Dimensions

Metric Dimensions Govern — English are in parentheses for reference only

Storage Conditions

Temperature: ≤ 35 Deg.C (20 to 30 Deg. C is preferred)

Humidity: ≤ 70 %RH (40 % to 60 % is preferred)

Recommended Period: Two years after manufacturing

(This recommended period is for the soldering condition only. The characteristics and reliabilities of the products are not restricted to this limitation)

Shipment Specification

