

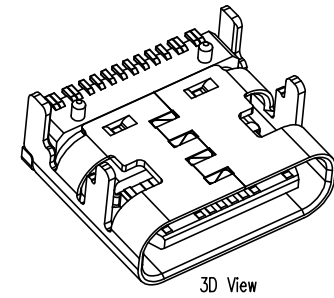

REV.	ECN NO OR DESCRIPTION	REVISED	DATE

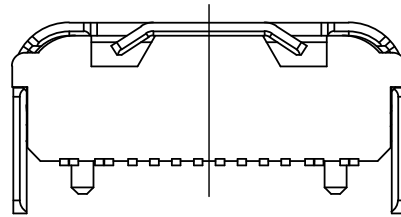
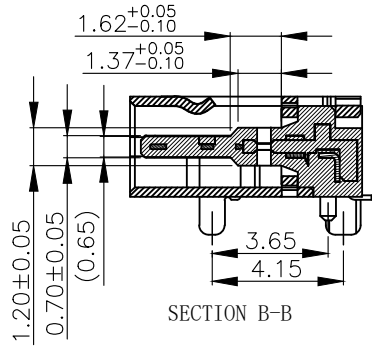
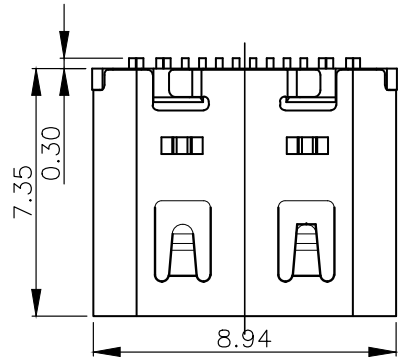

**SPECIFICATION:**

- Material:**  
HOUSING&MOLDING:LCP,UL94 V-0  
CONTACTS:COPPER ALLOY T=0.20mm  
MIDDLE CLIP:SUS301-1/2H,T=0.15mm  
SHELL:SUS, T=0.30mm
- Mechanical:**  
2.1.Mating force:5~20Nf Max.;  
2.2.Unmating force:6~20Nf Min.;  
2.3.Durability:10000 Cycles;
- Electrical:**  
3.1.Current Rating:3A Max.;  
3.2.Voltage Rating:20V Max.;  
3.3.Dielectric Withstanding voltage:100VAC;  
3.4.Contact resistance:40m Ohms Max.;  
3.5.Insulation Resistance:100M Ohms Min.;
- Environmental:**  
4.1.Operating temperature:-40°C~+85°C;  
4.2.Wetting Temperature:265±5°C,5±0.5s

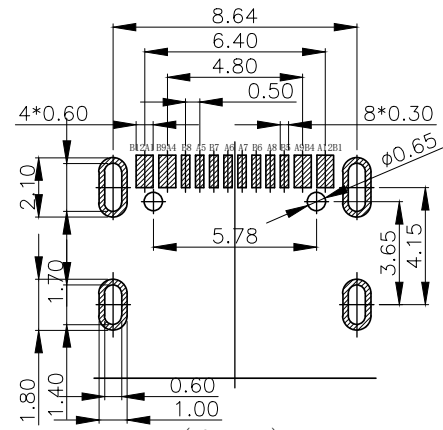
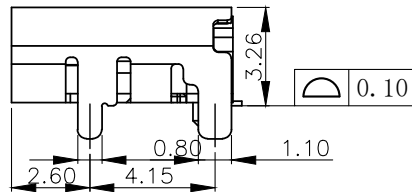
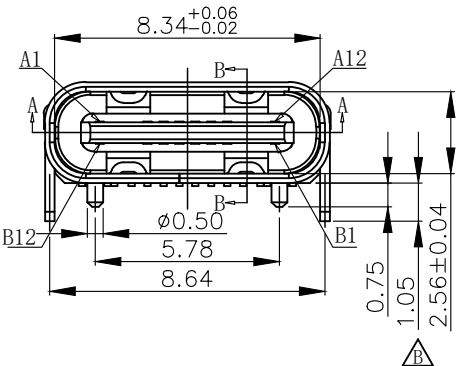

(TOP VIEW)  
RECOMMENDED P.C.B. LAYOUT (T:1.0~1.2mm)  
TOLERANCE UNSPECIFIED ±0.05mm

PIN ASSIGNMENT											
A1	A2	A3	A4	A5	A6	A7	A8	A9	A10	A11	A12
GND			VBUS	CC1	D+	D-	SBU1	VBUS			GND
GND			VBUS	SBU2	D-	D+	CC2	VBUS			GND
B12	B11	B10	B9	B8	B7	B6	B5	B4	B3	B2	B1

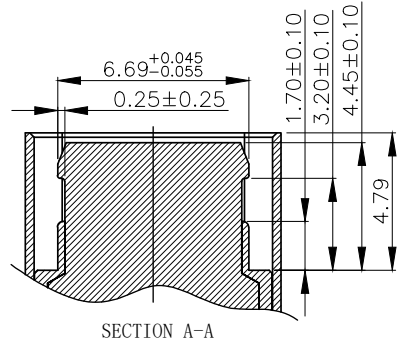
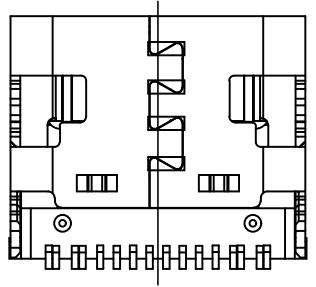

UNLESS OTHERWISE SPECIFIED TOLERANCES		东莞市汉博电子科技有限公司 DONGGUAN HANBO TECHNOLOGY CO., LTD	
DECIMALS:	ANGLES:	TITLE TYPE-C 16Pin 板上型 带双压片 7.35mm	
X :±0.50	.X° :±3.0°	DWN	xiong PART NO. MC-107DM
.X :±0.35	.XX° :±2.5°	CHKD	lee SCALE:1:1 UNIT: mm
.XX :±0.25	.XXX° :±2.0°	APVD	wang SIZE: A4 SHEET:10F 1
.XXX :±0.15			REV: A4
CUSTOMER COPY			



REV.	ECN NO OR DESCRIPTION	REVISED	DATE

说明:

1. 每卷前后各空16PCS, 尾部用美纹胶纸封住;
2. 将产品放满盘后, 再卷一圈保护带, 用美纹胶纸将其封住, 并贴上1Pcs物料标签;
3. 每10卷盘一叠共10000Pcs并装入1个外箱内;
4. 在搬运过程中要轻拿轻放;
5. 在运输中不可堆放过多(1.8M最高), 不可重压;
6. 跌落测试条件:  
成品箱从1.2米高度自由落体(一角三棱六面):  
a. 产品不可跑出下带凹槽;  
b. 产品不可有摔伤, 变形;  
c. 内包装材料不可严重破损.

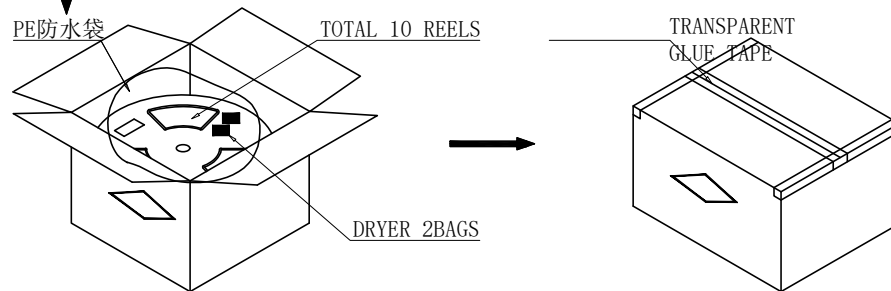
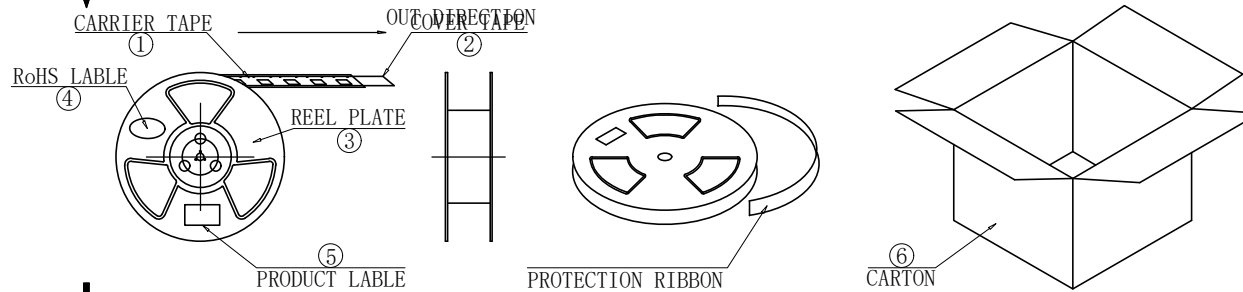
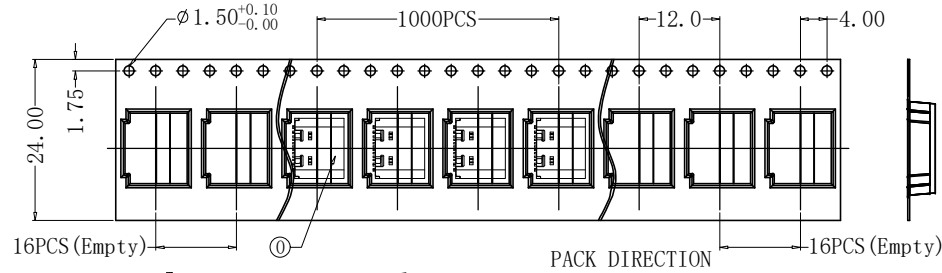

NO.	NAME	SPEC	Q' TY
①	TYPE C RECEPTACLE		10000PCS/CARTON
②	CARRIER TAPE	W=24mm, T=0.35mm	1000PCS/PLATE
③	COVER TAPE	W=21.5mm	10PLATES/CARTON
④	REEL PLATE	330*100*24.4mm	10PCS/CARTON
⑤	RoHS LABEL		10PCS/CARTON
⑥	PRODUCT LABELER		10PCS/CARTON
⑦	CARTON	350*340*310mm	1PCS/PACKAGE

UNLESS OTHERWISE SPECIFIED TOLERANCES

DECIMALS:	ANGLES:
X :±0.50	.X° :±3.0°
.X :±0.35	.XX° :±2.5°
.XX :±0.25	.XXX° :±2.0°
.XXX :±0.15	



东莞市汉博电子科技有限公司  
DONGGUAN HANBO TECHNOLOGY CO., LTD

TITLE	TYPE-C 16Pin板上型 带双压片 7.35mm-包装图			
DWN	xiong	PART NO. MC-107DM		
CHKD	lee	SCALE:1:1	UNIT: mm	④ ←
APVD	wang	SIZE: A4	SHEET:10F 1	REV: A4

CUSTOMER COPY