

REV.	ECN NO.	DATE	SIGN	DESCRIPTION
B	LEN1360021	2013/05/29	Sam	Modify Dimension.
C	LEN1560405	2015/05/25	Ruru	Change Logo

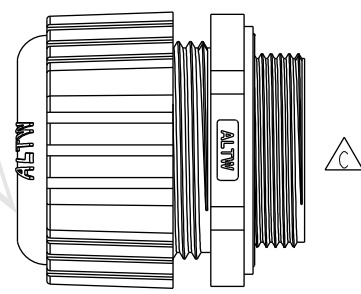
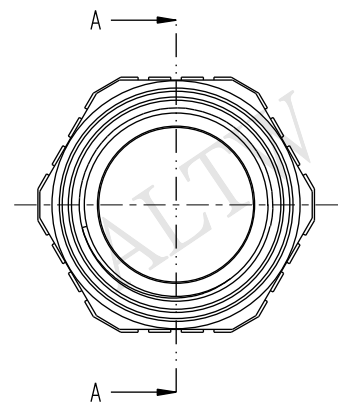
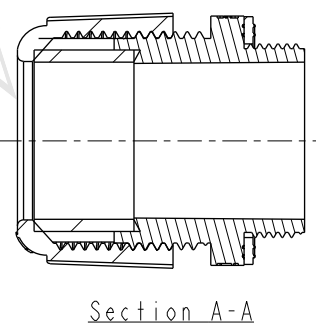
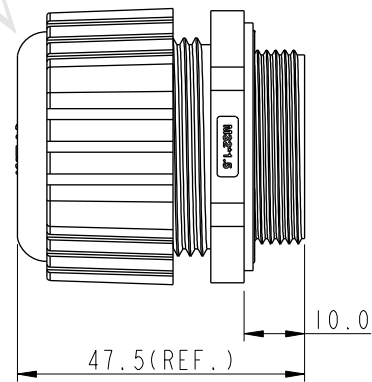
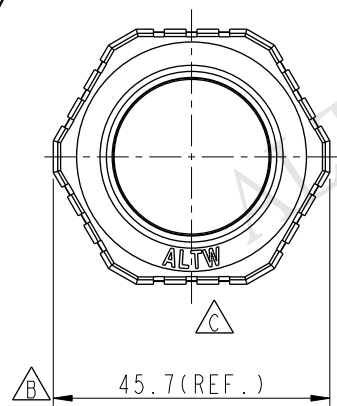
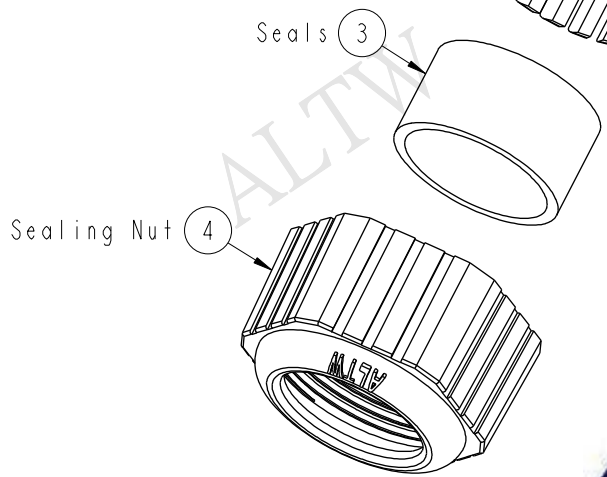
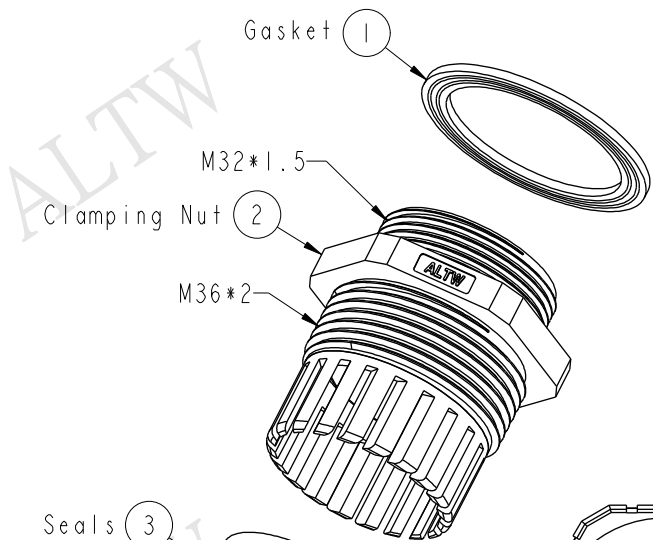

ALTW
 CONFIDENTIAL
 2015-05-25
 R&D DEPT.

ALTW
 DCC. DEPT.
 CONFIDENTIAL
 2015.07.06
 ISSUED

Note:

- * Waterproof Rate: IP68
- * Clamp Ring: Nylon, Gray
- * Sealing Nut: Nylon, Gray
- * Gasket: EPDM, Black
- * Seals: EPDM, Black
- * Cable Range: $\varnothing 18 \sim \varnothing 25 \text{mm}$
- * Spanner Size:
 Body: 41.0mm
 Sealing Nut: 42.2mm

UNIT: mm		TITLE Cable Gland Assembly(M32*1.5 - Short Type)
TOLERANCE .X ±0.25 .XX ±0.1 .XXX ±0.05 ANGLES ±1°	SCALE 4:5	SIZE A4
	REV. C	SHEET 1 OF 1
	WC-REV. A.1	QC: Inspection item

Amphenol LTW
 安費諾亮泰企業股份有限公司

ITEM NO CSG-32M008	DRAWN BY Ruru	DATE 2015-05-25
DWG NO CSG-32M008	CHECKED BY Rita	DATE 2015-05-25
CUSTOMER ALTW	APPROVED BY Lion	DATE 2015-05-25

THIS DOCUMENT IS SUBJECT TO CHANGE WITHOUT NOTICE. IT IS CONFIDENTIAL AND A PROPERTY OF AMPHENOL LTW. DISCLOSURE TO THIRD PARTY HAS TO BE AUTHORIZED BY AMPHENOL LTW.